

**SUBMERSIBLE
ELECTRIC PUMPS
FOR SOLIDLADEN
WASTEWATER
AND INDUSTRIAL
APPLICATIONS**

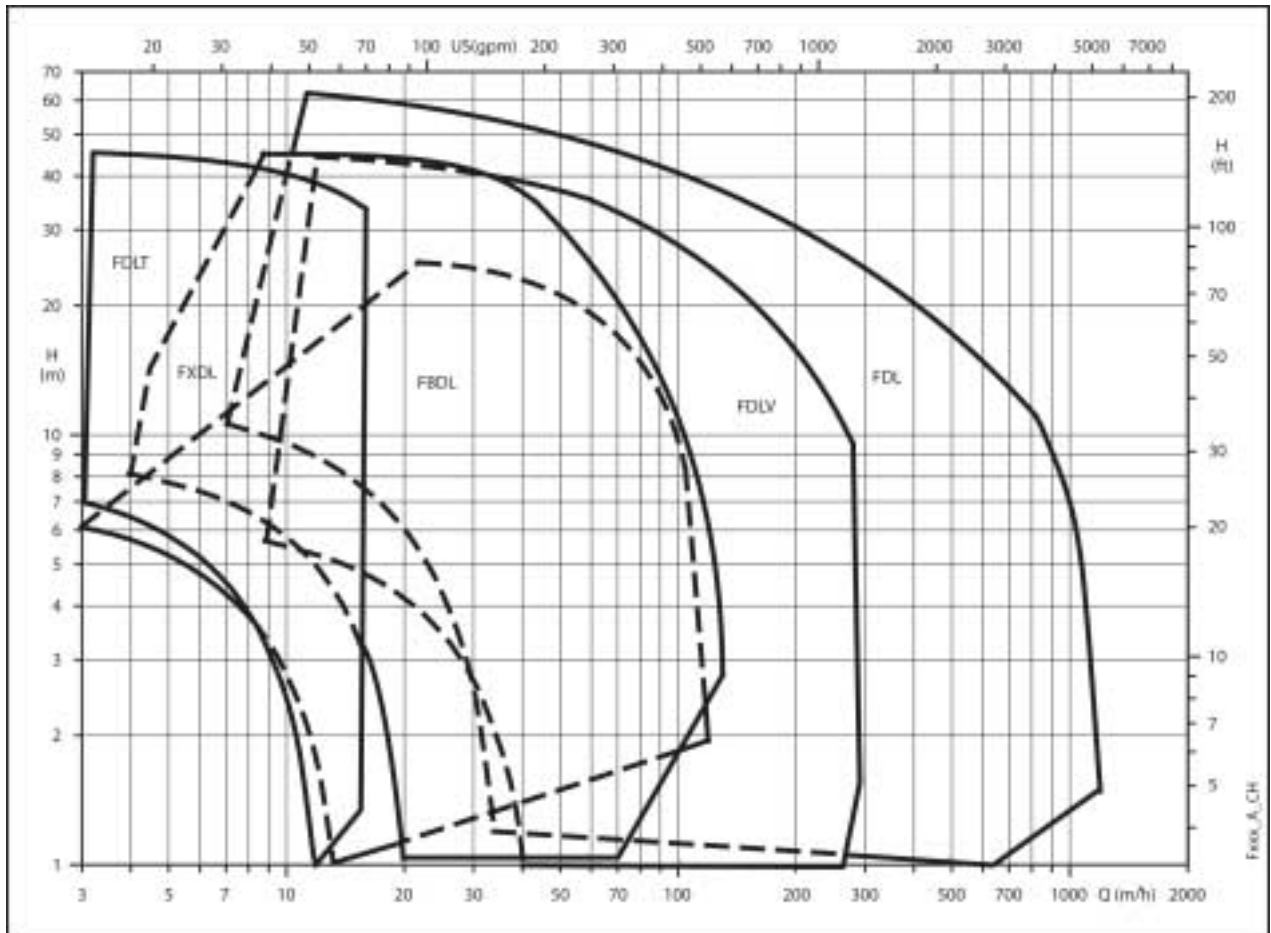

**FDL, FDLV, FDLT, FXDL, FBDL
SERIES**



EDITION 07-2003

Lowara



ITT Industries
Engineered for life

SELECTION GUIDE

General information regarding families

The FDL, FDLV, FDLT, FXDL and FBDL series of submersible electric pumps featured in the Lowara catalogue are designed to satisfy the most varied liquid handling requirements under even extreme conditions, thanks to the wide variety of materials of impeller and motor types.

In order to optimize the pump's performances and reduce energy consumption, it is very important to select the "correct" electric pump for the intended application.

Selecting the material

The electric pump's liquid end and casing are constantly in contact with the pumped liquid. The correct material is available for each type of liquid, ensuring the reliability of the electric pump.





MATERIAL	CHARACTERISTICS AND APPLICATIONS
250 cast iron, UNI-ISO 185	<ul style="list-style-type: none"> – Designed to handle clear water and sewage in civil sector applications, rainwater, effluent and active sludge. – Also suitable for moderately aggressive (pH > 6.5) and slightly abrasive liquids (sand up to 1 g/l).
Austenitic cast steel	<ul style="list-style-type: none"> – Suitable for some acids with high chloride content. – Suitable for seawater, salty water.
Steel bronze	<ul style="list-style-type: none"> – Especially suitable for seawater and salty water due to its high wear resistance.

Optional treatments

TYPE OF TREATMENT	CHARACTERISTICS AND APPLICATIONS
Cathodic protection on cast iron	<ul style="list-style-type: none"> – It consists of an anode of zinc in the cast iron pumps, in order to concentrate on it any parasite currents so that they will not corrode the pump body. – It enables the use of cast iron pumps with slightly salty waters.
Ceramic treatment	<ul style="list-style-type: none"> – It consists in the deposition of a coat of resin-bonded ceramic on the impeller and volute surfaces. – It ensures excellent resistance to abrasive and chemical agents. – It improves the surface finish for better hydraulic performance. – It cuts maintenance costs.

SELECTING THE IMPELLER

To optimise performance and consumption during the operation of submersible pumps, the liquid end should be selected based on the intended application of the pump, i.e. based mainly on the characteristics of the liquid to be pumped. The following table lists the impeller models recommended for the most common applications.

	TYPE OF IMPELLER	CHARACTERISTICS OF PUMPED LIQUID				
		CLEAN WATERS	SEWAGE	CONTAINING SUSPENDED FILAMENTS	CONTAINING SUSPENDED SOLIDS	CONTAINING ABRASIVE LIQUIDS
	Drainage Multiple blades, for clear waters	✓				
	Vortex vortex type	✓	✓	✓	✓	✓
	Single channel	✓	✓	✓	✓	
	Multiple channels Closed multiple channels	✓	✓		✓	✓
	Grinder Multiple blades, with grinder assembly on suction side		✓	✓		

TYPICAL APPLICATIONS

APPLICATIONS	IMPELLER TYPE				
	DRAINAGE	VORTEX	SINGLE CHANNEL	MULTIPLE CHANNELS	GRINDER
Purification systems		✓	✓	✓	
Sewers - single-family dwellings, small condominiums, multi-family dwellings		✓	✓	✓	✓
Sewers - campsites		✓	✓	✓	✓
Sewers - restaurants, hotels		✓	✓	✓	
Industry	✓	✓	✓	✓	
Sludge			✓	✓	
Land reclamation, irrigation, agriculture	✓		✓	✓	
Building yards	✓			✓	
Mining industry	✓	✓		✓	
Stock farming		✓	✓		
Aquaculture	✓	✓	✓	✓	

INSTALLATION

The FDL, FDLV, FDLT, FXDL and FBDL series of electric pumps can be installed in a number of configurations.

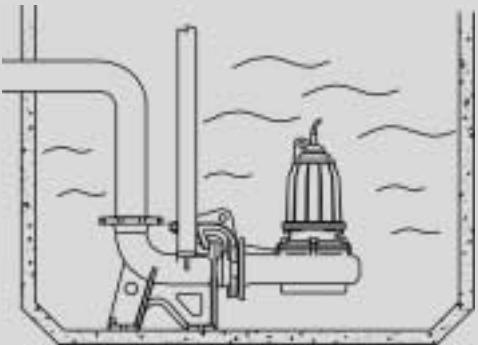
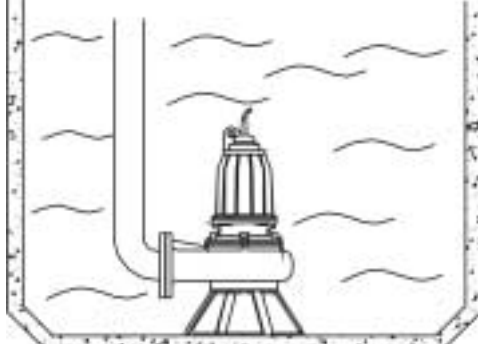
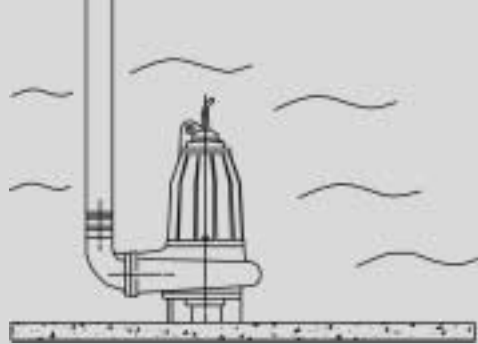
LOWERING SYSTEM		<p>Fixed submerged installation, with coupling foot and guide rails. Access to the electric pump for inspection or maintenance is quick and easy: to extract the pump, just lift it with a chain. The pump's stability and sealing are ensured by its weight. The pump's motor is cooled by the surrounding liquid. A minimum liquid level, indicated in the dimensional drawings for the different versions, must be guaranteed.</p>
TRIPOD STAND		<p>Portable submerged installation, with tripod stand. The pump's motor is cooled by the surrounding liquid. A minimum liquid level, indicated in the dimensional drawings for the different versions, must be guaranteed.</p>
90° DELIVERY UNION		<p>Free submerged installation with support feet and threaded bend. The pump's motor is cooled by the surrounding liquid. A minimum liquid level, indicated in the dimensional drawings for the different versions, must be guaranteed.</p>

Submersible electric pumps

FDL series



MARKET SECTORS

DOMESTIC, AGRICULTURAL, INDUSTRIAL, CONSTRUCTION, MUNICIPAL, MINING INDUSTRY.

APPLICATIONS

- Handling of sewage, liquids, wastewater and industrial sludge, draining of flooded excavations and marshy ground.



SPECIFICATIONS

- **Delivery:** up to 1140 m³/h.
- **Head:** up to 65 m.
 - Maximum liquid **temperature:** 25-40°C (see hydraulic performance table).
 - Maximum immersion depth: 20 m.
- **Passes solids** 30 to 105 mm in diameter
- Motor with IP 68 protection and class F insulation (155°C).
- Power supply: three-phase, 50 Hz.
- **Motor power:** up to 42 kW.
- Maximum number of starts per hour: approx. 20 (possibly more, depending on the application).

CONSTRUCTION CHARACTERISTICS

- Sturdy cast iron construction.
- Channel **impeller**.
- Double seal: Silicon Carbide / Silicon Carbide inner seal, Ceramic / Carbon upper seal or Nitrile Rubber seal ring with interposed oil chamber.
- Adjustable volute bottom cover to compensate for impeller wear and ensure stable long-lasting hydraulic performances.
- Oversized motor bearings.
- 10-metre power supply cable with neoprene sheath (H07RN-F).
- Moisture sensor in oil chamber (see electric data table).

OPTIONAL FEATURES

- Cathodic protection
- Ceramic treatment
- Cooling sleeve for dry installations
- Version without float.
- Flameproof construction (Exx).

ACCESSORIES / INSTALLATION

- Lowering system.
- 90° delivery union.
- Threaded flange for delivery port
- Tripod stand.
- Non-return ball valves.
- Floats for solids-laden waters.
- Command and control **panels**.

IDENTIFICATION CODE

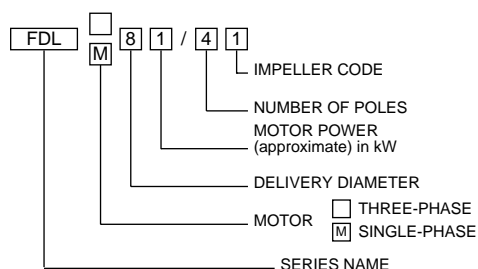

TABLE OF MATERIALS

PART	FDL MATERIAL
Impeller, Pump body, Motor casing, Volute bottom, Upper cover	250 CAST IRON UNI-ISO 185
Shaft	STAINLESS STEEL (AISI 420B)
Bearings	LIFETIME LUBRICATED BALL TYPE
Upper seal	CERAMIC-GRAPHITE OR NITRILE RUBBER SEAL RING
Lower seal	SILICON CARBIDE / SILICON CARBIDE
Gaskets	NITRILE RUBBER
Bolts and screws	STAINLESS STEEL (AISI 304)

FDL SERIES ELECTRICAL DATA (50 Hz)

PUMP TYPE	ABSORBED POWER*	min ⁻¹	ABSORBED CURRENT In(A)			STARTING CURRENT Isp (A)		ELECTRIC CABLE TYPE	STATOR THERMAL PROTECTION**	WATER SENSOR IN OIL CHAMBER**
			220-240 V	380-415 V		220-240 V	380-415 V			
			Δ	Y	Δ	A	A			
SINGLE-CHANNEL IMPELLER										
FDL 62-26	1,1	2850	4,3	2,5		19,9	11,5	4G1,5	NO	NO
FDL 62-25	1,3	2850	4,7	2,7		19,6	11,3	4G1,5	NO	NO
FDL 62-24	1,5	2850	4,8	2,8		20,3	11,8	4G1,5	NO	NO
FDL 62-23	1,6	2850	5,2	3		21,8	12,6	4G1,5	NO	NO
FDL 62-21	2,2	2850	6,4	3,7		36,5	21,1	4G2,5	NO	NO
FDL 815-23	11,3	2850	40,3		23,3	302,3	174,8	10G4	YES	YES
FDL 815-22	14,2	2850	46,0		26,6	345,1	199,5	10G4	YES	YES
FDL 815-21	17,5	2850	59,3		34,3	445,0	257,3	10G4	YES	YES
FDL 81-42	1,7	1450	5,4	3,1		21,5	12,4	4G2,5	NO	NO
FDL 82-41N	2,6	1450	8,1	4,7		37,4	21,6	4G2,5	NO	NO
FDL 83-41	2,8	1450	8,7	5		39,8	23,0	4G2,5	NO	NO
FDL 104-42	4,1	1450	13,8		8	72,0	41,6	12G1,5	YES	YES
FDL 104-41	4,2	1450	14,0		8,1	72,9	42,1	12G1,5	YES	YES
FDL 106-41	5,7	1450	18,0		10,4	100,8	58,2	12G2,5	YES	YES
FDL 107-41	5,9	1450	17,3		10	96,9	56,0	12G2,5	YES	YES
FDL 109-42	9,3	1450	32,0		18,5	217,6	125,8	10G4	YES	YES
FDL 109-41	11,2	1450	37,2		21,5	252,9	146,2	10G4	YES	YES
FDL 152-43	15,5	1450	49,3		28,5	364,9	210,9	10G4	YES	YES
FDL 152-42	17,5	1450	51,9		30	327,0	189,0	10G4	YES	YES
FDL 152-41	20,5	1450	64,0		37	403,3	233,1	10G4	YES	YES
MULTIPLE-CHANNEL IMPELLER										
FDL 64-22	3,5	2850	10,0	5,8		58,2	33,6	4G2,5	NO	NO
FDL 85-22	5,2	2850	15,2		8,8	99,0	57,2	12G1,5	YES	YES
FDL 86-21	6,6	2850	19,0		11	123,7	71,5	12G1,5	YES	YES
FDL 118-24	13	2850	40,5		23,4	303,6	175,5	10G4	YES	YES
FDL 118-23	14,8	2850	44,8		25,9	336,1	194,3	10G4	YES	YES
FDL 118-22	17,5	2850	51,9		30	389,3	225,0	10G4	YES	YES
FDL 118-21	18	2850	52,9		30,6	397,0	229,5	10G4	YES	YES
FDL 107-42	6,5	1450	19,9		11,5	111,4	64,4	12G2,5	YES	YES
FDL 101-41	10	1450	34,6		20	235,3	136,0	10G4	YES	YES
FDL 153-43	23,5	1450	71,8		41,5	452,3	261,5	10G4	YES	YES
FDL 153-43/1	26	1450	73,7		42,6	464,3	268,4	10G4	YES	YES
FDL 153-41/1	30	1450	88,2		51	555,8	321,3	10G4	YES	YES
FDL 153-42	30,6	1450	93,4		54	588,5	340,2	10G4	YES	YES
FDL 153-41	32	1450	93,4		54	588,5	340,2	10G4	YES	YES
FDL 154-43	35	1450	102,1		59	663,5	383,5	2X4G10+4G2,5	YES	YES
FDL 154-42	38	1450	112,5		65	730,9	422,5	2X4G10+4G2,5	YES	YES
FDL 154-41	42	1450	124,6		72	809,6	468,0	2X4G10+4G2,5	YES	YES
FDL 102-61	3	950	10,4		6	54,0	31,2	12G1,5	YES	YES
FDL 158-61	8,7	950	27,7		16	174,4	100,8	10G4	YES	YES
FDL 151-62	10,5	950	35,8		20,7	186,2	107,6	10G4	YES	YES
FDL 151-61	13	950	41,5		24	215,9	124,8	10G4	YES	YES
FDL 201-63	9,3	950	27,7		16	143,9	83,2	10G4	YES	YES
FDL 201-62	11,2	950	31,7		18,3	164,6	95,2	10G4	YES	YES
FDL 201-61	13,6	950	38,6		22,3	200,6	116,0	10G4	YES	YES
FDL 252-62	17,5	950	55,4		32	287,9	166,4	2X4G4+4G2,5	YES	YES
FDL 253-64	24	950	65,7		38	341,8	197,6	2X4G4+4G2,5	YES	YES
FDL 252-61	24,5	950	70,9		41	368,8	213,2	2X4G4+4G2,5	YES	YES
FDL 253-63	26	950	74,0		42,8	407,2	235,4	2X4G4+4G2,5	YES	YES
FDL 253-62	37	950	103,8		60	570,9	330,0	2X4G4+4G2,5	YES	YES
FDL 253-61	38,6	950	110,7		64	609,0	352,0	2X4G4+4G2,5	YES	YES

*Maximum values within the operating range

Fdl-2p-4p-6p50_b_te

**Featured in the standard version

**FDL SERIES, 2 POLE
OPERATING CHARACTERISTICS AT 50 Hz**

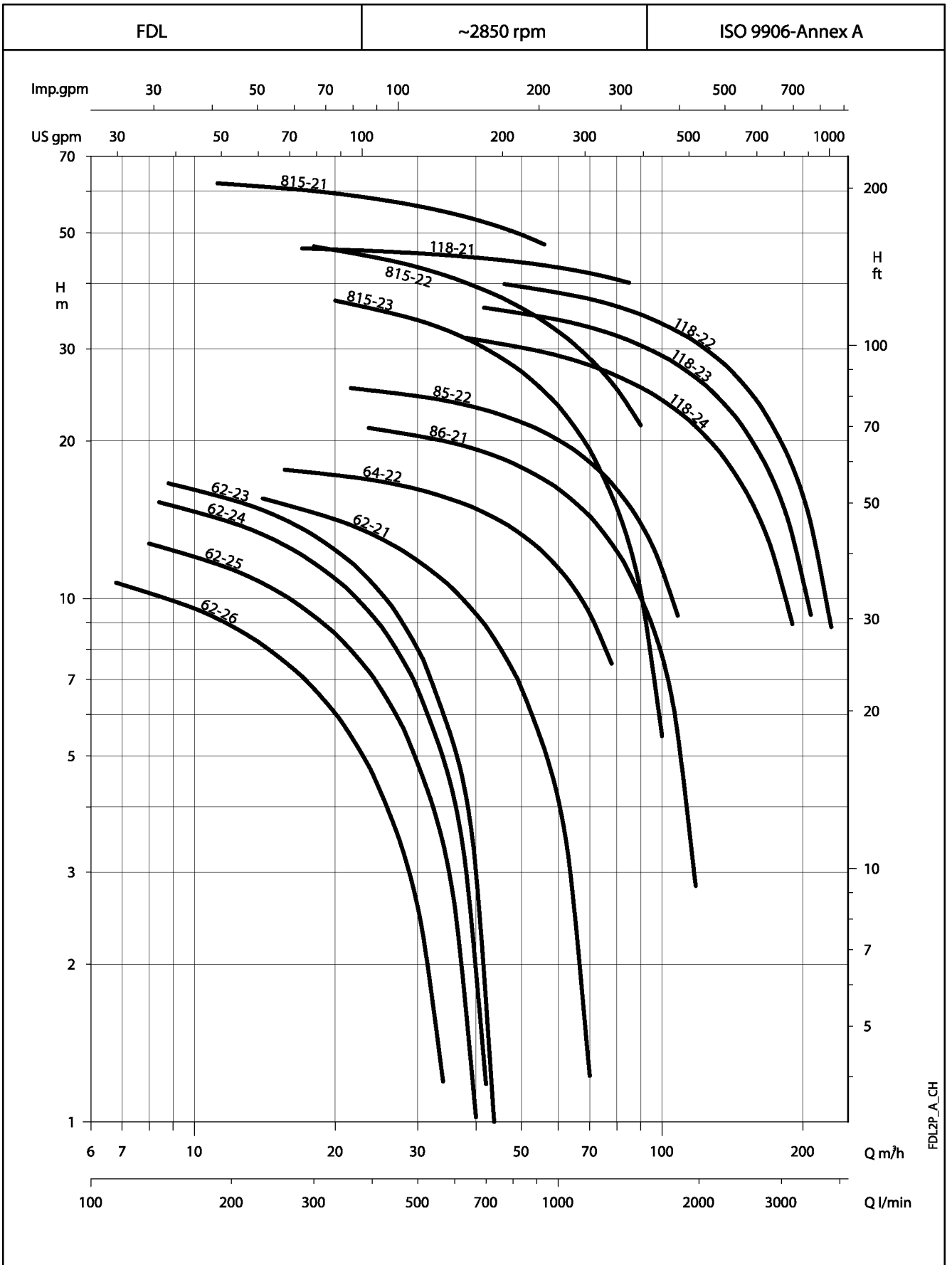

FDL2P_A_CH

**FDL SERIES, 4 POLE
OPERATING CHARACTERISTICS AT 50 Hz**

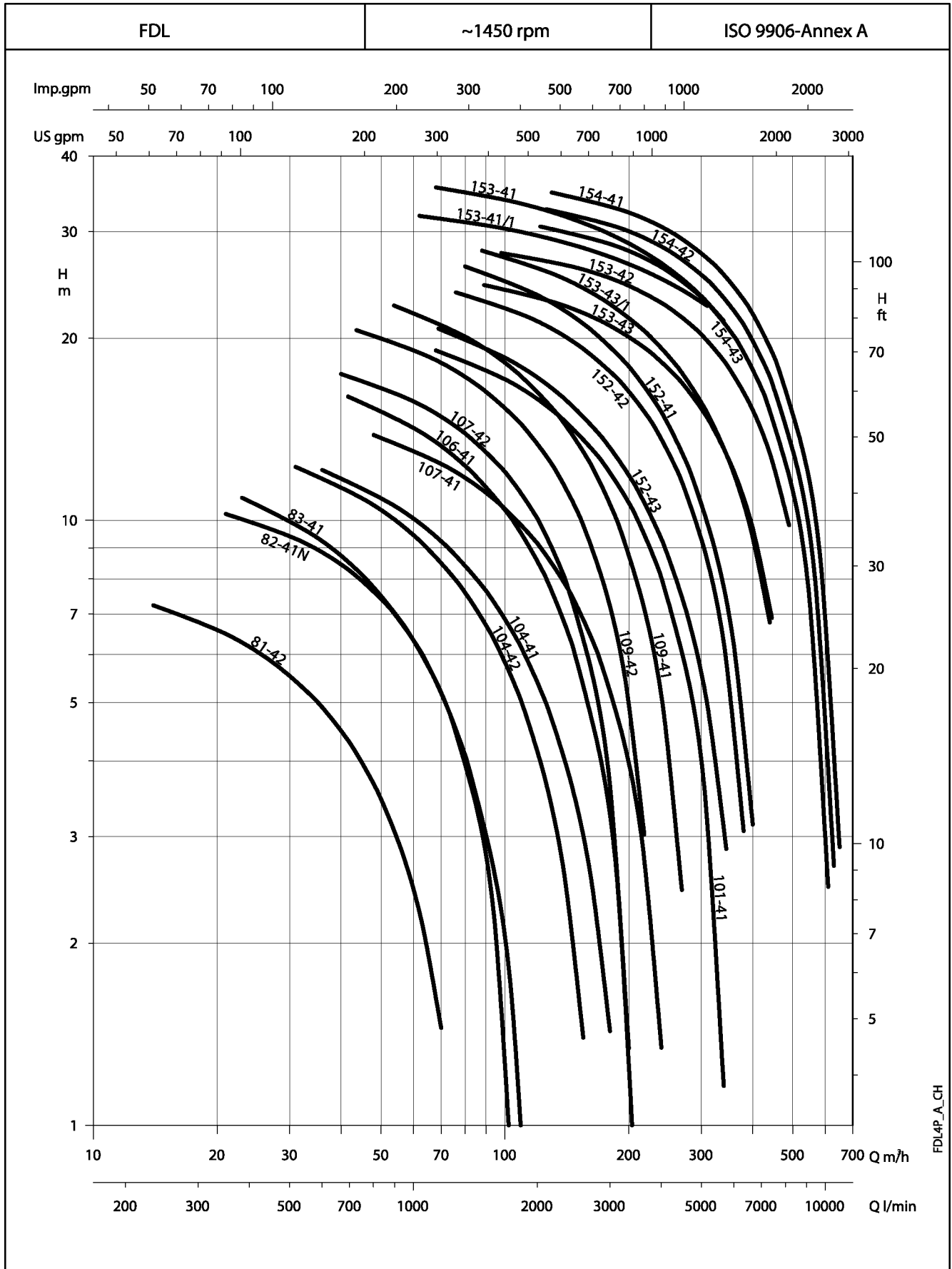

FDL4P_A_CH

**FDL SERIES, 6 POLE
OPERATING CHARACTERISTICS AT 50 Hz**

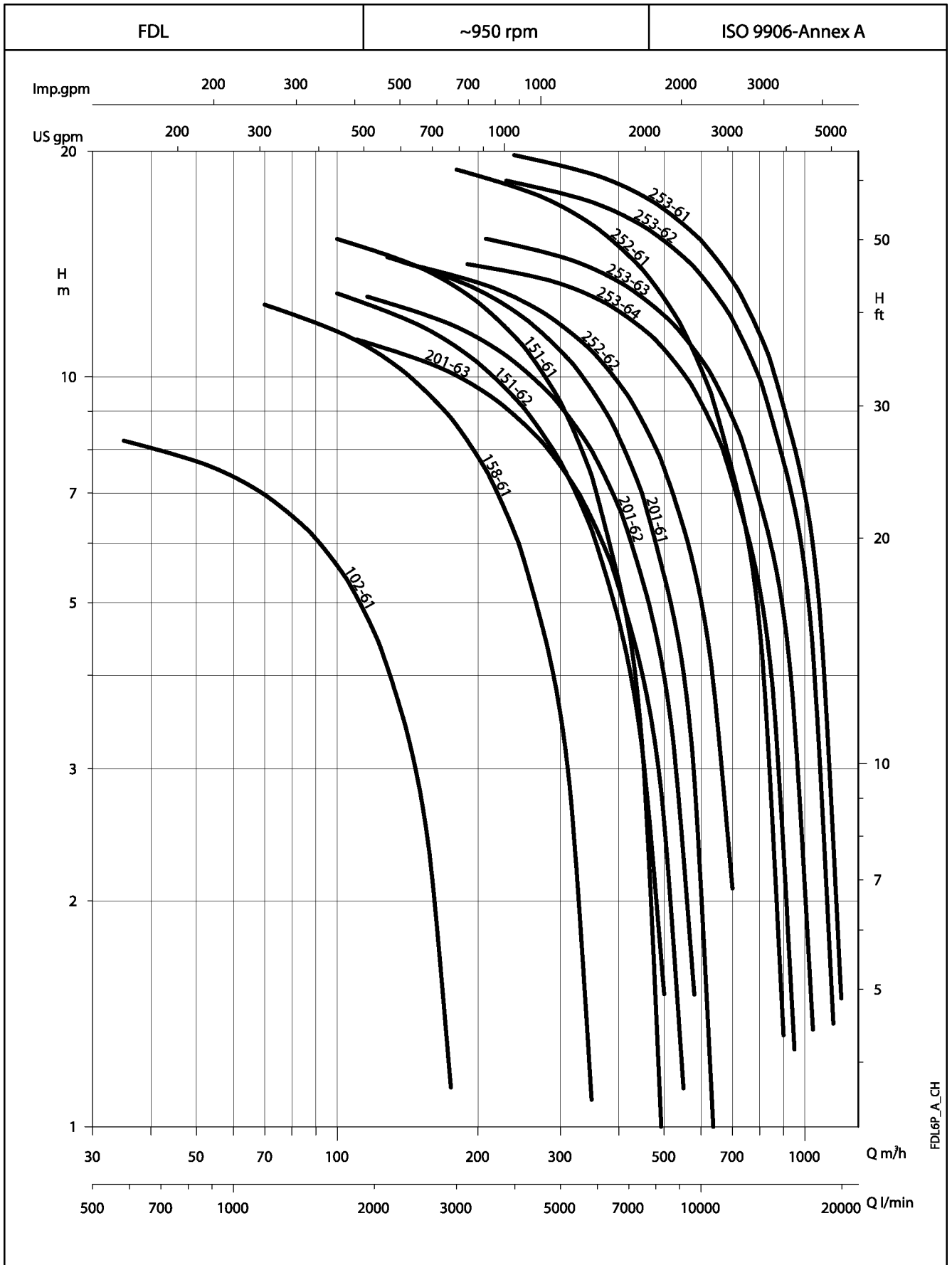

FDL6P_A_CH

FDL SERIES, 6 POLE HYDRAULIC PERFORMANCE TABLE

PUMP TYPE	ABS. POW.	rpm	Q = DELIVERY													DNM	PASSES SOLIDS UP TO (mm)	MAX LIQUID TEMP. (°C)
			l/min 0	75	150	300	400	500	600	800	1000	1200	1600	1800				
			m³/h 0	4,5	9	18	24	30	36	48	60	72	96	108				
			H = TOTAL HEAD METERS COLUMN OF WATER															
FDL 62-26	1,1	2850	13,2	11,5	9,9	6,7	4,6	2,6								65	30	40
FDL 62-25	1,3	2850	15,4	13,9	12,4	9,3	7,1	4,9	2,6							65	30	40
FDL 62-24	1,5	2850	18,1	16,6	15,1	11,7	9,3	6,7	4,0							65	30	40
FDL 62-23	1,6	2850	19,4	18,0	16,5	13,2	10,7	8,0	5,1							65	30	40
FDL 62-21	2,2	2850	18,5	17,6	16,6	14,6	13,3	11,8	10,4	7,3	4,1					70	30	40
FDL 64-22	3,5	2850	18,6	18,4	18,1	17,4	16,8	16,2	15,4	13,6	11,4	8,9				70	30	25
FDL 85-22	5,2	2850	23,0	22,7	22,4	21,7	21,1	20,5	19,8	18,1	16,2	14,0	8,7	5,6		DN 80	30	40
FDL 86-21	6,6	2850	26,7	26,5	26,2	25,6	25,0	24,4	23,7	22,0	20,1	17,9	12,4	9,3		DN 80	30	40
FDL 815-23	11,3	2850	42,4	41,3	40,1	37,7	35,9	34,0	32,1	27,9	23,3	18,4	7,4			DN 80	40	40
FDL 815-22	14,2	2850	53,2	51,7	50,1	47,1	45,0	42,9	40,9	36,6	32,4	28,0				DN 80	40	40
FDL 815-21	17,5	2850	65,5	64,2	62,8	60,0	58,2	56,2	54,3	50,3						DN 80	40	40
FDL 81-42	1,7	1450	9,5	8,9	8,3	7,1	6,3	5,5	4,8	3,4	2,0					DN 80	65	40
FDL 82-41N	2,6	1450	13,3	12,7	12,2	11,1	10,4	9,7	8,9	7,5	6,0	4,5	1,4			DN 80	65	40
FDL 83-41	2,8	1450	14,0	13,4	12,8	11,6	10,8	10,0	9,2	7,8	6,3	5,0	2,4	1,2		DN 80	76	40
PUMP TYPE	ABS. POW.	rpm	Q = DELIVERY													DNM	PASSES SOLIDS UP TO (mm)	MAX LIQUID TEMP. (°C)
			l/min 0	600	1000	1200	1400	2200	2900	3400	4400	5200	6800	7800				
			m³/h 0	36	60	72	84	132	174	204	264	312	408	468				
			H = TOTAL HEAD METERS COLUMN OF WATER															
FDL 118-24	13,0	2850	35,0	31,7	29,1	27,7	26,1	19,2	12,0							DN 100	40	40
FDL 118-23	14,8	2850	39,2	36,5	34,1	32,7	31,3	24,2	16,6	10,2						DN 100	40	40
FDL 118-22	17,5	2850	43,5	40,8	38,5	37,1	35,7	28,7	21,1	14,8						DN 100	40	40
FDL 118-21	18,0	2850	47,8	45,2	42,9	41,6	40,2									DN 100	40	40
FDL 107-42	6,5	1450	20,7	17,8	15,7	14,7	13,6	8,8	4,3							DN 100	60	40
FDL 101-41	10,0	1450	23,2	21,0	19,6	18,8	18,1	15,1	12,4	10,4	6,4	3,1				DN 100	80	40
FDL 153-43	23,5	1450	27,3	26,2	25,5	25,1	24,7	22,9	21,2	19,9	17,1	14,7	9,2			DN 150	100	40
FDL 153-43/1	26,0	1450	32,6	30,7	29,4	28,8	28,1	25,5	23,1	21,4	17,8	14,9	8,9			DN 150	80	40
FDL 153-41/1	30,0	1450	34,4	32,9	31,9	31,5	31,0	29,1	27,5	26,4	24,2					DN 150	80	40
FDL 153-42	30,6	1450	29,8	29,1	28,6	28,3	28,0	26,7	25,3	24,3	21,9	19,7	14,8	11,2		DN 150	100	40
FDL 153-41	32,0	1450	39,0	37,1	35,9	35,3	34,7	32,2	30,0	28,5	25,4	22,8				DN 150	80	40
FDL 102-61	3,0	950	9,1	8,2	7,4	6,9	6,4	3,9	1,2							DN 100	80	40
FDL 158-61	8,7	950	14,5	13,5	12,8	12,4	12,0	10,4	8,9	7,7	5,1	2,9				DN 150	80	40
FDL 151-62	10,5	950	15,2	14,4	13,8	13,6	13,3	12,2	11,1	10,3	8,7	7,4	4,5	2,6		DN 150	100	40
FDL 151-61	13,0	950	17,4	16,7	16,2	15,9	15,6	14,5	13,3	12,5	10,5	8,8	5,0	2,3		DN 150	100	40
PUMP TYPE	ABS. POW.	rpm	Q = DELIVERY													DNM	PASSES SOLIDS UP TO (mm)	MAX LIQUID TEMP. (°C)
			l/min 0	2500	3400	3900	5200	6000	7800	8900	10000	11333	15000	19000				
			m³/h 0	150	204	234	312	360	468	534	600	680	900	1140				
			H = TOTAL HEAD METERS COLUMN OF WATER															
FDL 154-43	35,0	1450	33,5	29,7	27,7	26,5	22,8	20,2	13,4	8,6	3,3					DN 150	100	40
FDL 154-42	38,0	1450	35,8	31,9	29,9	28,6	24,9	22,3	15,4	10,6	5,3					DN 150	100	40
FDL 154-41	42,0	1450	38,1	34,1	32,1	30,8	27,0	24,4	17,5	12,6	7,3					DN 150	100	40
FDL 201-63	9,3	950	12,8	10,6	9,6	9,0	7,4	6,3	3,5	1,6						DN 200	102	40
FDL 201-62	11,2	950	14,5	12,2	11,2	10,6	8,9	7,7	4,9	2,9						DN 200	102	40
FDL 201-61	13,6	950	16,5	14,0	13,0	12,4	10,6	9,4	6,4	4,4	2,3					DN 200	102	40
FDL 252-62	17,5	950	15,6	14,1	13,3	12,9	11,5	10,6	8,3	6,7	5,0	2,7				DN 250	105	40
FDL 253-64	24,0	950	14,8	14,4	14,1	13,9	13,2	12,7	11,4	10,4	9,3	7,8	2,6			DN 250	105	40
FDL 252-61	24,5	950	21,2	19,3	18,5	18,1	16,7	15,8	13,5	12,0	10,3	8,1	1,3			DN 250	105	40
FDL 253-63	26,0	950	16,4	15,7	15,3	15,1	14,4	13,9	12,5	11,6	10,6	9,2	4,7			DN 250	105	40
FDL 253-62	37,0	950	19,6	18,9	18,5	18,2	17,5	17,0	15,7	14,7	13,7	12,3	7,8	1,7		DN 250	105	40
FDL 253-61	38,6	950	21,2	20,5	20,1	19,8	19,1	18,6	17,2	16,3	15,2	13,8	9,3	3,1		DN 250	105	40
PUMP TYPE	ABS. POW.	rpm	Q = DELIVERY													DNM	PASSES SOLIDS UP TO (mm)	MAX LIQUID TEMP. (°C)
			l/min 0	500	800	1200	1600	1800	2500	2900	3400	3900	5200	6000				
			m³/h 0	30	48	72	96	108	150	174	204	234	312	360				
			H = TOTAL HEAD METERS COLUMN OF WATER															
FDL 104-42	4,1	1450	15,4	12,4	10,6	8,3	6,2	5,2	1,8							DN 100	78	40
FDL 104-41	4,2	1450	15,4	12,6	11,1	9,1	7,2	6,3	3,3	1,8						DN 100	78	40
FDL 106-41	5,7	1450	20,2	17,2	15,4	13,1	10,8	9,7	5,8	3,7	1,1					DN 100	78	40
FDL 107-41	5,9	1450	17,0	15,0	13,8	12,3	10,7	9,9	7,2	5,6	3,7	1,7				DN 100	100	40
FDL 109-42	9,3	1450	24,4	21,8	20,2	18,0	15,7	14,6	10,4	7,8	4,6					DN 100	90	40
FDL 109-41	11,2	1450	27,9	24,9	23,2	20,9	18,6	17,5	13,5	11,2	8,4	5,7				DN 100	90	40
FDL 152-43	15,5	1450	25,7	23,5	22,2	20,5	18,9	18,0	15,2	13,6	11,6	9,7	4,8			DN 150	100	40
FDL 152-42	17,5	1450	27,7	26,2	25,3	24,0	22,7	22,0	19,5	18,0	16,1	14,1	8,4	4,7		DN 150	100	40
FDL 152-41	20,5	1450	31,6	29,6	28,4	26,8	25,2	24,4	21,5	19,8	17,7	15,5	9,8	6,2		DN 150	100	40

PERFORMANCES MEASURED WITH PURE WATER AT 20°C

FDL_B_TH

**FDL SERIES
OPERATING CHARACTERISTICS AT 2850 rpm 50 Hz**

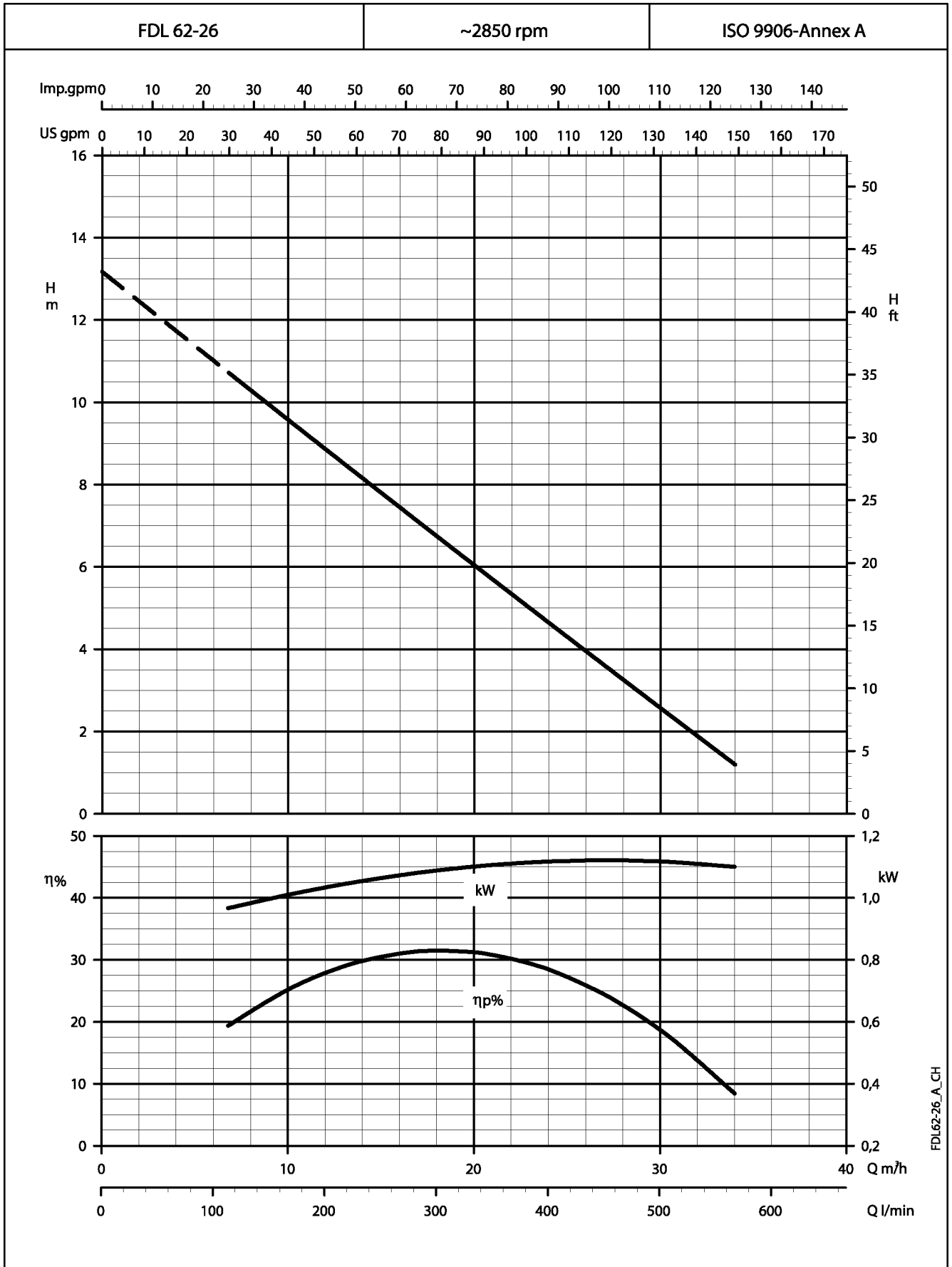

These performances are valid for liquids with density $\rho = 1.0 \text{ kg/dm}^3$ and kinematic viscosity $\gamma = 1 \text{ mm}^2/\text{s}$.

**FDL SERIES
OPERATING CHARACTERISTICS AT 2850 rpm 50 Hz**

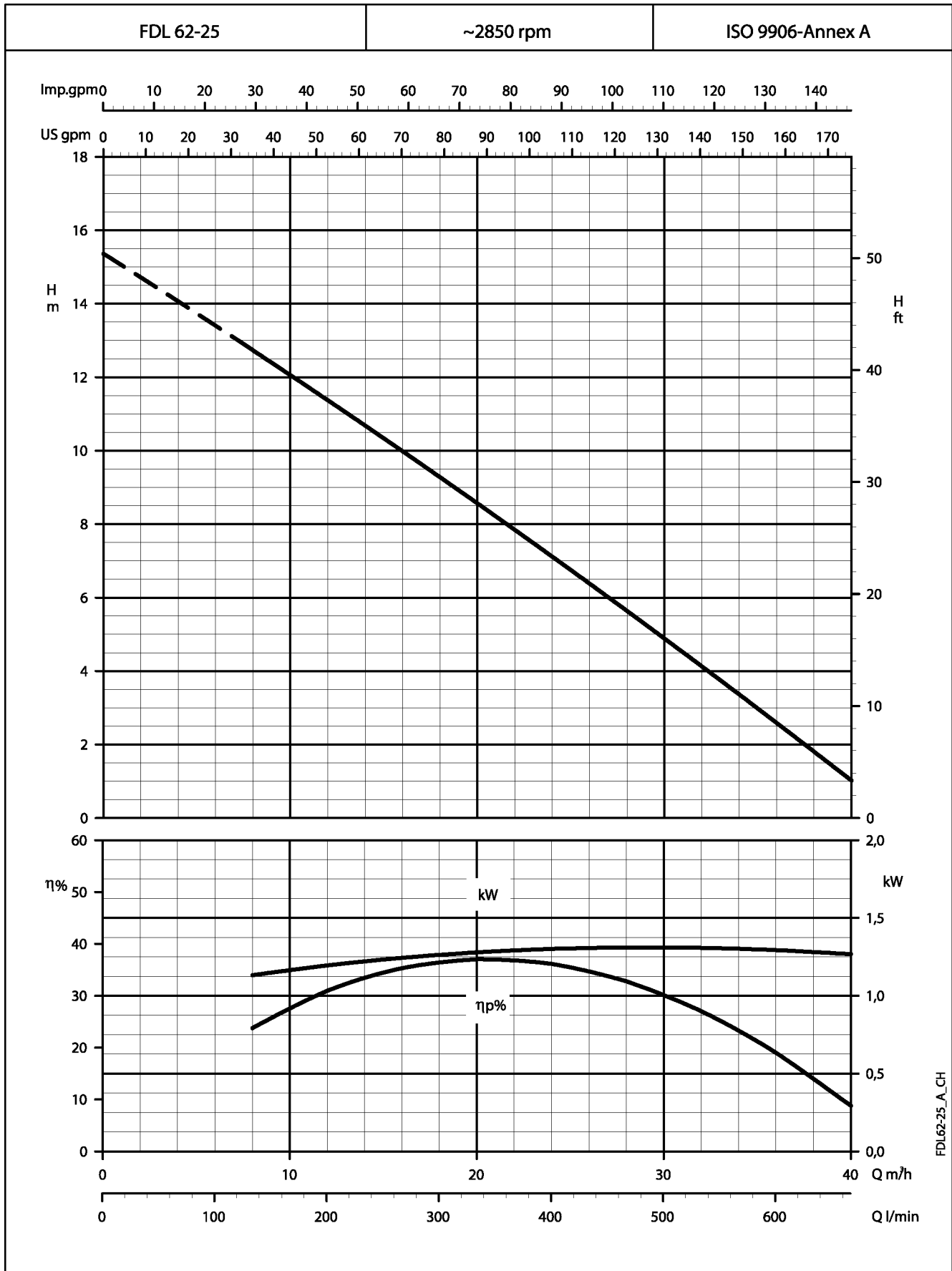

These performances are valid for liquids with density $\rho = 1.0 \text{ kg/dm}^3$ and kinematic viscosity $\nu = 1 \text{ mm}^2/\text{s}$.

**FDL SERIES
OPERATING CHARACTERISTICS AT 2850 rpm 50 Hz**

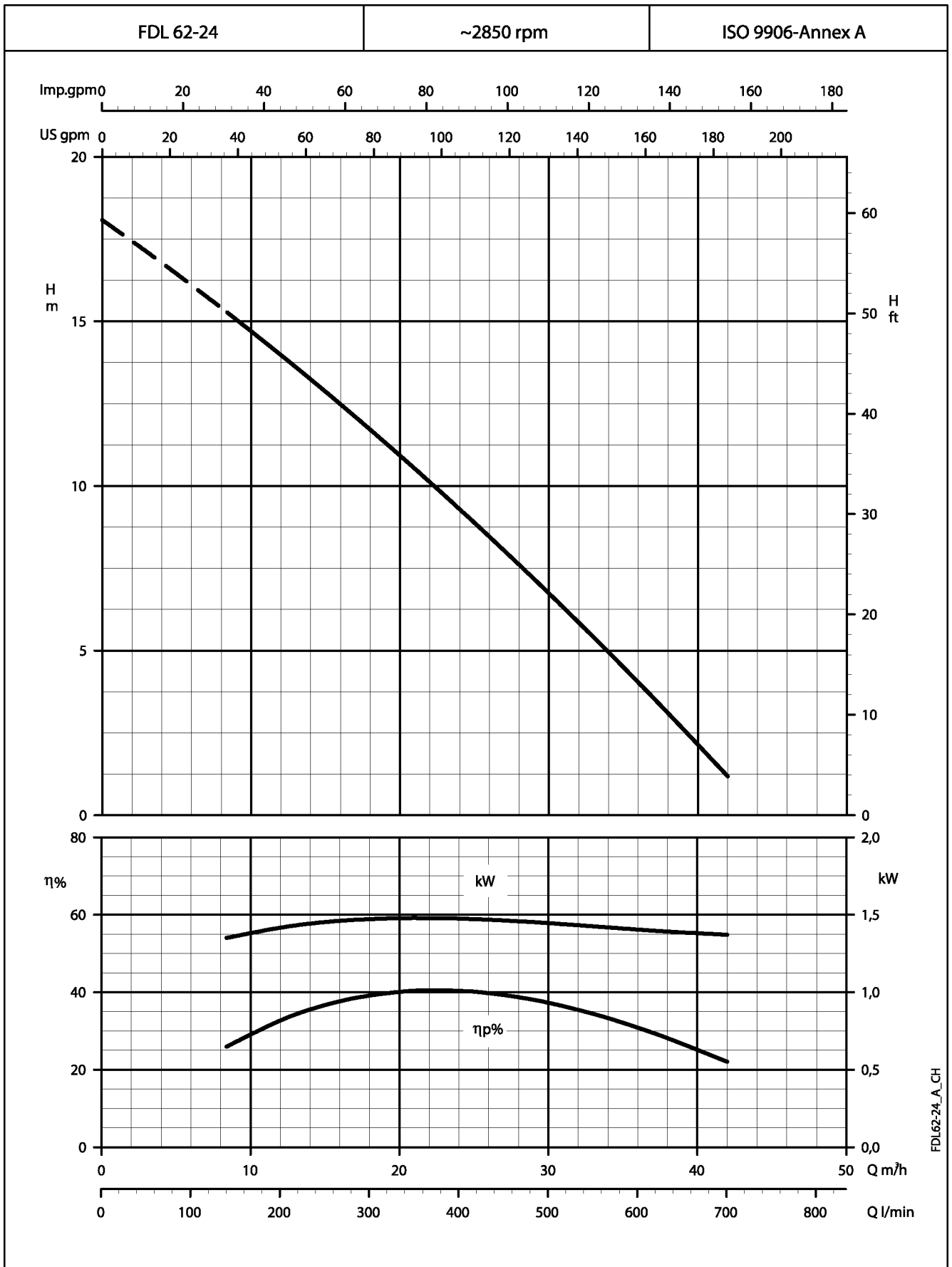

These performances are valid for liquids with density $\rho = 1.0 \text{ kg/dm}^3$ and kinematic viscosity $\gamma = 1 \text{ mm}^2/\text{s}$.

**FDL SERIES
OPERATING CHARACTERISTICS AT 2850 rpm 50 Hz**

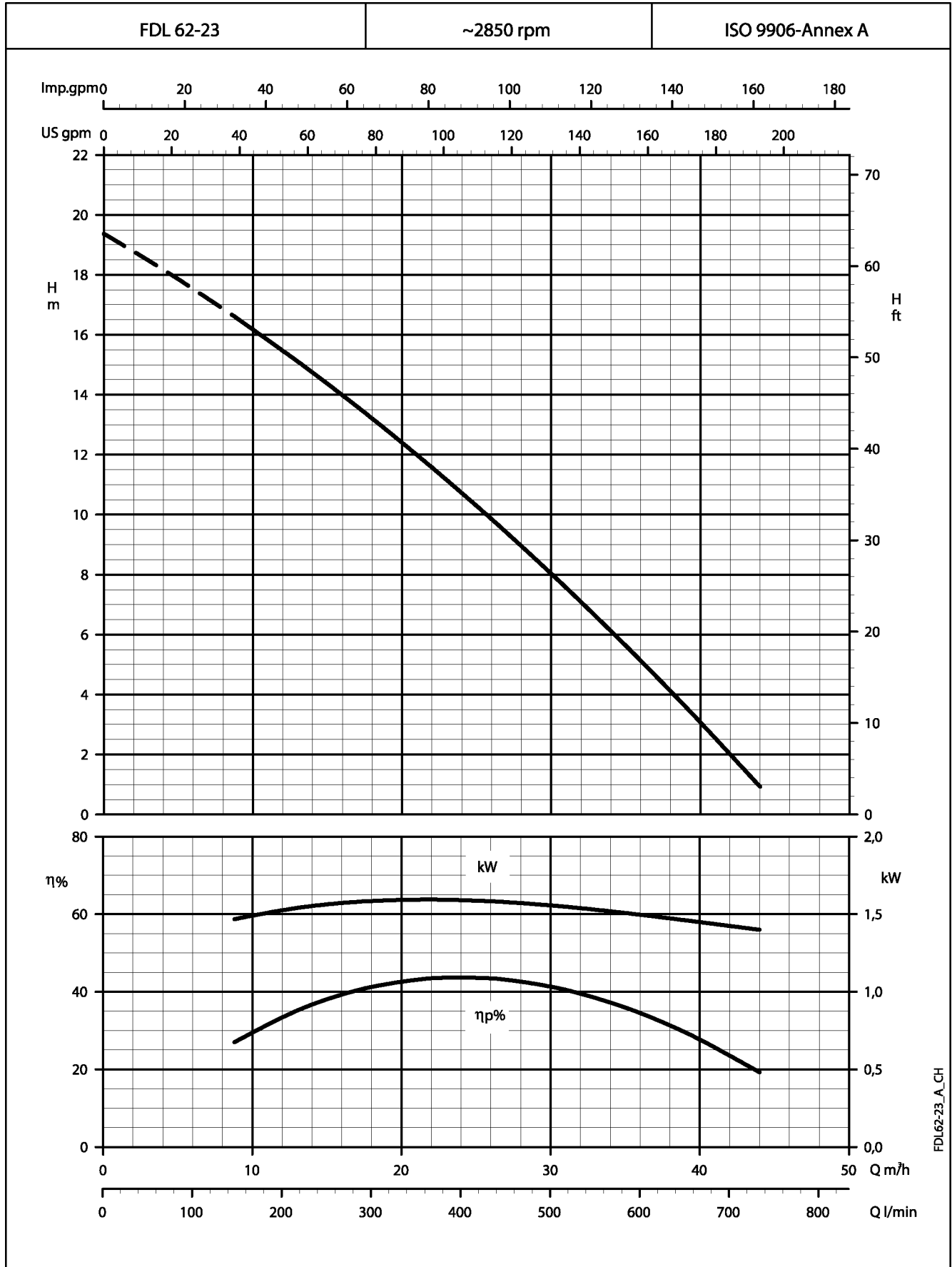

These performances are valid for liquids with density $\rho = 1.0 \text{ kg/dm}^3$ and kinematic viscosity $\nu = 1 \text{ mm}^2/\text{s}$.

**FDL SERIES
OPERATING CHARACTERISTICS AT 2850 rpm 50 Hz**

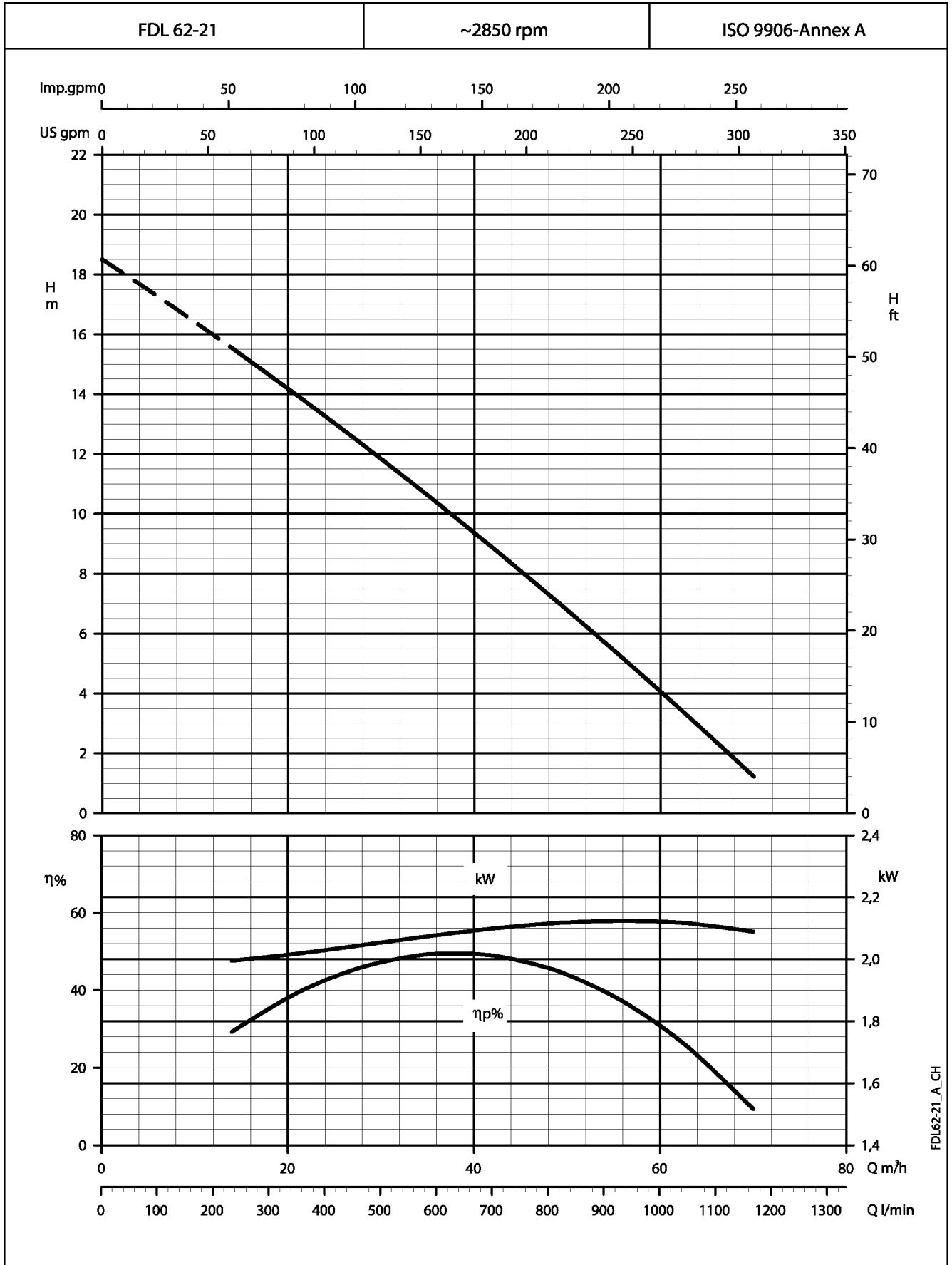

These performances are valid for liquids with density $\rho = 1.0 \text{ kg/dm}^3$ and kinematic viscosity $\gamma = 1 \text{ mm}^2/\text{s}$.

**FDL SERIES
OPERATING CHARACTERISTICS AT 2850 rpm 50 Hz**

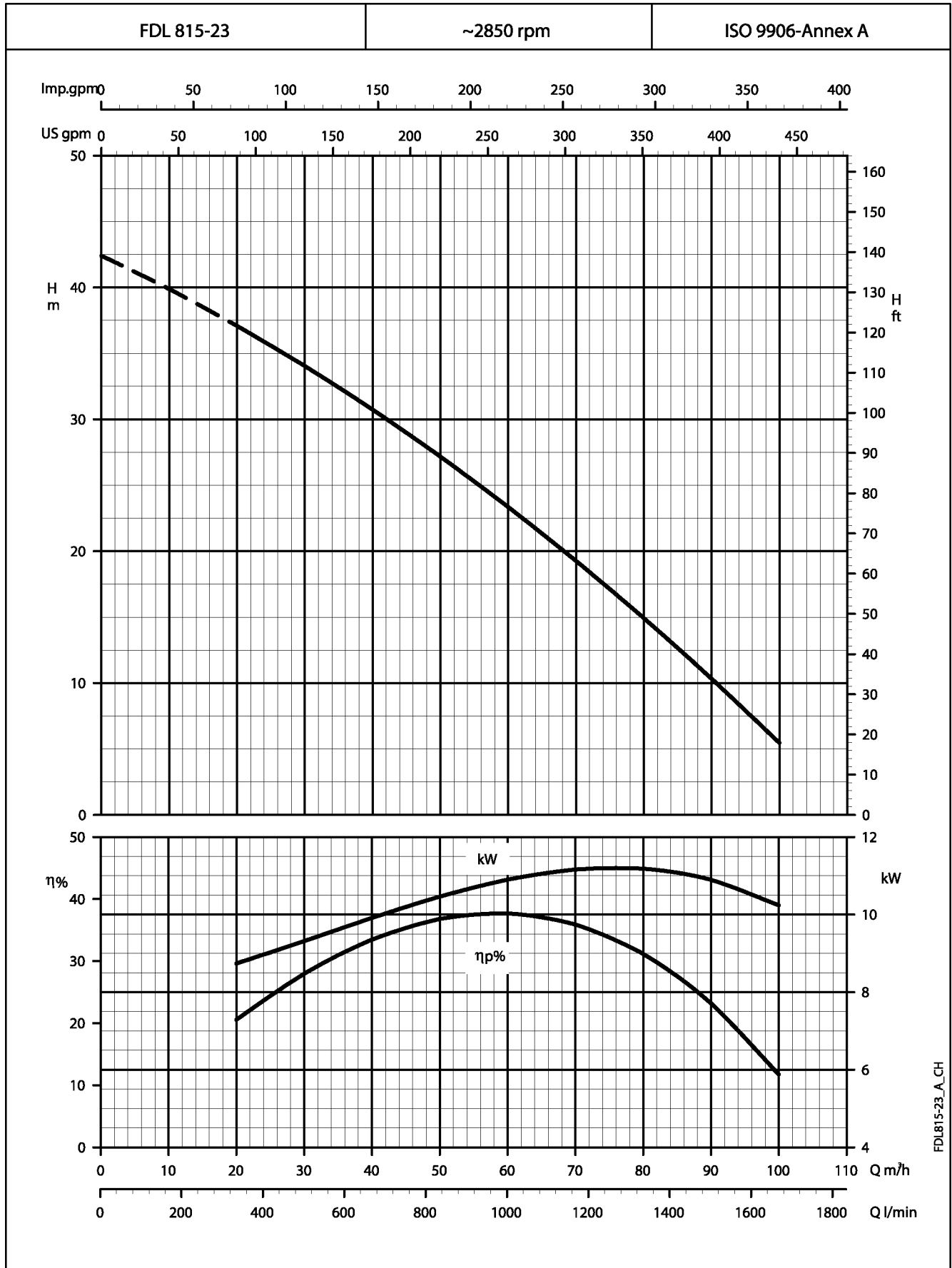

These performances are valid for liquids with density $\rho = 1.0 \text{ kg/dm}^3$ and kinematic viscosity $\nu = 1 \text{ mm}^2/\text{s}$.

**FDL SERIES
OPERATING CHARACTERISTICS AT 2850 rpm 50 Hz**

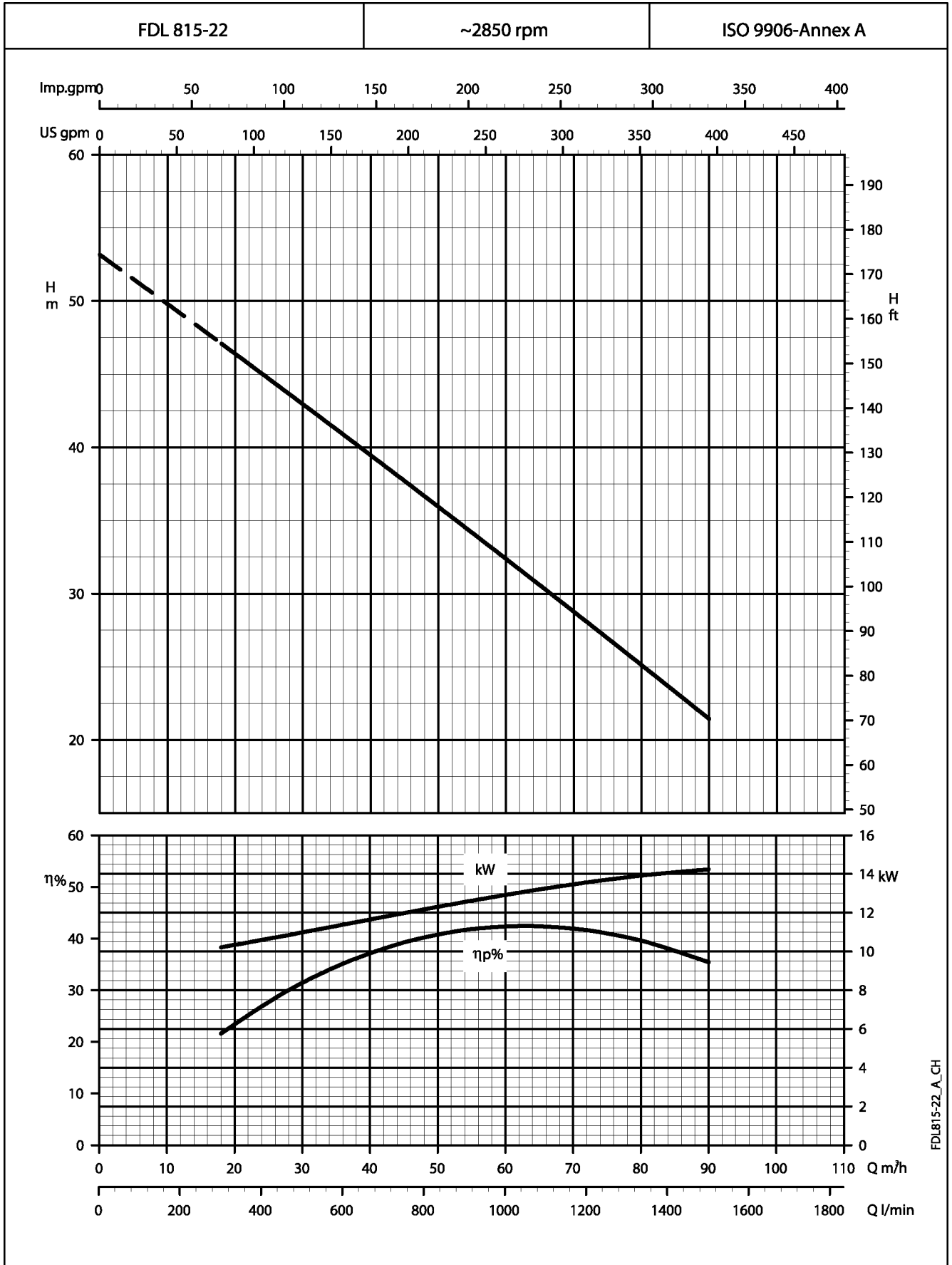

FDL815-22_A_CH

These performances are valid for liquids with density $\rho = 1.0 \text{ kg/dm}^3$ and kinematic viscosity $\gamma = 1 \text{ mm}^2/\text{s}$.

**FDL SERIES
OPERATING CHARACTERISTICS AT 2850 rpm 50 Hz**

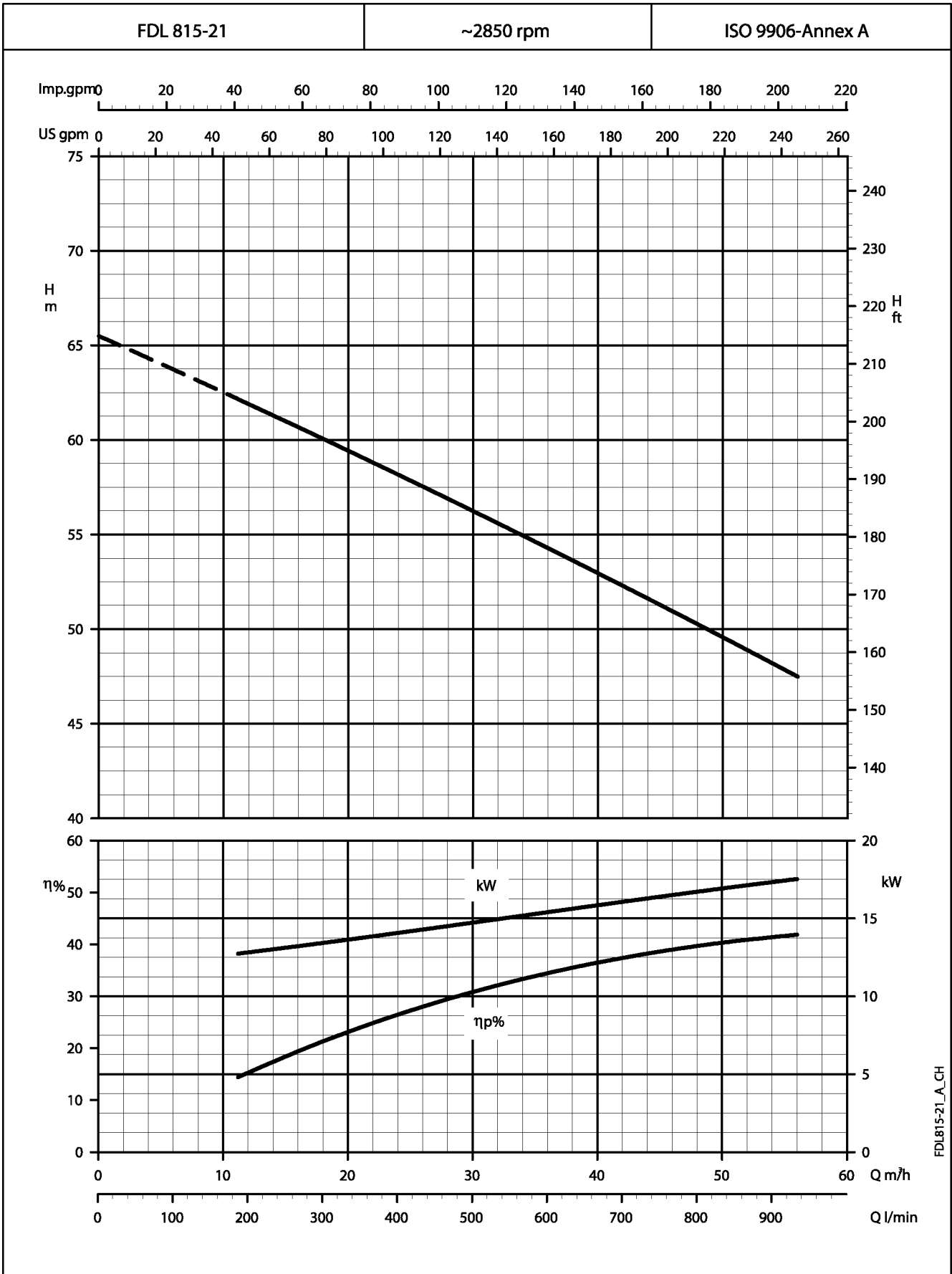

These performances are valid for liquids with density $\rho = 1.0 \text{ kg/dm}^3$ and kinematic viscosity $\nu = 1 \text{ mm}^2/\text{s}$.

**FDL SERIES
OPERATING CHARACTERISTICS AT 1450 rpm 50 Hz**

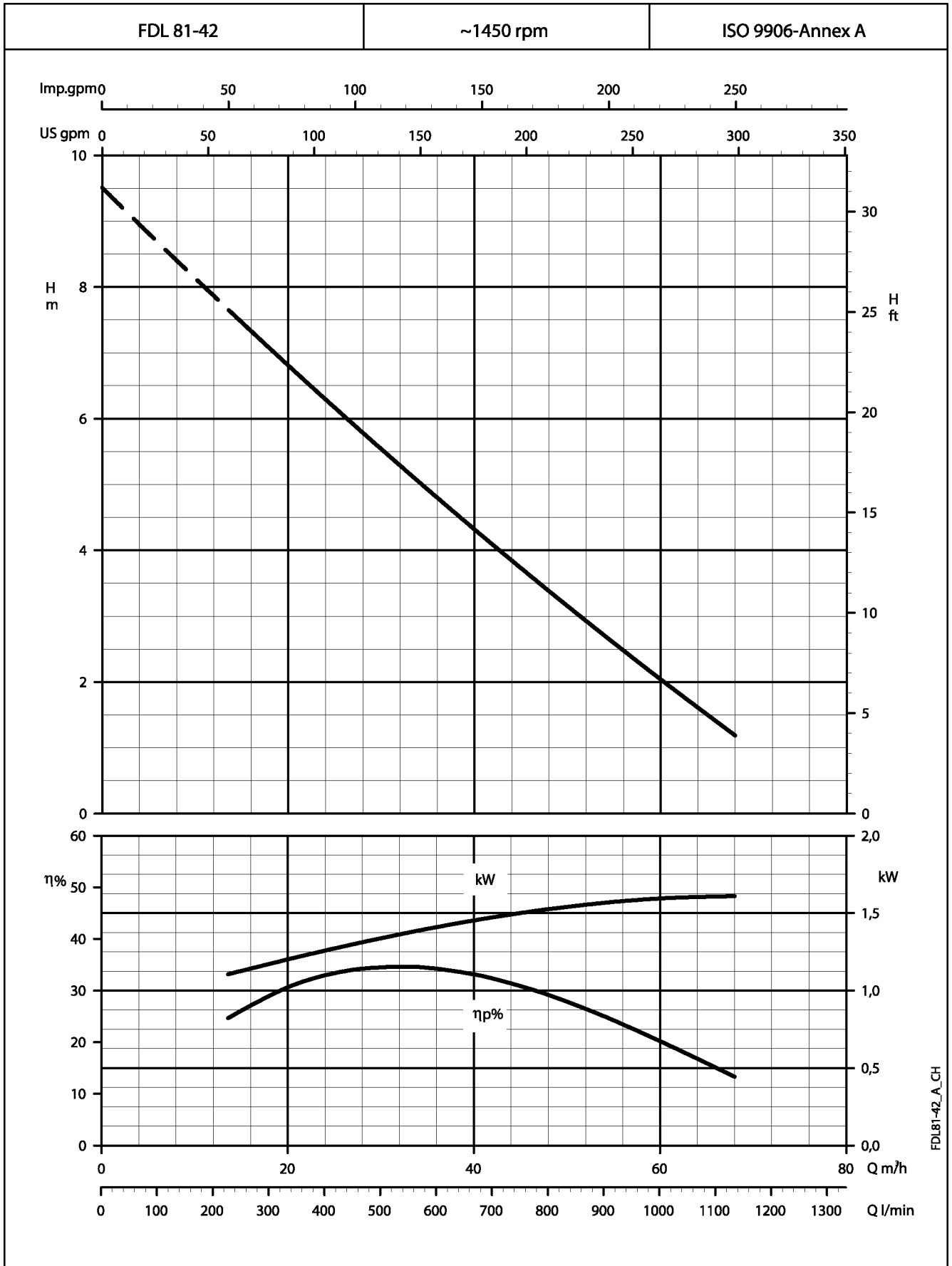

These performances are valid for liquids with density $\rho = 1.0 \text{ kg/dm}^3$ and kinematic viscosity $\gamma = 1 \text{ mm}^2/\text{s}$.

**FDL SERIES
OPERATING CHARACTERISTICS AT 1450 rpm 50 Hz**

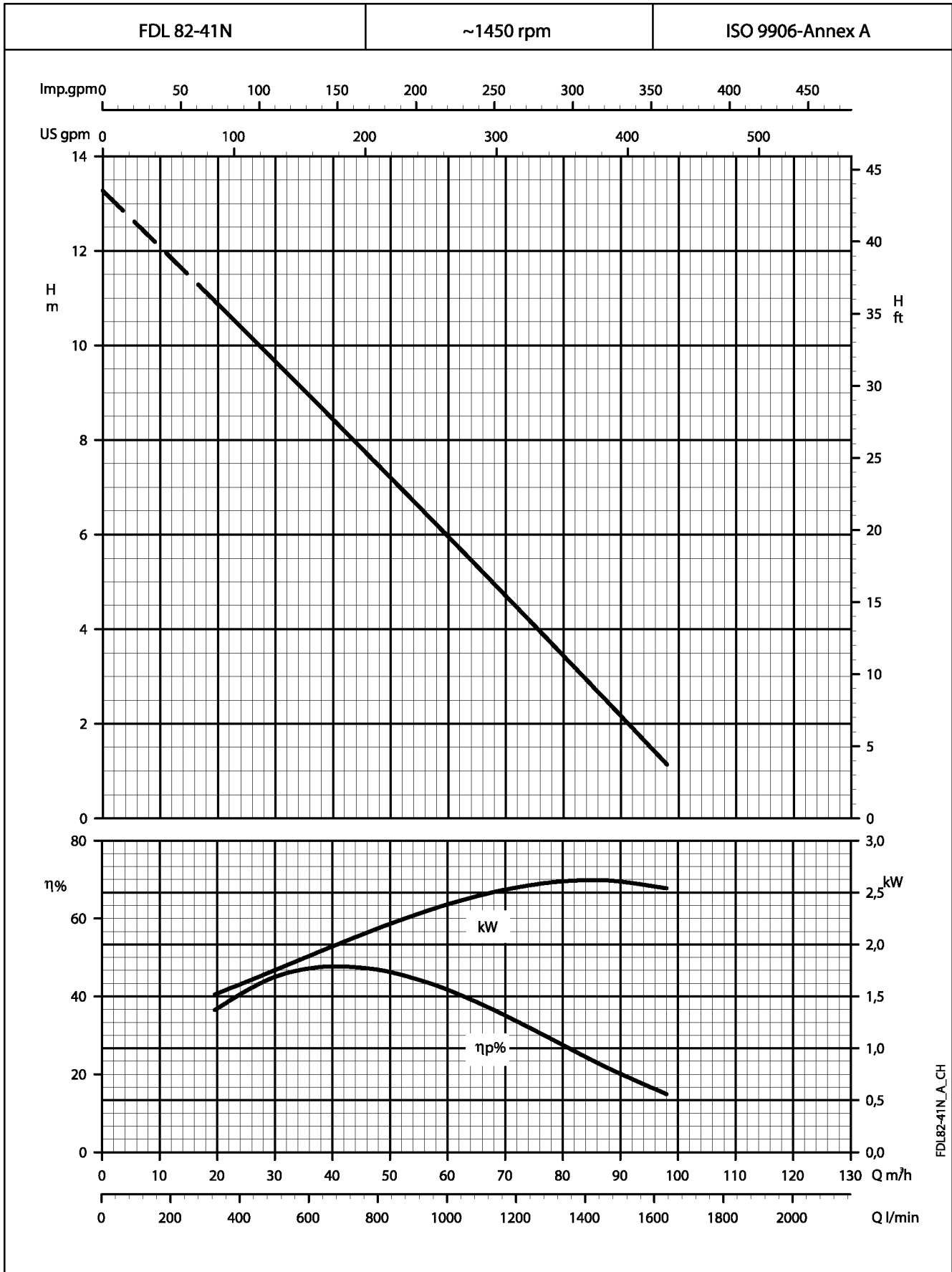

These performances are valid for liquids with density $\rho = 1.0 \text{ kg/dm}^3$ and kinematic viscosity $\gamma = 1 \text{ mm}^2/\text{s}$.

**FDL SERIES
OPERATING CHARACTERISTICS AT 1450 rpm 50 Hz**

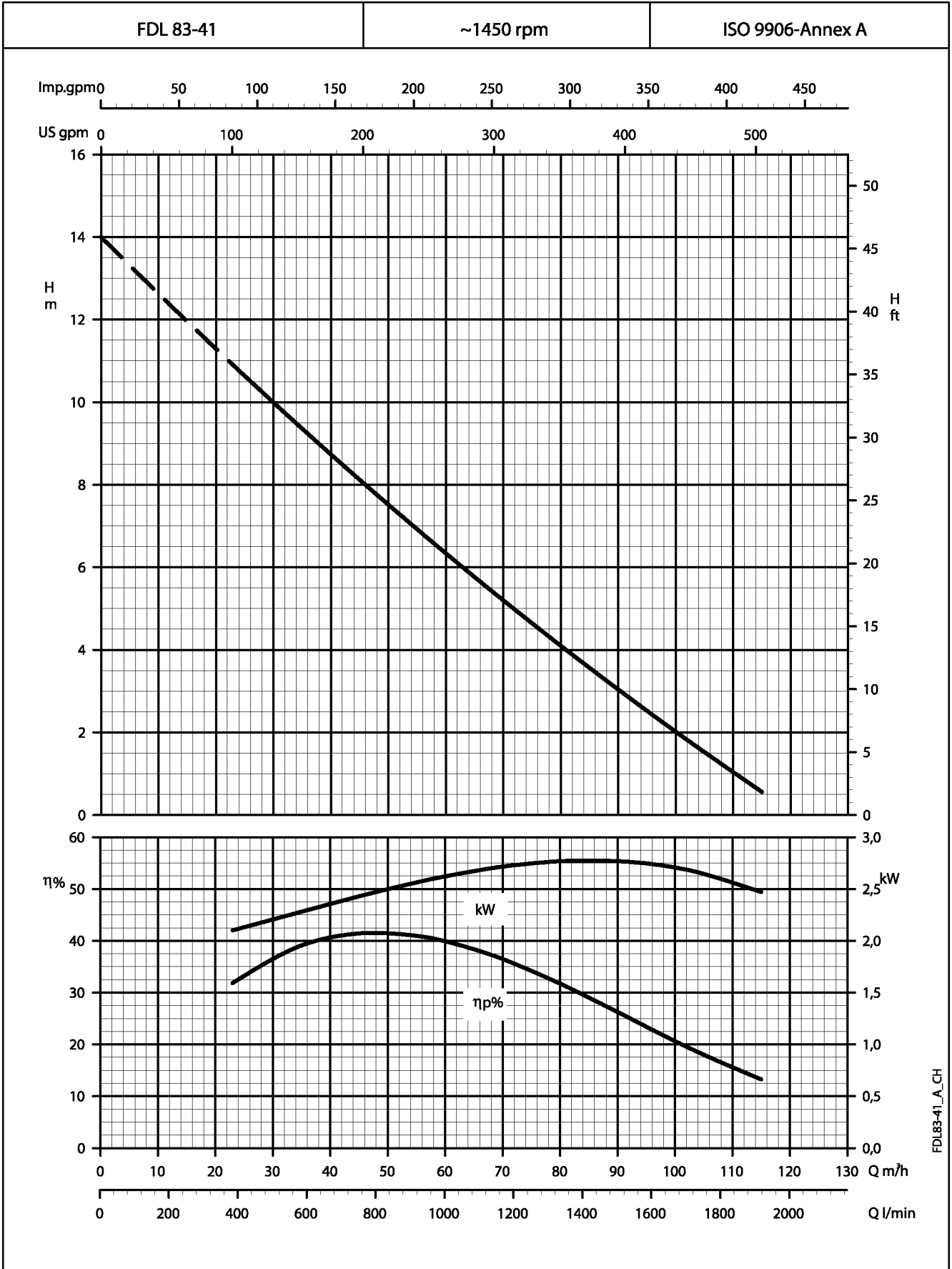

These performances are valid for liquids with density $\rho = 1.0 \text{ kg/dm}^3$ and kinematic viscosity $\gamma = 1 \text{ mm}^2/\text{s}$.

**FDL SERIES
OPERATING CHARACTERISTICS AT 1450 rpm 50 Hz**

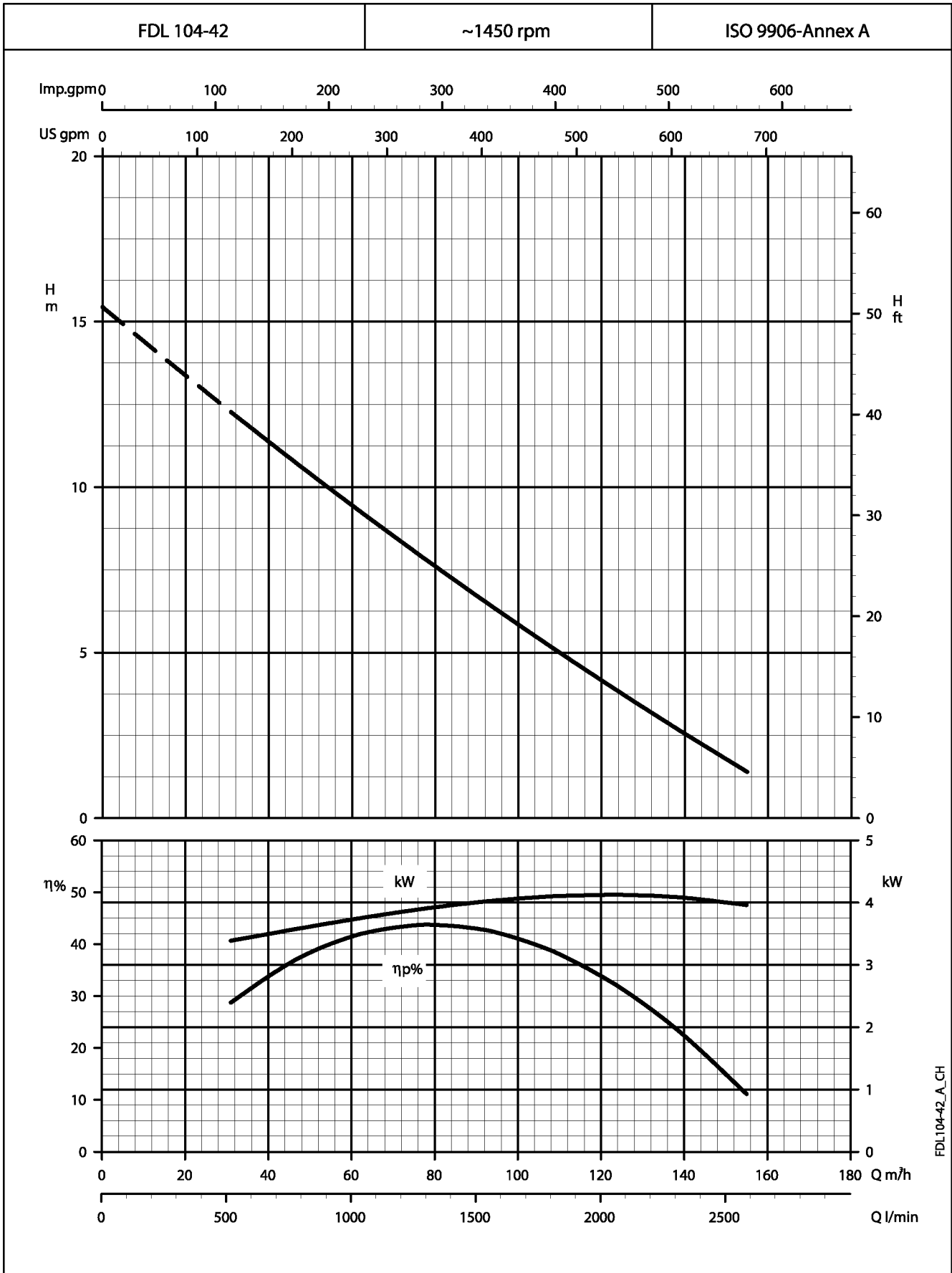

These performances are valid for liquids with density $\rho = 1.0 \text{ kg/dm}^3$ and kinematic viscosity $\gamma = 1 \text{ mm}^2/\text{s}$.

**FDL SERIES
OPERATING CHARACTERISTICS AT 1450 rpm 50 Hz**

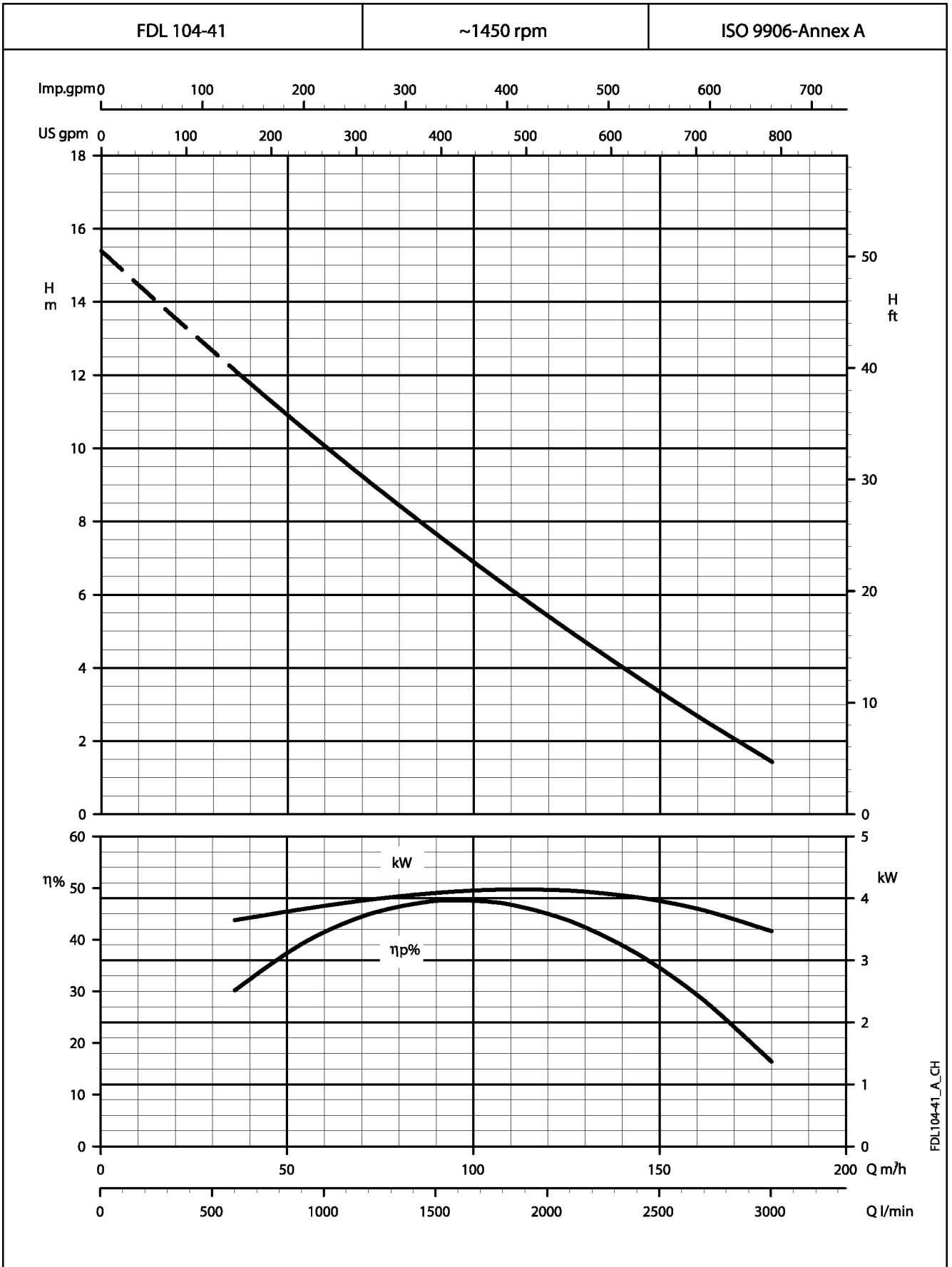

FDL104-41_A_CH

These performances are valid for liquids with density $\rho = 1.0 \text{ kg/dm}^3$ and kinematic viscosity $\gamma = 1 \text{ mm}^2/\text{s}$.

**FDL SERIES
OPERATING CHARACTERISTICS AT 1450 rpm 50 Hz**

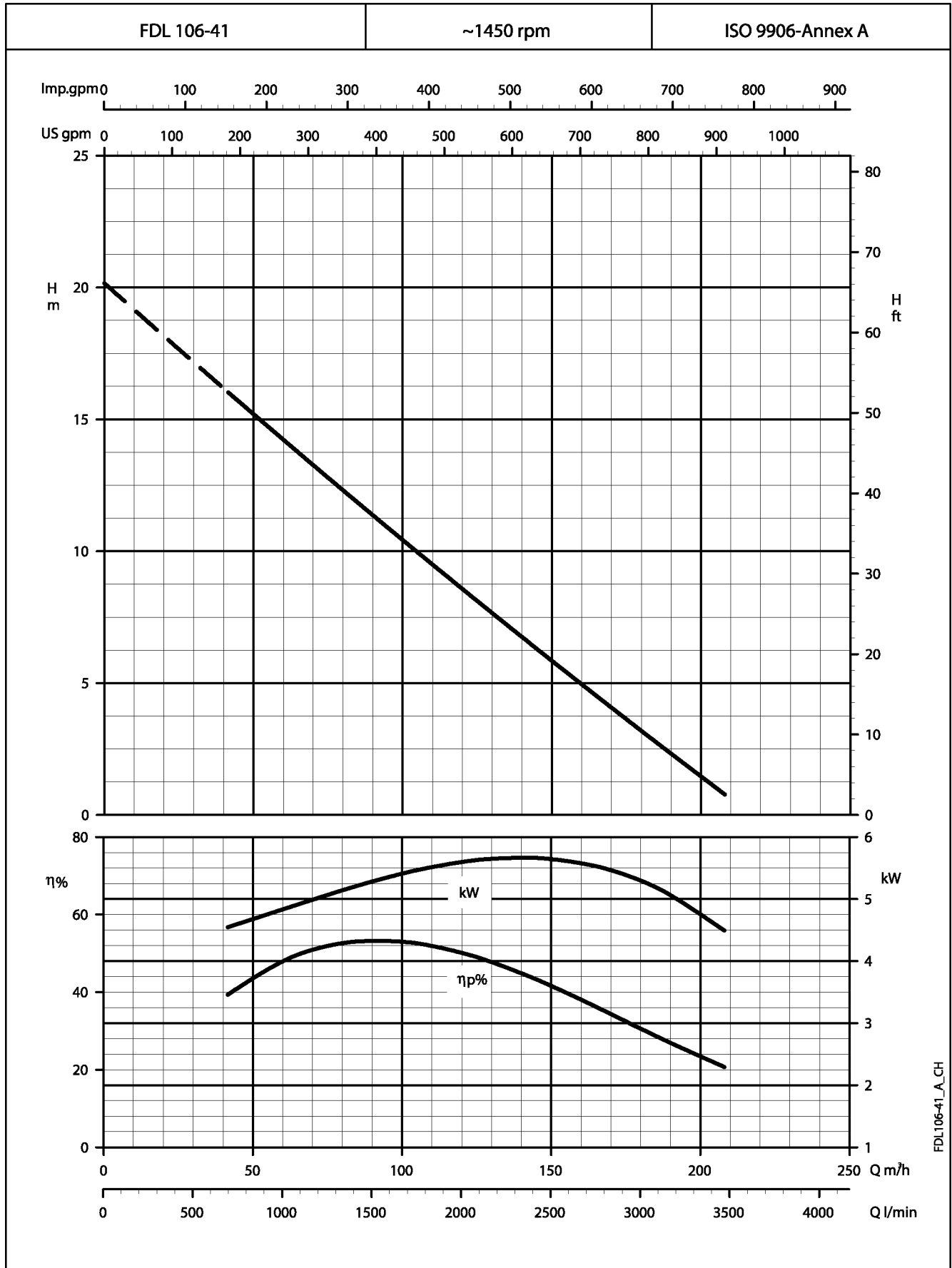

These performances are valid for liquids with density $\rho = 1.0 \text{ kg/dm}^3$ and kinematic viscosity $\gamma = 1 \text{ mm}^2/\text{s}$.

**FDL SERIES
OPERATING CHARACTERISTICS AT 1450 rpm 50 Hz**

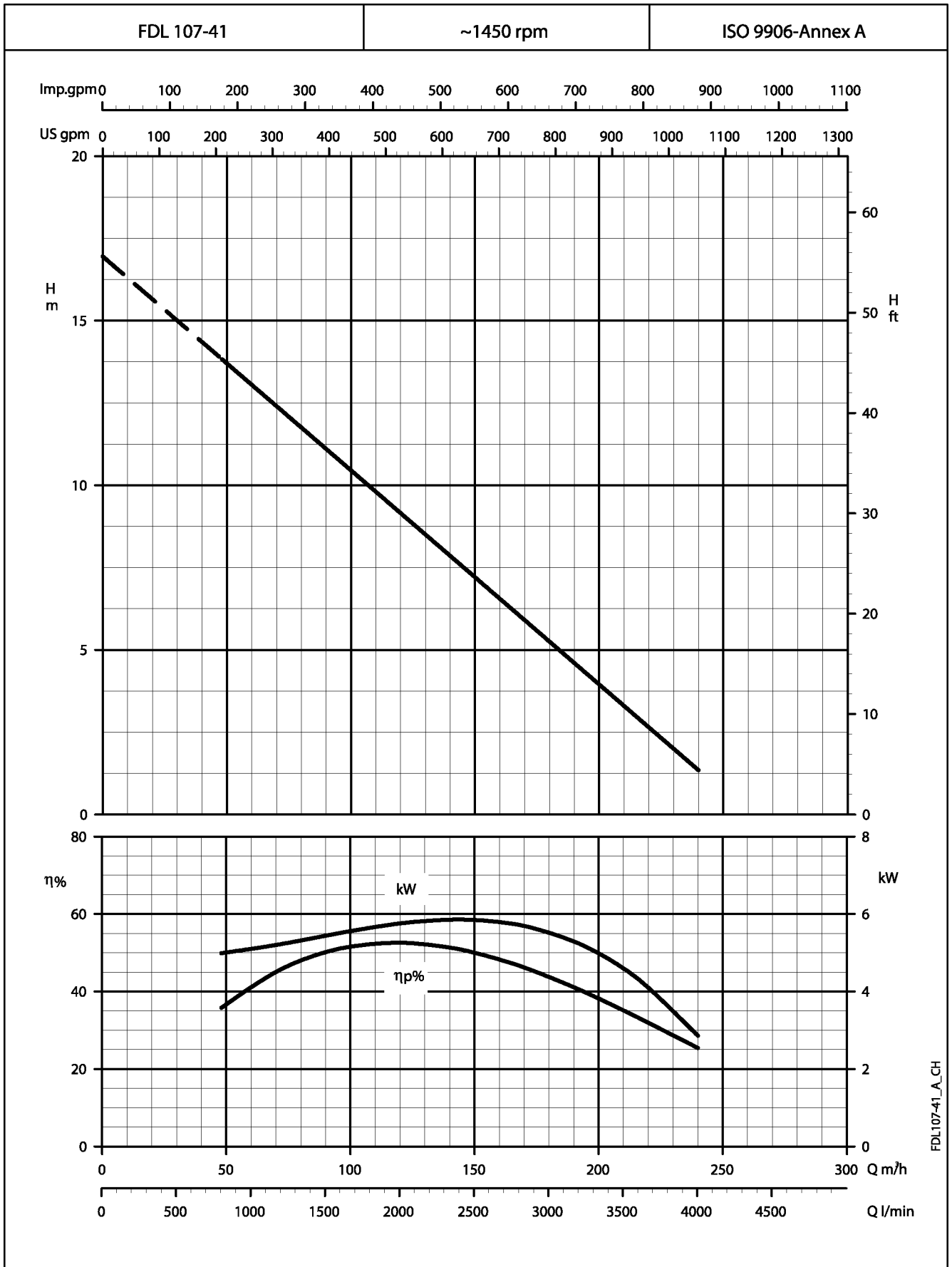

FDL107-41_A_CH

These performances are valid for liquids with density $\rho = 1.0 \text{ kg/dm}^3$ and kinematic viscosity $\gamma = 1 \text{ mm}^2/\text{s}$.

**FDL SERIES
OPERATING CHARACTERISTICS AT 1450 rpm 50 Hz**

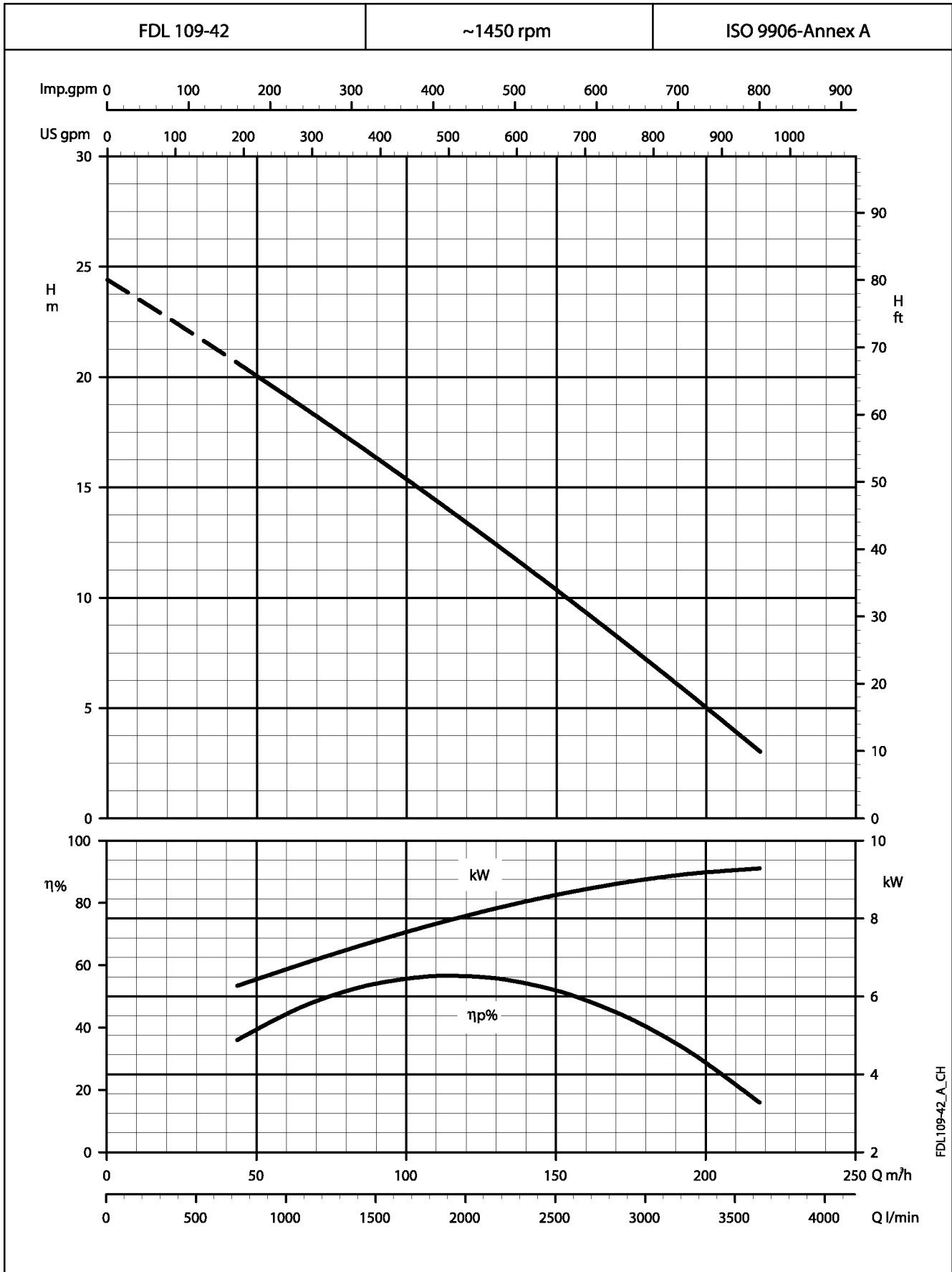

These performances are valid for liquids with density $\rho = 1.0 \text{ kg/dm}^3$ and kinematic viscosity $\nu = 1 \text{ mm}^2/\text{s}$.

**FDL SERIES
OPERATING CHARACTERISTICS AT 1450 rpm 50 Hz**

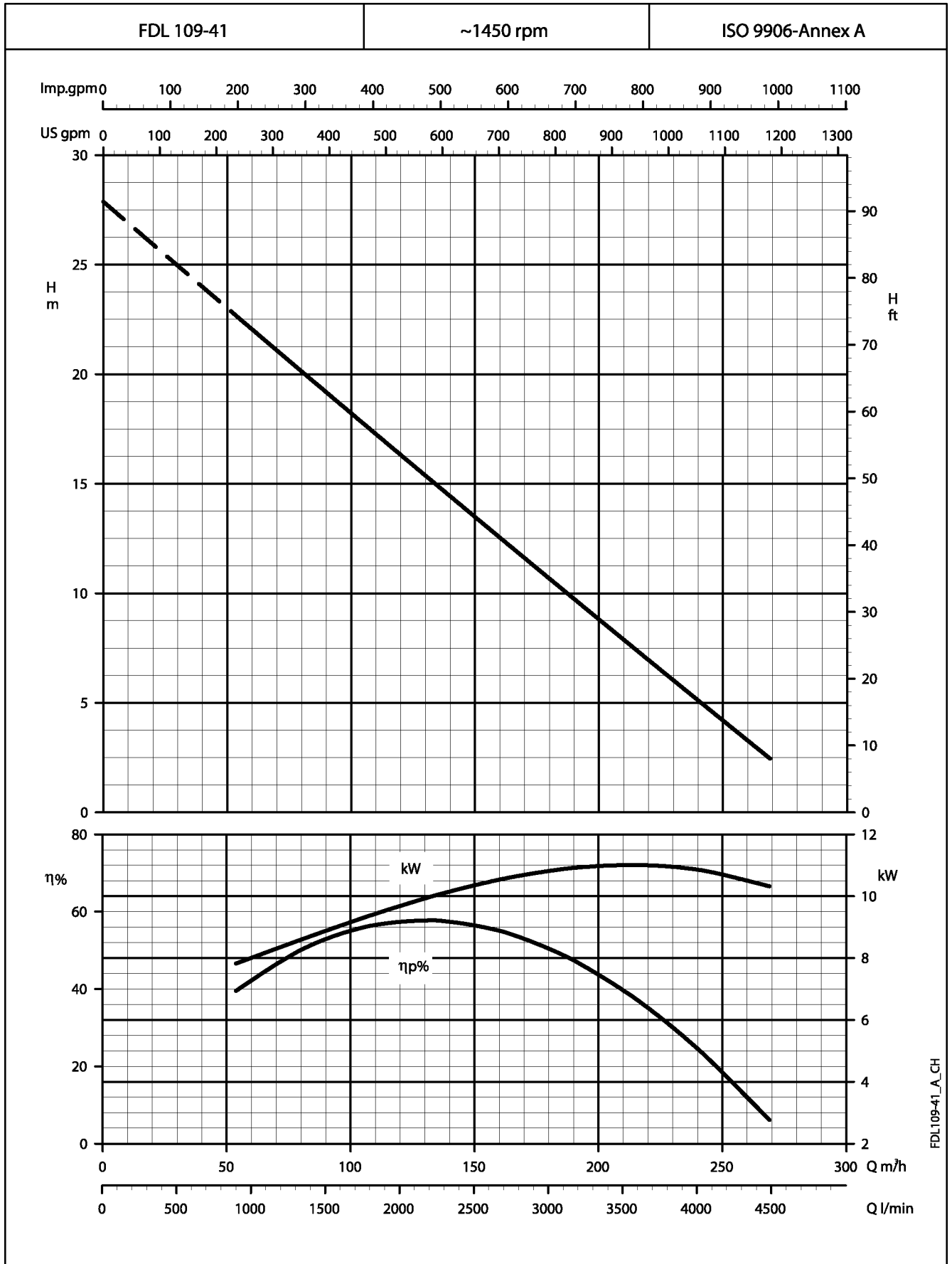

These performances are valid for liquids with density $\rho = 1.0 \text{ kg/dm}^3$ and kinematic viscosity $\gamma = 1 \text{ mm}^2/\text{s}$.

**FDL SERIES
OPERATING CHARACTERISTICS AT 1450 rpm 50 Hz**

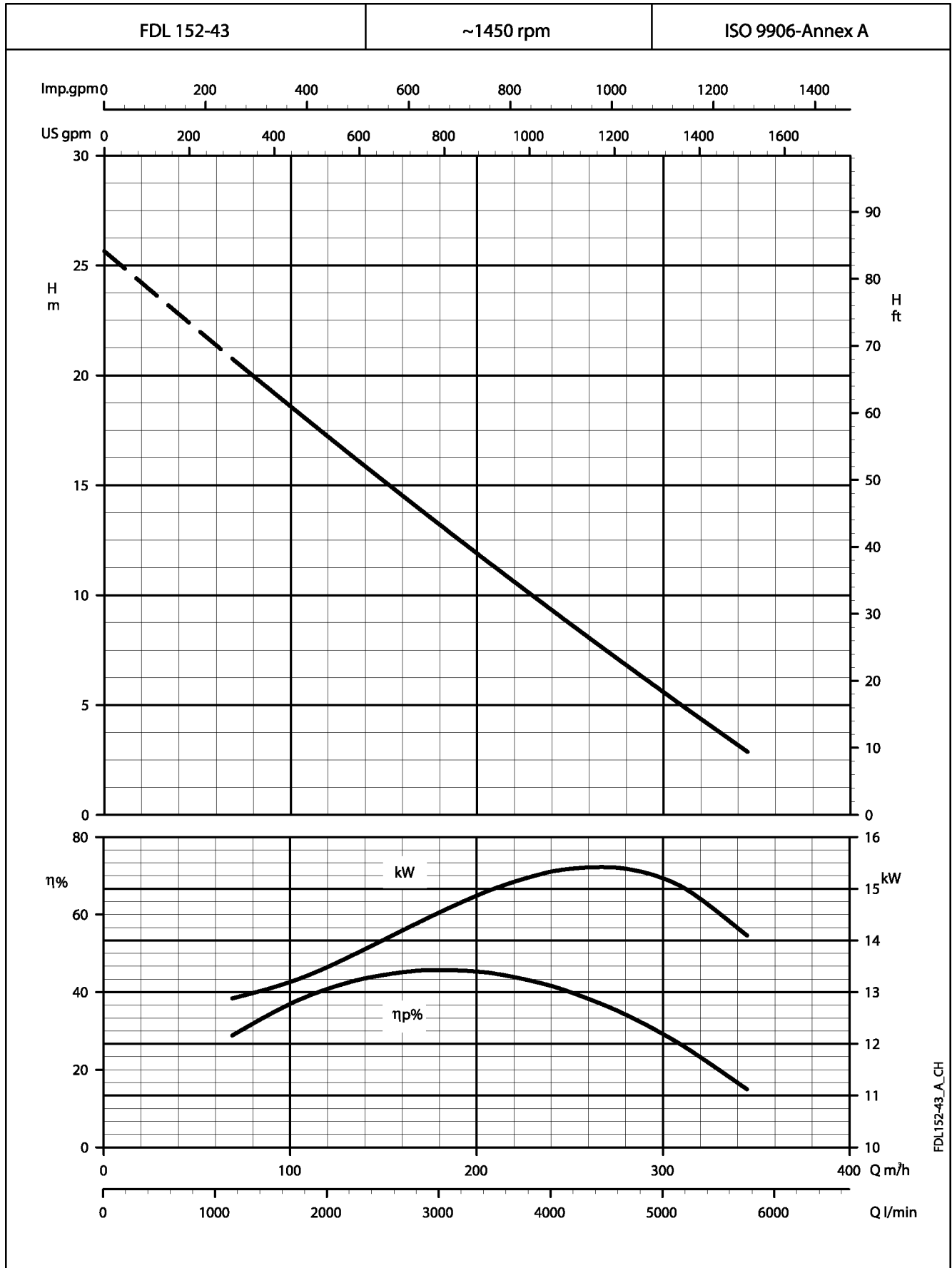

These performances are valid for liquids with density $\rho = 1.0 \text{ kg/dm}^3$ and kinematic viscosity $\nu = 1 \text{ mm}^2/\text{s}$.

**FDL SERIES
OPERATING CHARACTERISTICS AT 1450 rpm 50 Hz**

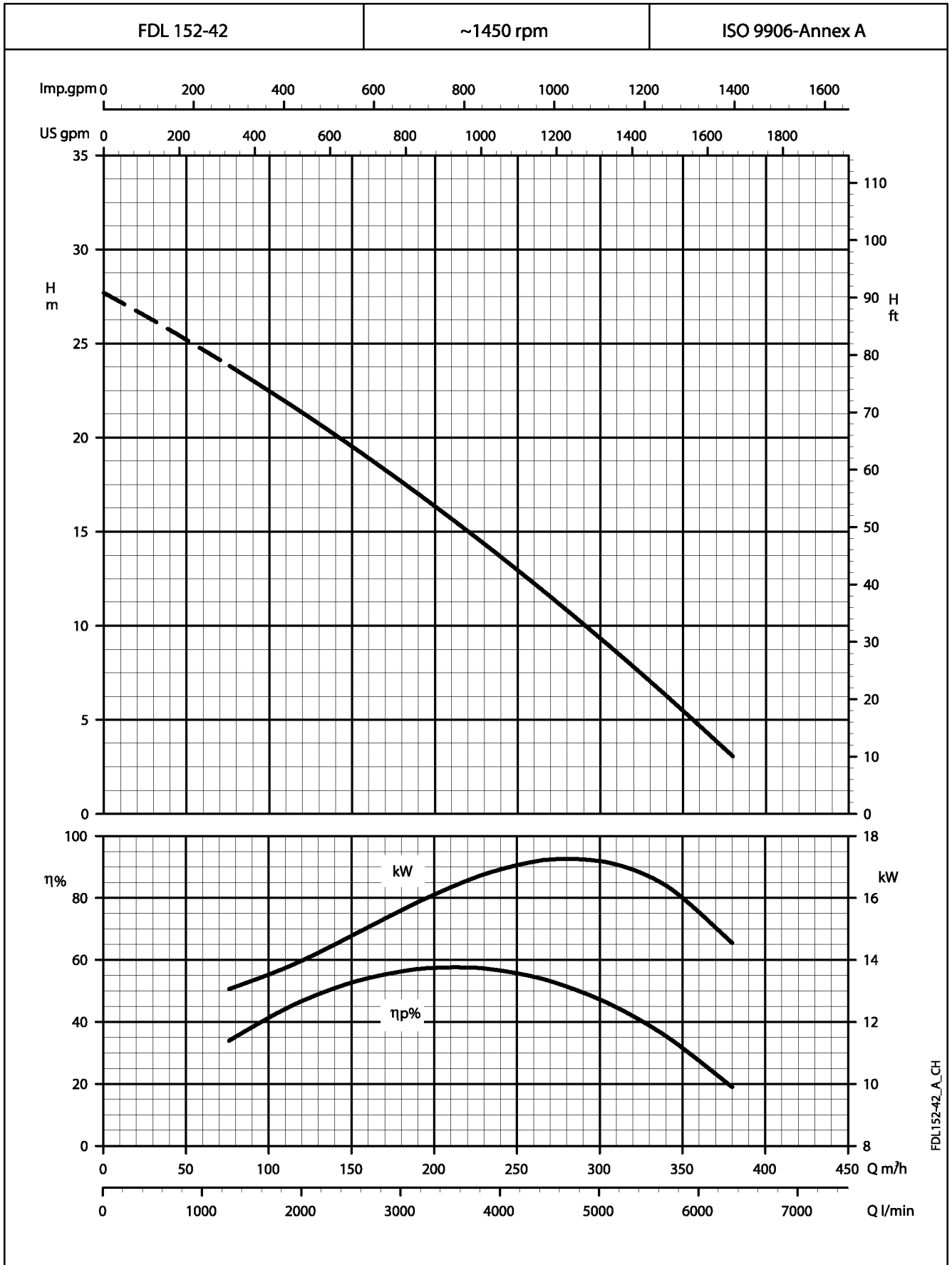

These performances are valid for liquids with density $\rho = 1.0 \text{ kg/dm}^3$ and kinematic viscosity $\gamma = 1 \text{ mm}^2/\text{s}$.

**FDL SERIES
OPERATING CHARACTERISTICS AT 1450 rpm 50 Hz**

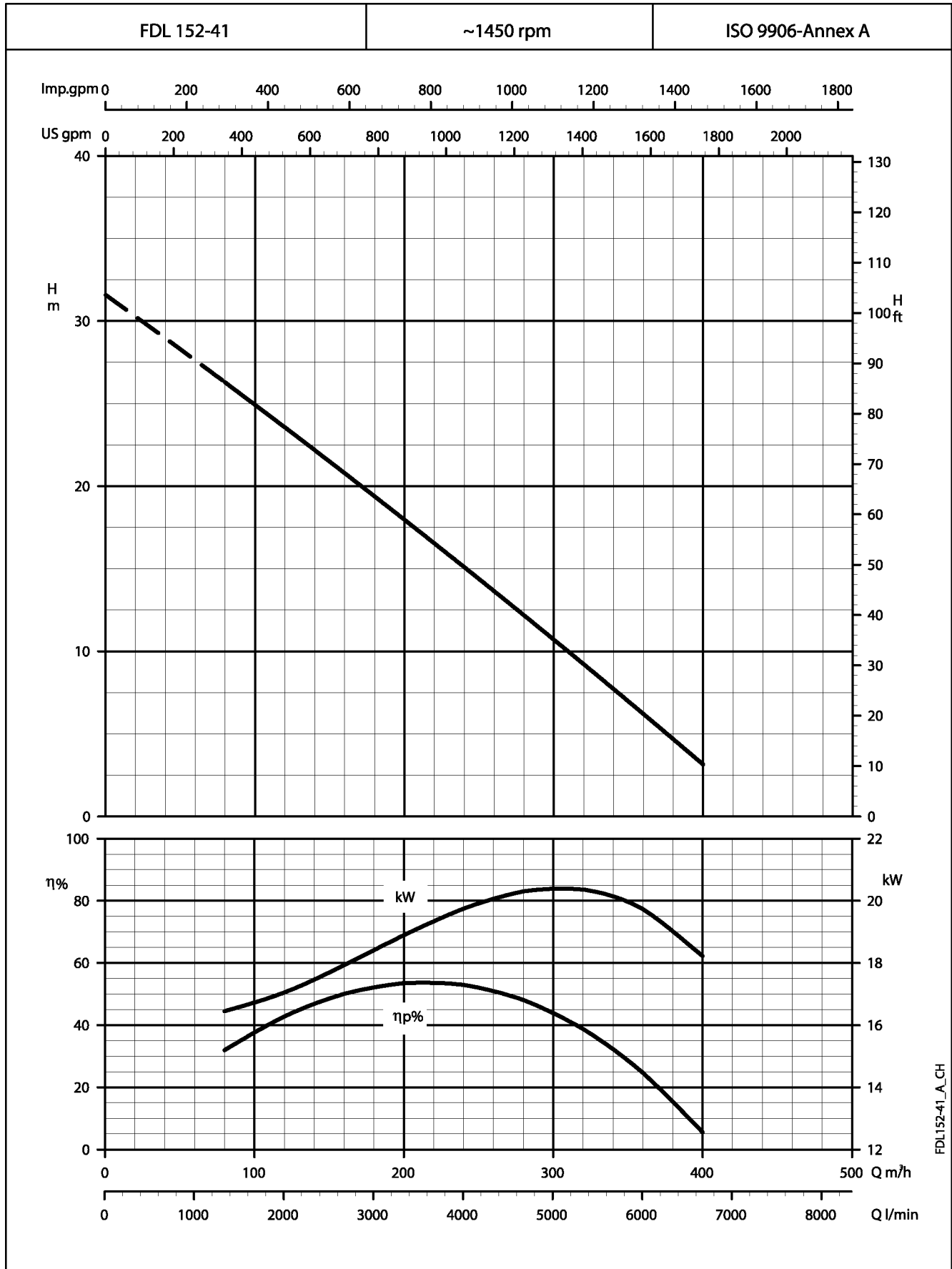

These performances are valid for liquids with density $\rho = 1.0 \text{ kg/dm}^3$ and kinematic viscosity $\nu = 1 \text{ mm}^2/\text{s}$.

**FDL SERIES
OPERATING CHARACTERISTICS AT 2850 rpm 50 Hz**

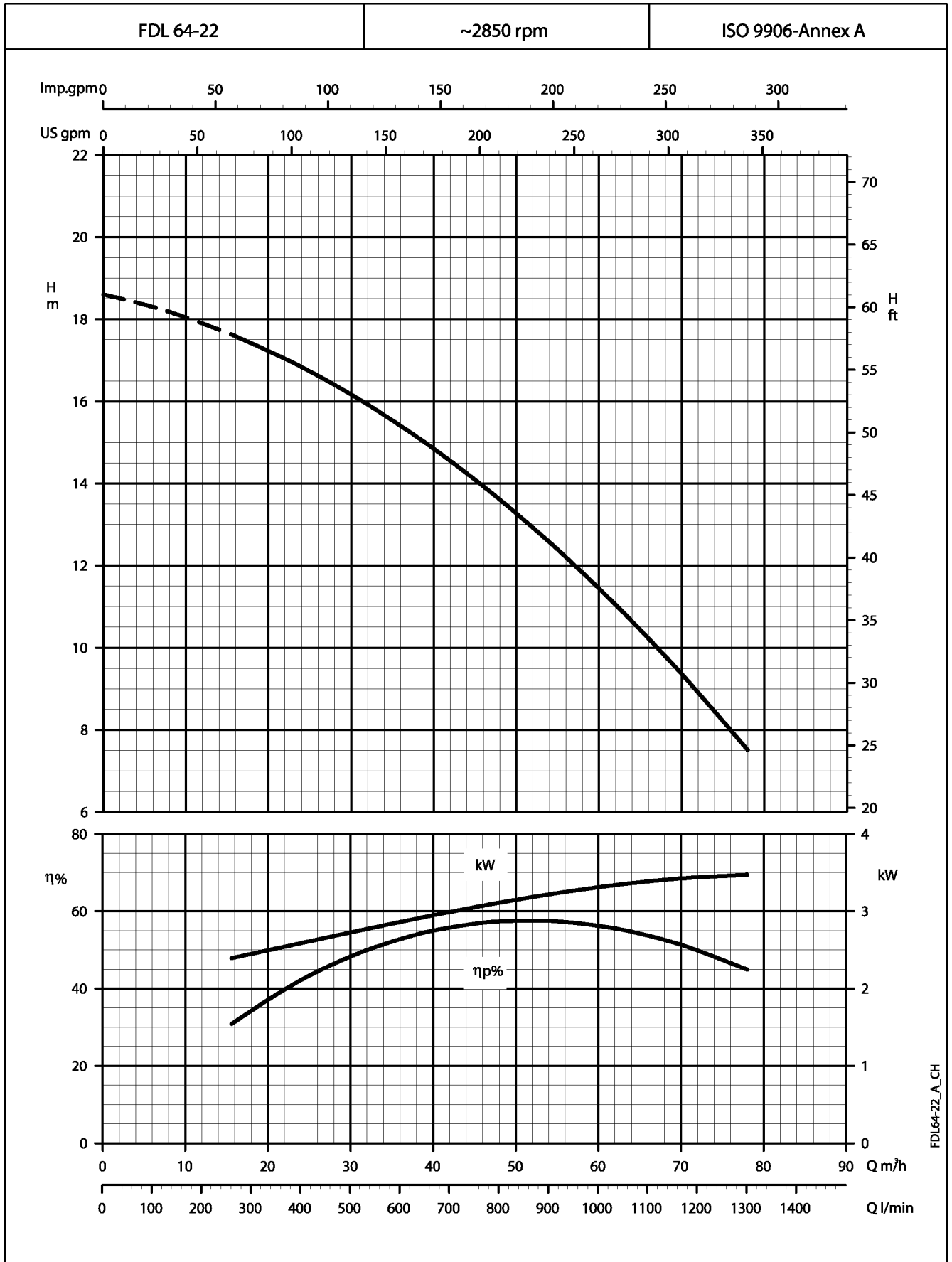

These performances are valid for liquids with density $\rho = 1.0 \text{ kg/dm}^3$ and kinematic viscosity $\gamma = 1 \text{ mm}^2/\text{s}$.

**FDL SERIES
OPERATING CHARACTERISTICS AT 2850 rpm 50 Hz**

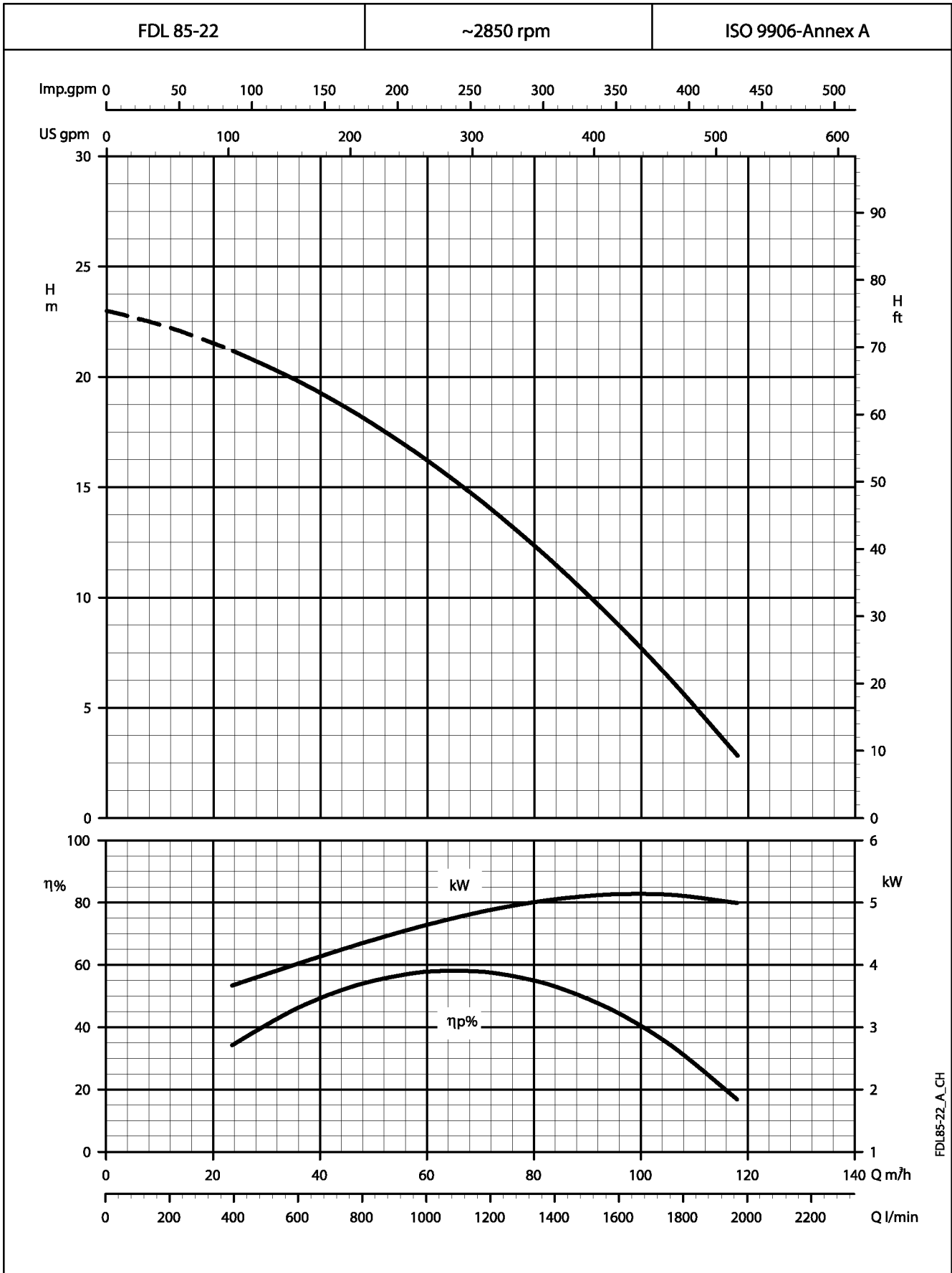

FDL85-22_A_CH

These performances are valid for liquids with density $\rho = 1.0 \text{ kg/dm}^3$ and kinematic viscosity $\gamma = 1 \text{ mm}^2/\text{s}$.

**FDL SERIES
OPERATING CHARACTERISTICS AT 2850 rpm 50 Hz**

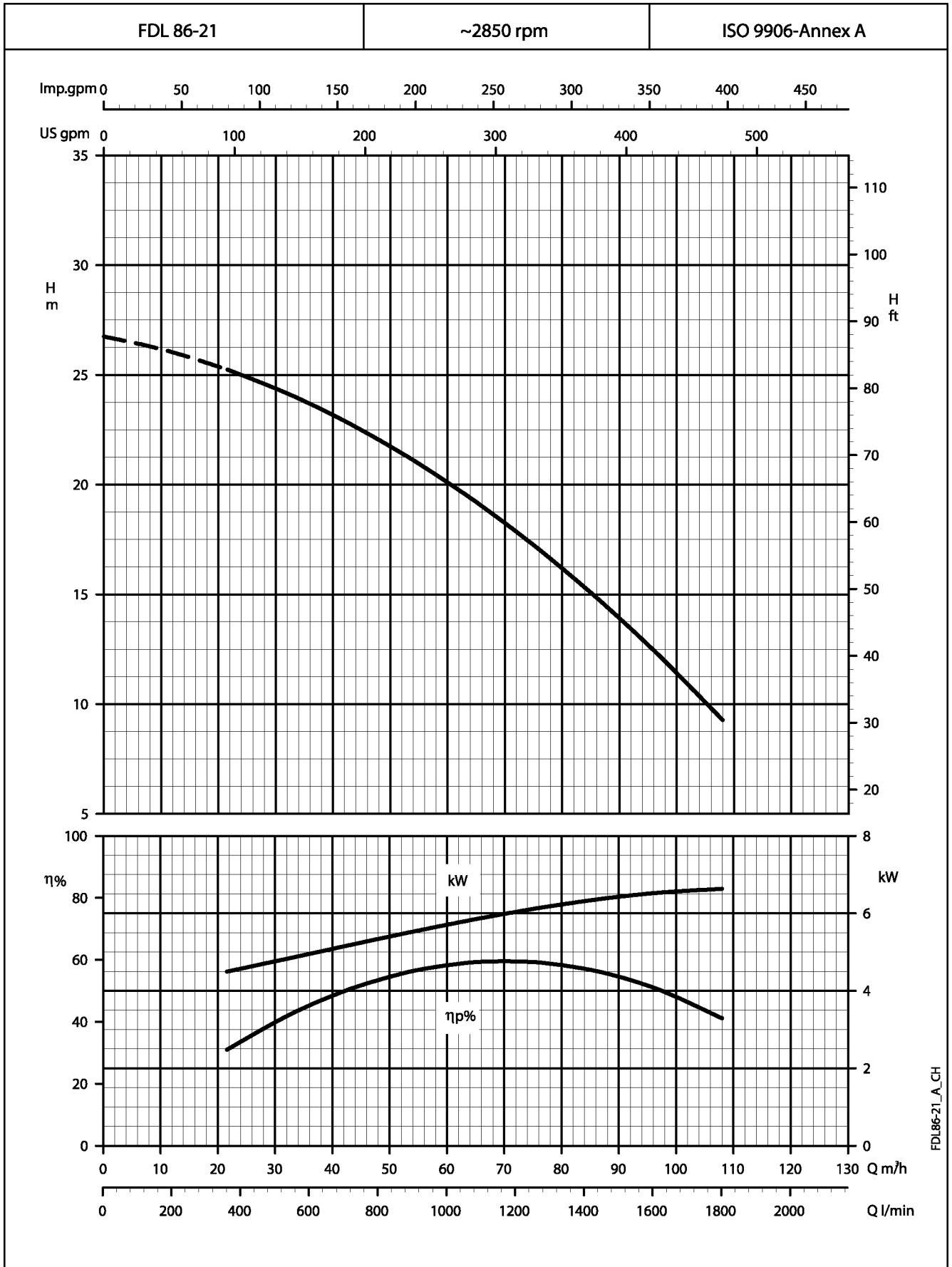

These performances are valid for liquids with density $\rho = 1.0 \text{ kg/dm}^3$ and kinematic viscosity $\gamma = 1 \text{ mm}^2/\text{s}$.

**FDL SERIES
OPERATING CHARACTERISTICS AT 2850 rpm 50 Hz**

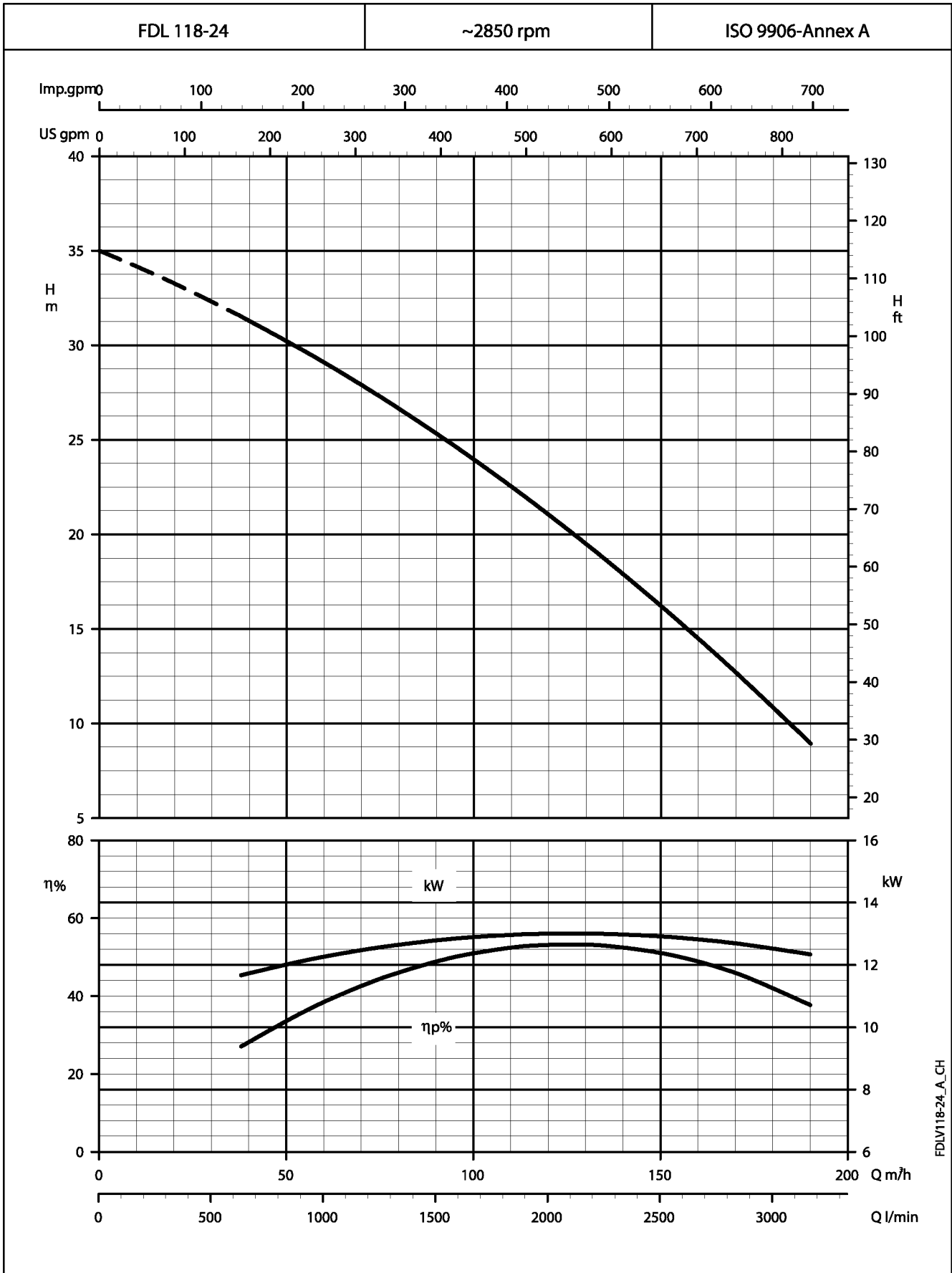

These performances are valid for liquids with density $\rho = 1.0 \text{ kg/dm}^3$ and kinematic viscosity $\gamma = 1 \text{ mm}^2/\text{s}$.

**FDL SERIES
OPERATING CHARACTERISTICS AT 2850 rpm 50 Hz**

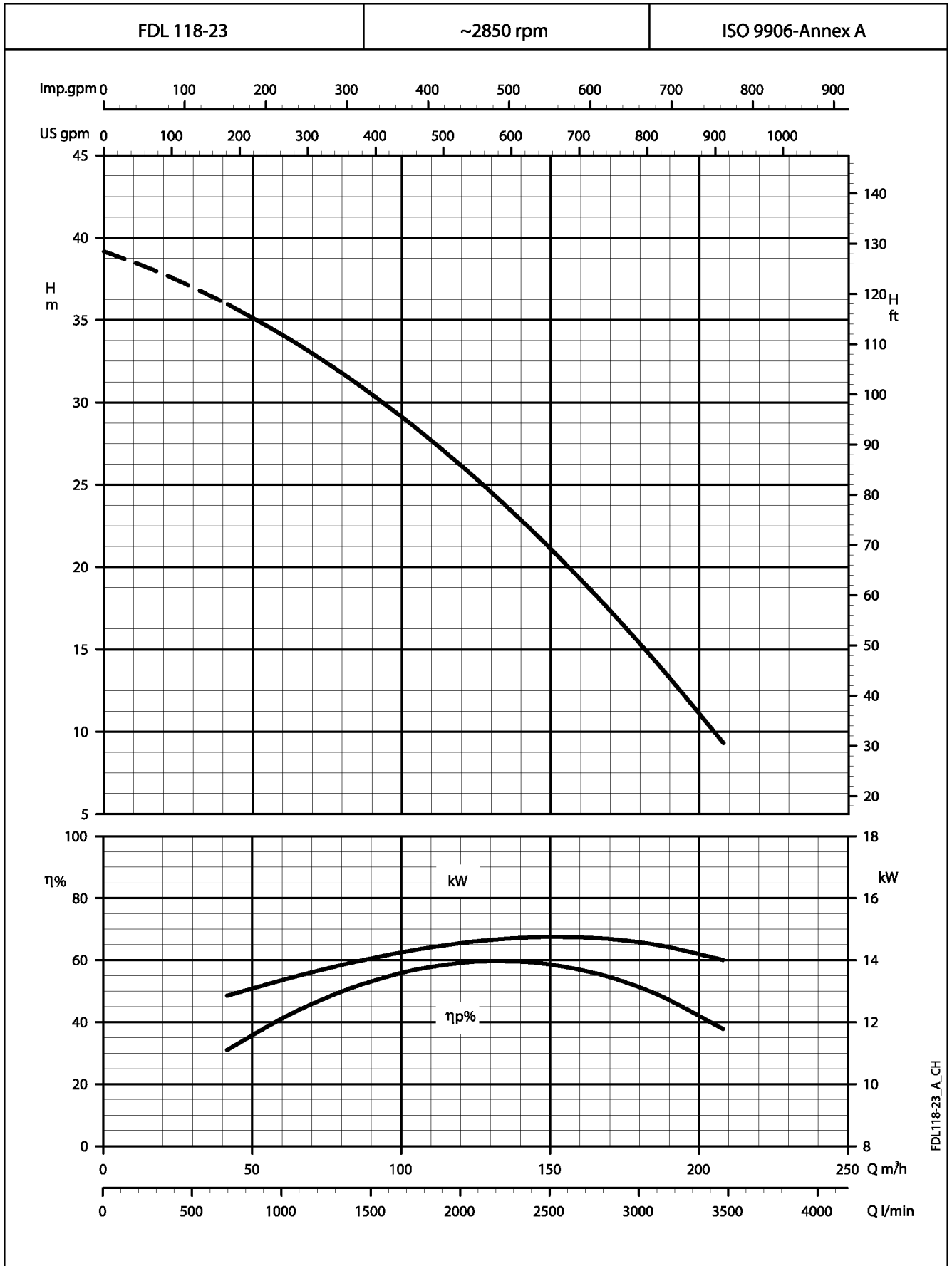

FDL118-23_A_CH

These performances are valid for liquids with density $\rho = 1.0 \text{ kg/dm}^3$ and kinematic viscosity $\gamma = 1 \text{ mm}^2/\text{s}$.

**FDL SERIES
OPERATING CHARACTERISTICS AT 2850 rpm 50 Hz**

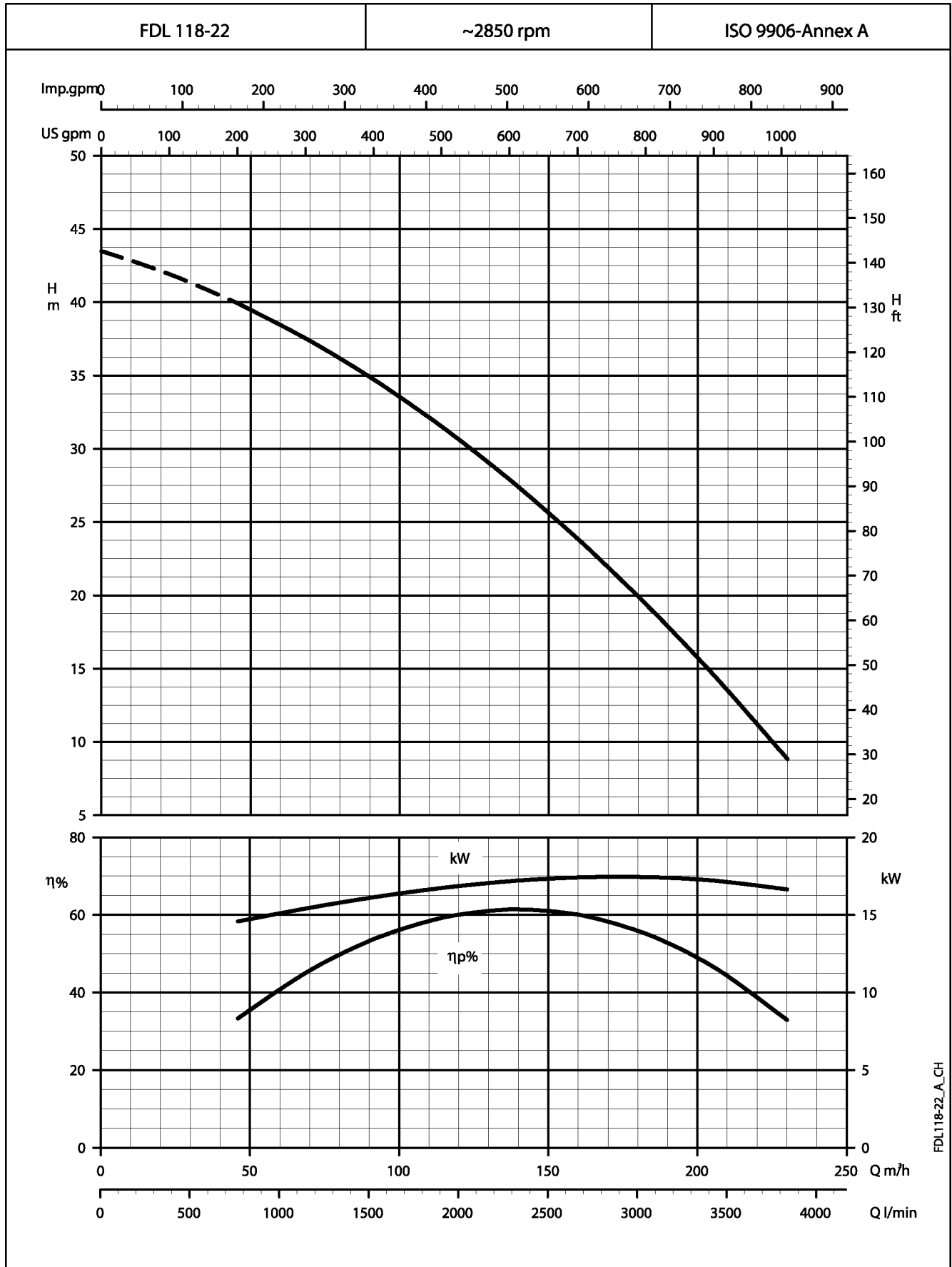

These performances are valid for liquids with density $\rho = 1.0 \text{ kg/dm}^3$ and kinematic viscosity $\nu = 1 \text{ mm}^2/\text{s}$.

**FDL SERIES
OPERATING CHARACTERISTICS AT 2850 rpm 50 Hz**

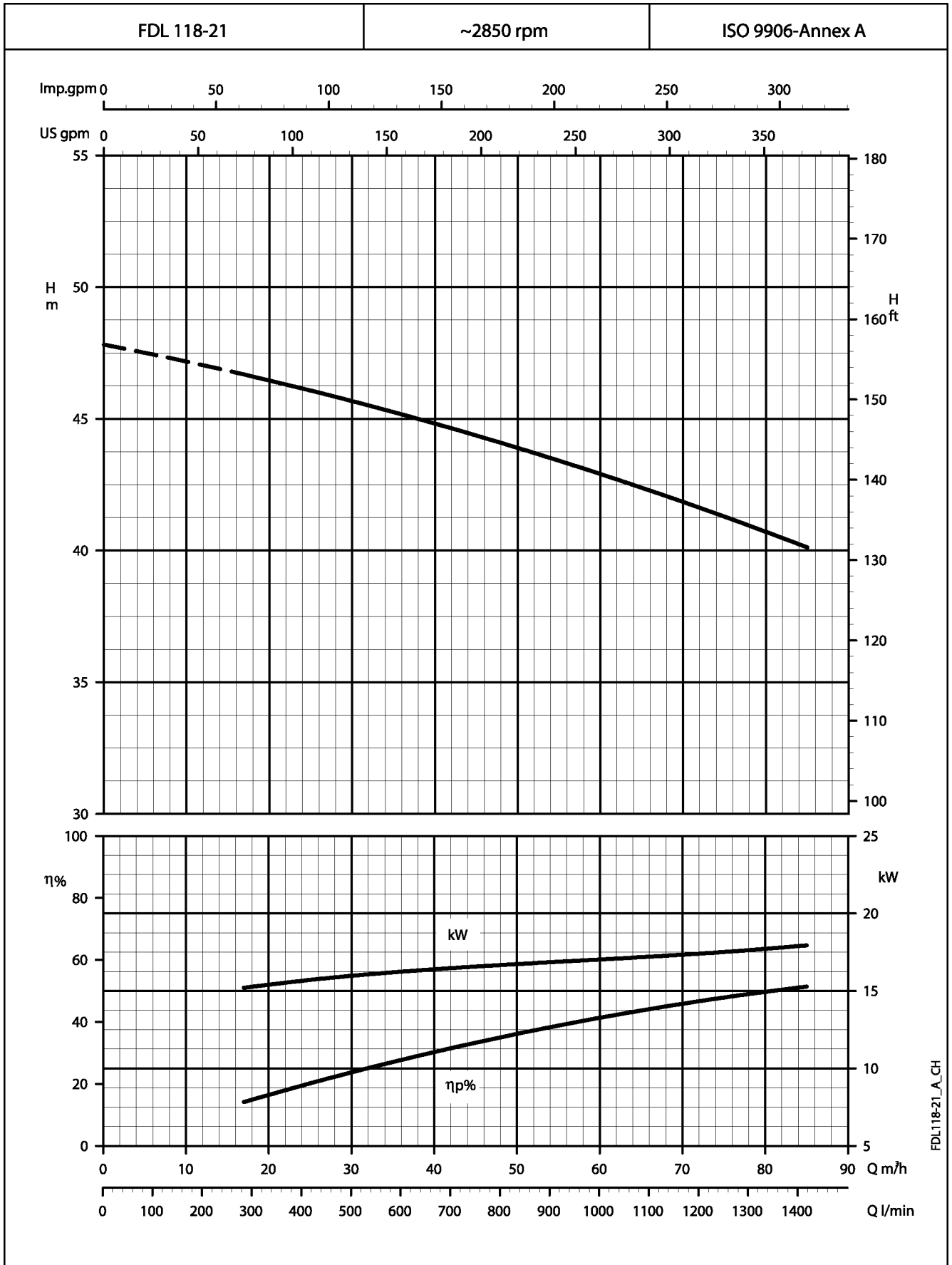

These performances are valid for liquids with density $\rho = 1.0 \text{ kg/dm}^3$ and kinematic viscosity $\gamma = 1 \text{ mm}^2/\text{s}$.

**FDL SERIES
OPERATING CHARACTERISTICS AT 1450 rpm 50 Hz**

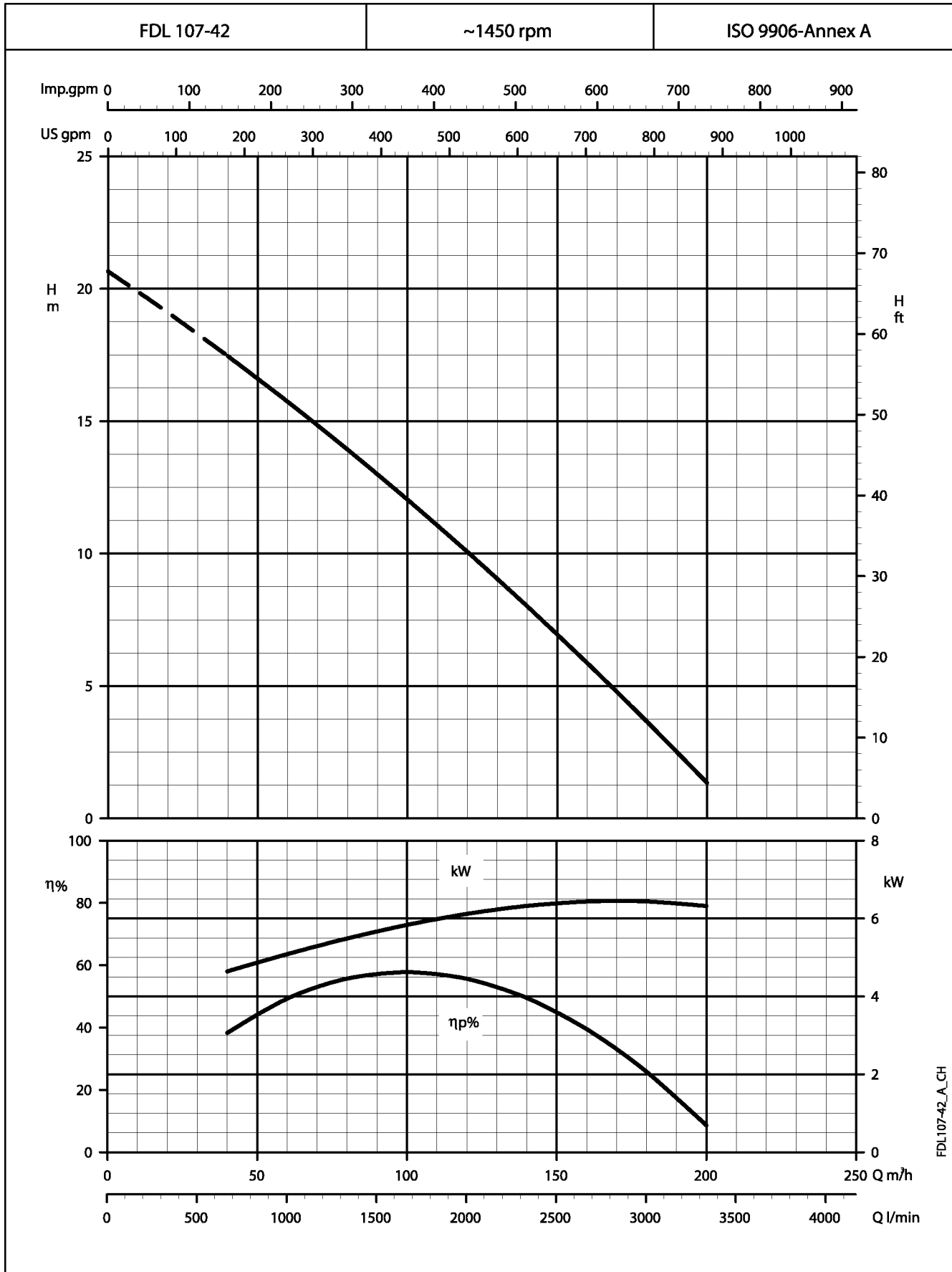

These performances are valid for liquids with density $\rho = 1.0 \text{ kg/dm}^3$ and kinematic viscosity $\gamma = 1 \text{ mm}^2/\text{s}$.

**FDL SERIES
OPERATING CHARACTERISTICS AT 1450 rpm 50 Hz**

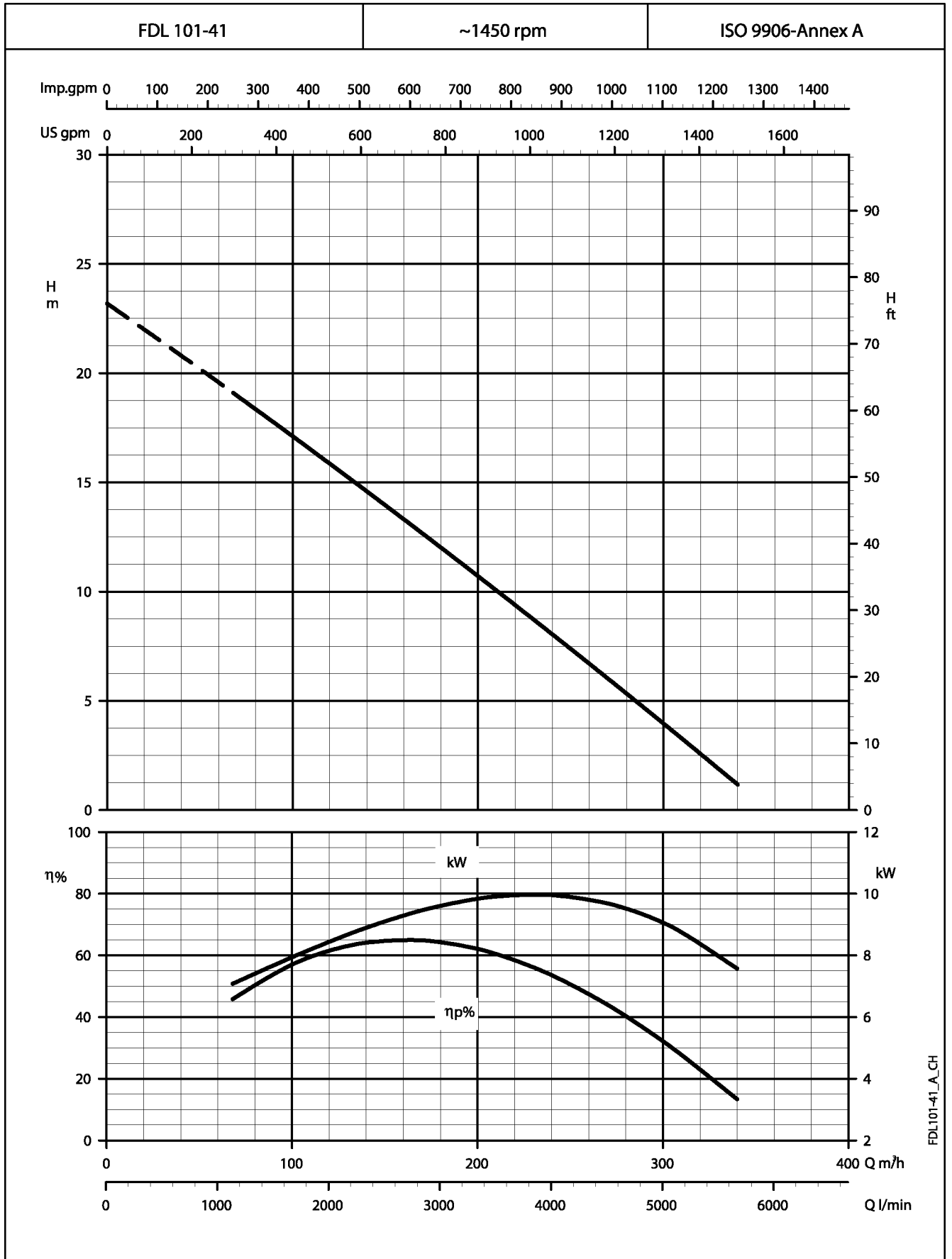

These performances are valid for liquids with density $\rho = 1.0 \text{ kg/dm}^3$ and kinematic viscosity $\gamma = 1 \text{ mm}^2/\text{s}$.

**FDL SERIES
OPERATING CHARACTERISTICS AT 1450 rpm 50 Hz**

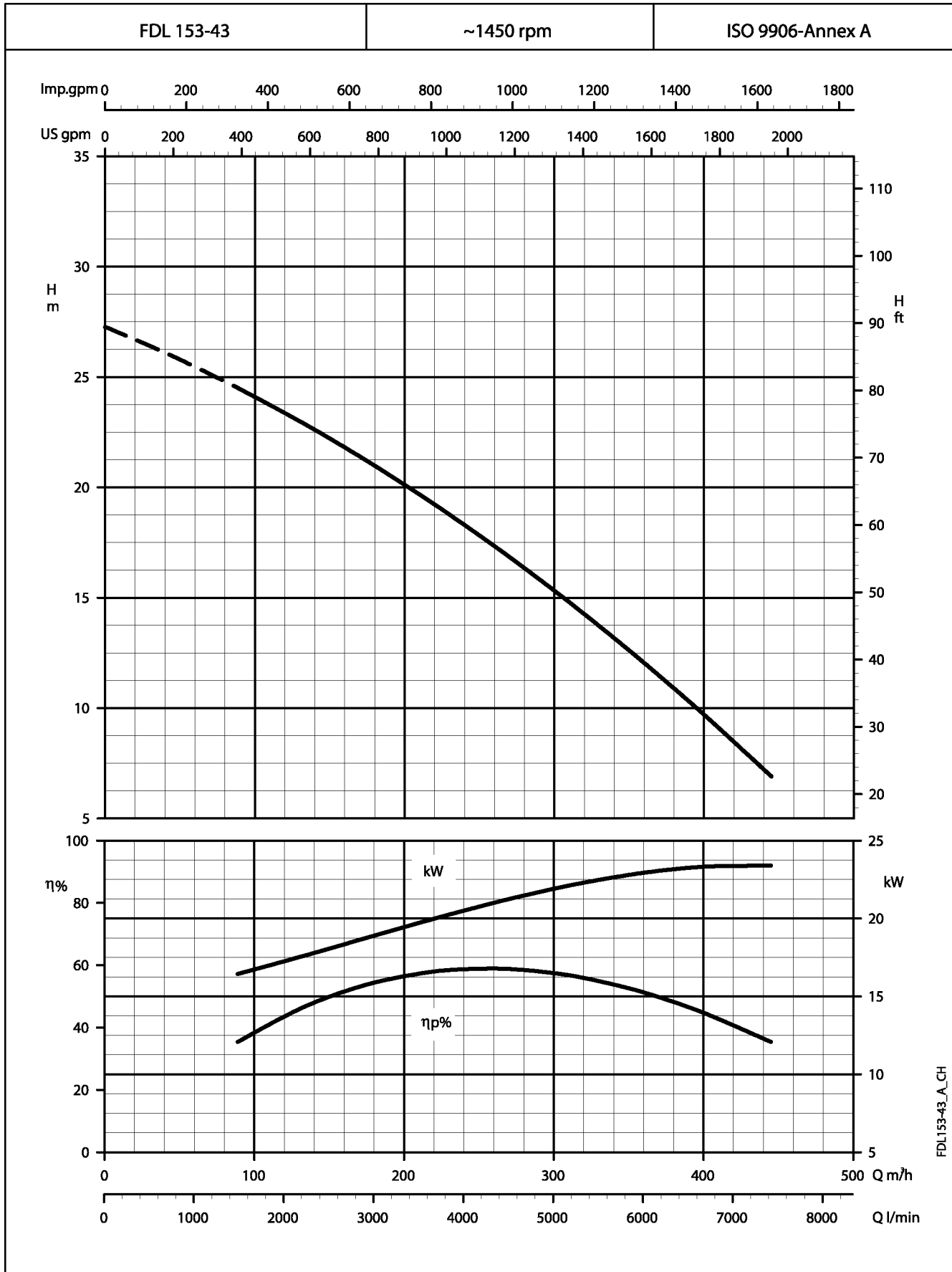

These performances are valid for liquids with density $\rho = 1.0 \text{ kg/dm}^3$ and kinematic viscosity $\gamma = 1 \text{ mm}^2/\text{s}$.

**FDL SERIES
OPERATING CHARACTERISTICS AT 1450 rpm 50 Hz**

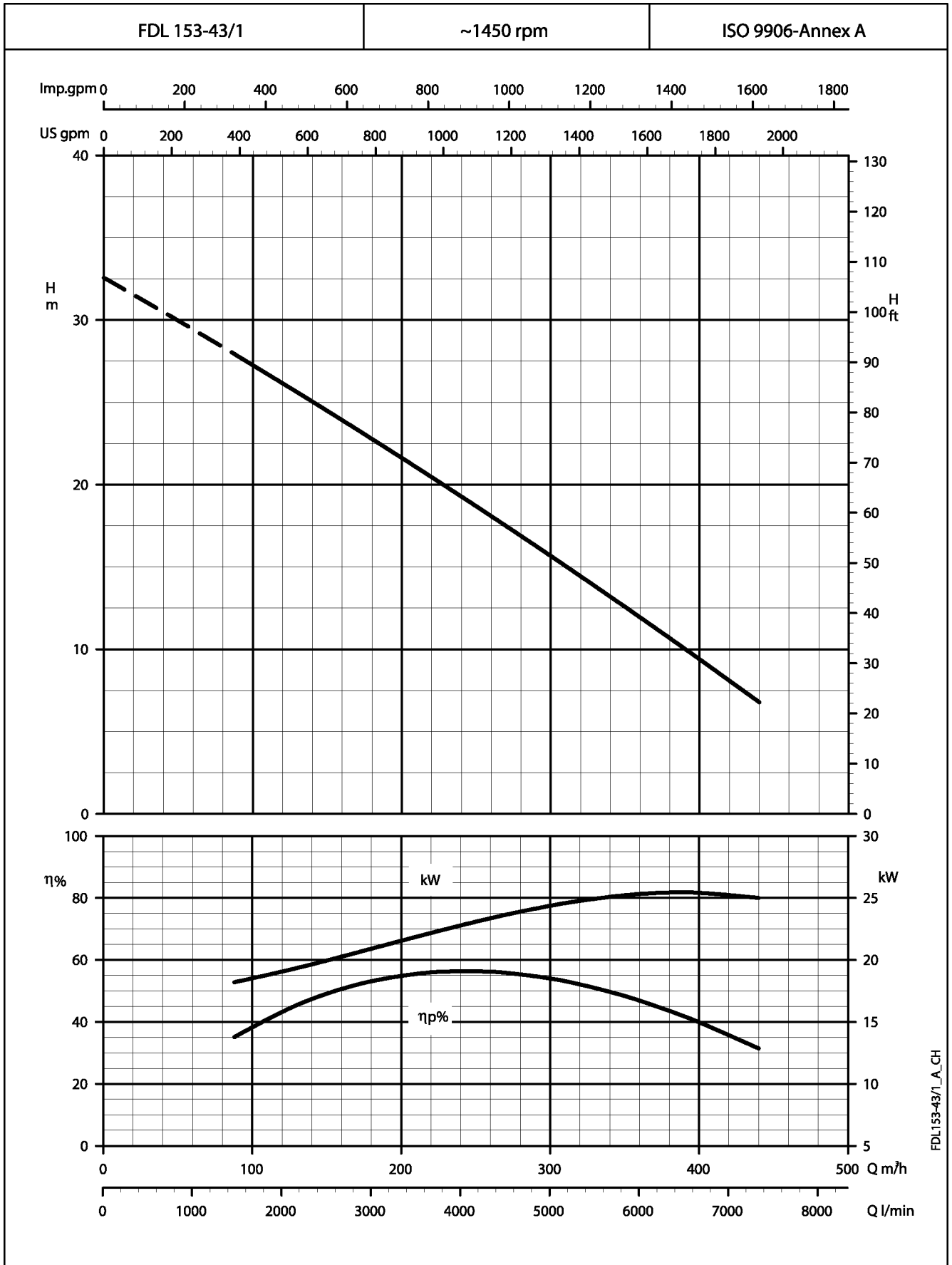

These performances are valid for liquids with density $\rho = 1.0 \text{ kg/dm}^3$ and kinematic viscosity $\gamma = 1 \text{ mm}^2/\text{s}$.

**FDL SERIES
OPERATING CHARACTERISTICS AT 1450 rpm 50 Hz**

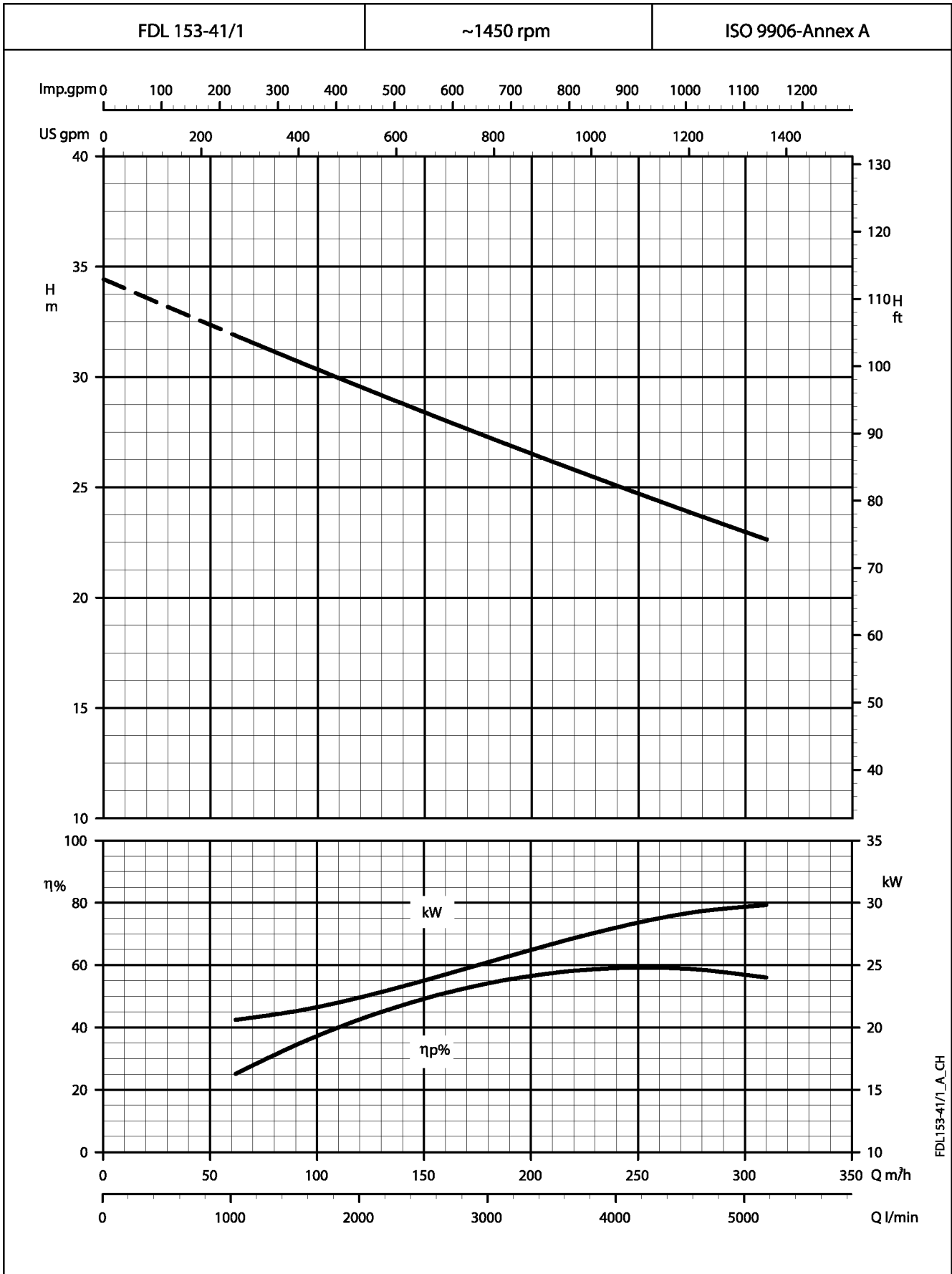

These performances are valid for liquids with density $\rho = 1.0 \text{ kg/dm}^3$ and kinematic viscosity $\nu = 1 \text{ mm}^2/\text{s}$.

**FDL SERIES
OPERATING CHARACTERISTICS AT 1450 rpm 50 Hz**

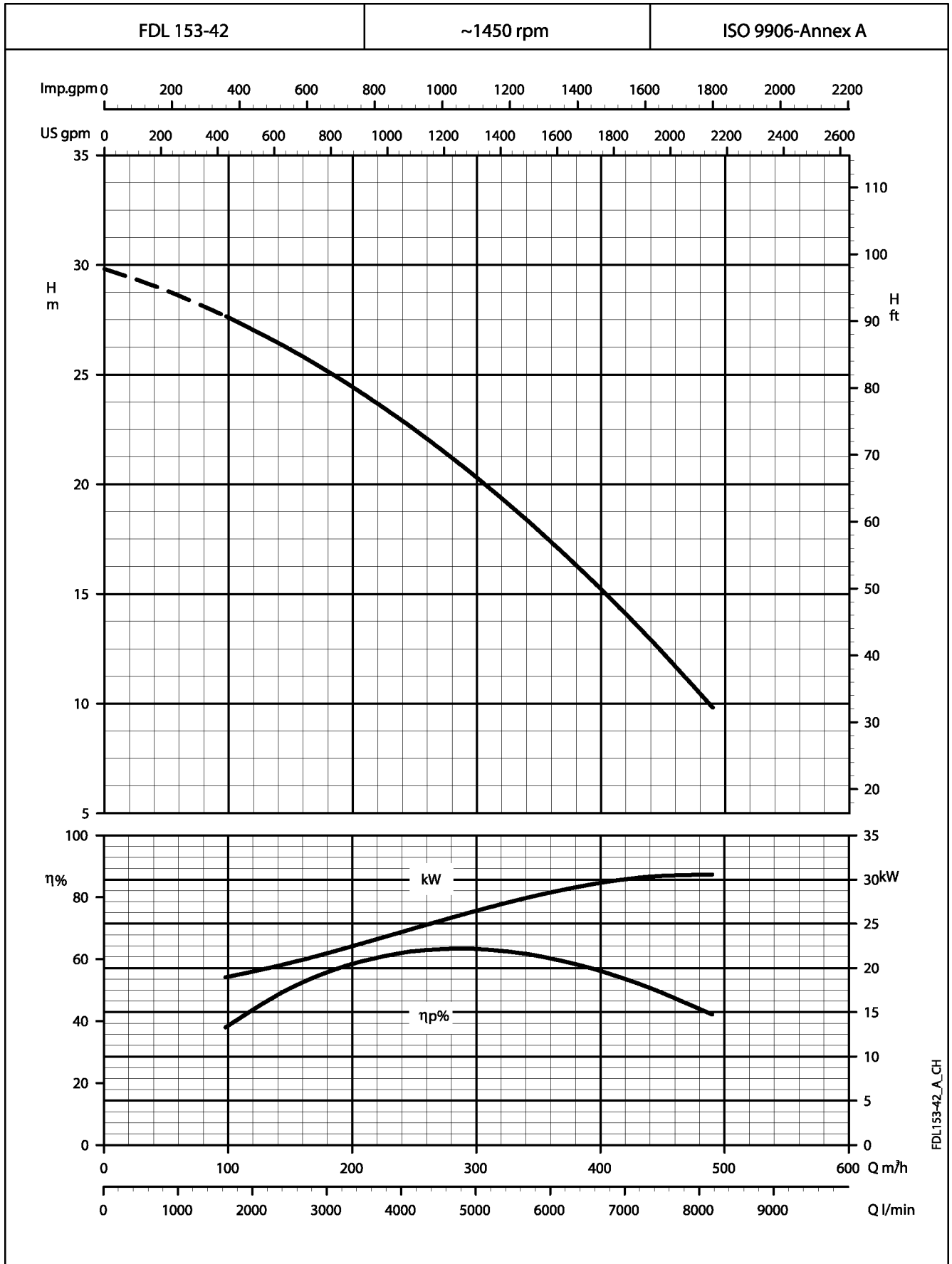

These performances are valid for liquids with density $\rho = 1.0 \text{ kg/dm}^3$ and kinematic viscosity $\gamma = 1 \text{ mm}^2/\text{s}$.

**FDL SERIES
OPERATING CHARACTERISTICS AT 1450 rpm 50 Hz**

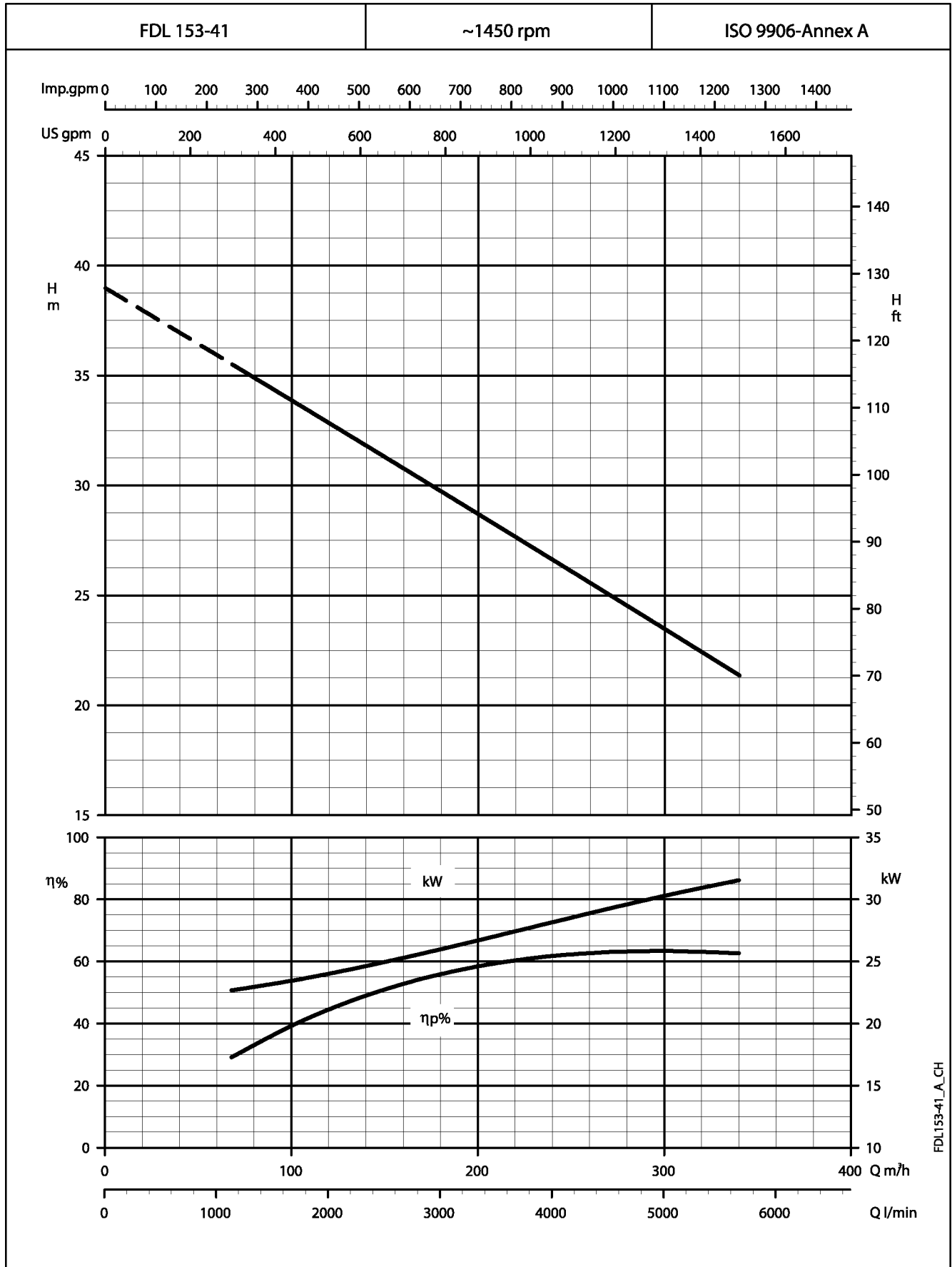

These performances are valid for liquids with density $\rho = 1.0 \text{ kg/dm}^3$ and kinematic viscosity $\nu = 1 \text{ mm}^2/\text{s}$.

**FDL SERIES
OPERATING CHARACTERISTICS AT 1450 rpm 50 Hz**

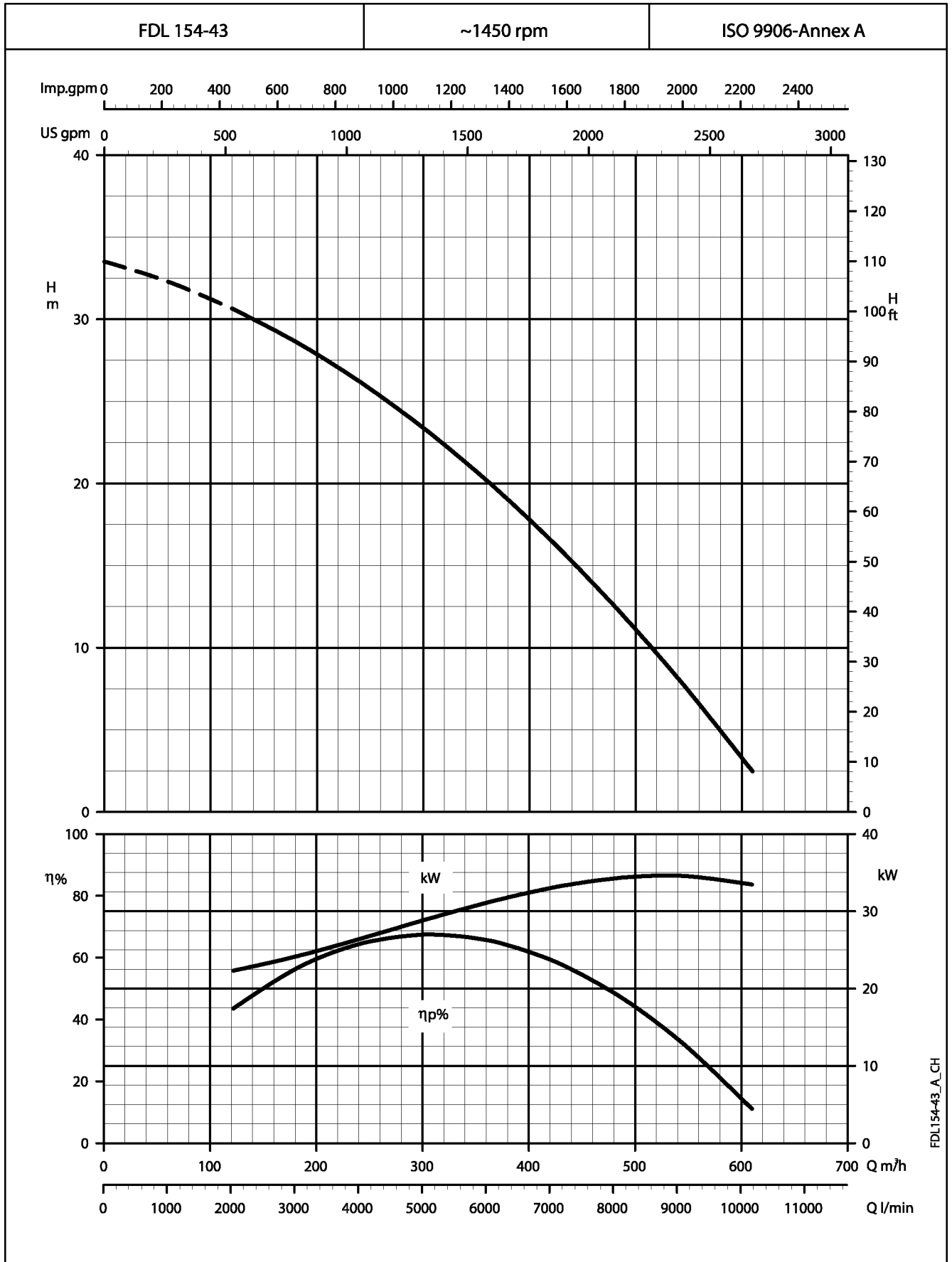

These performances are valid for liquids with density $\rho = 1.0 \text{ kg/dm}^3$ and kinematic viscosity $\gamma = 1 \text{ mm}^2/\text{s}$.

**FDL SERIES
OPERATING CHARACTERISTICS AT 1450 rpm 50 Hz**

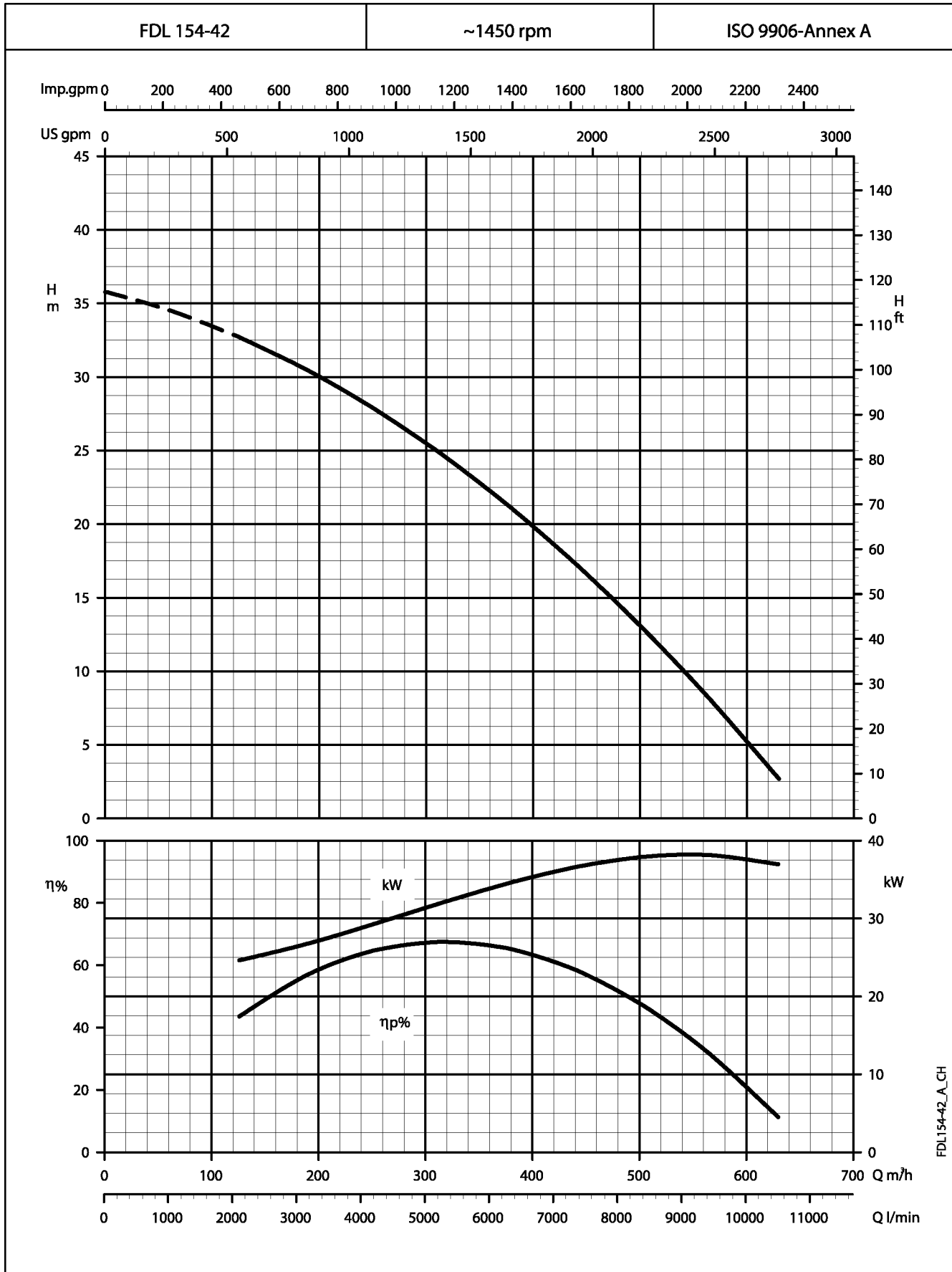

These performances are valid for liquids with density $\rho = 1.0 \text{ kg/dm}^3$ and kinematic viscosity $\nu = 1 \text{ mm}^2/\text{s}$.

**FDL SERIES
OPERATING CHARACTERISTICS AT 1450 rpm 50 Hz**

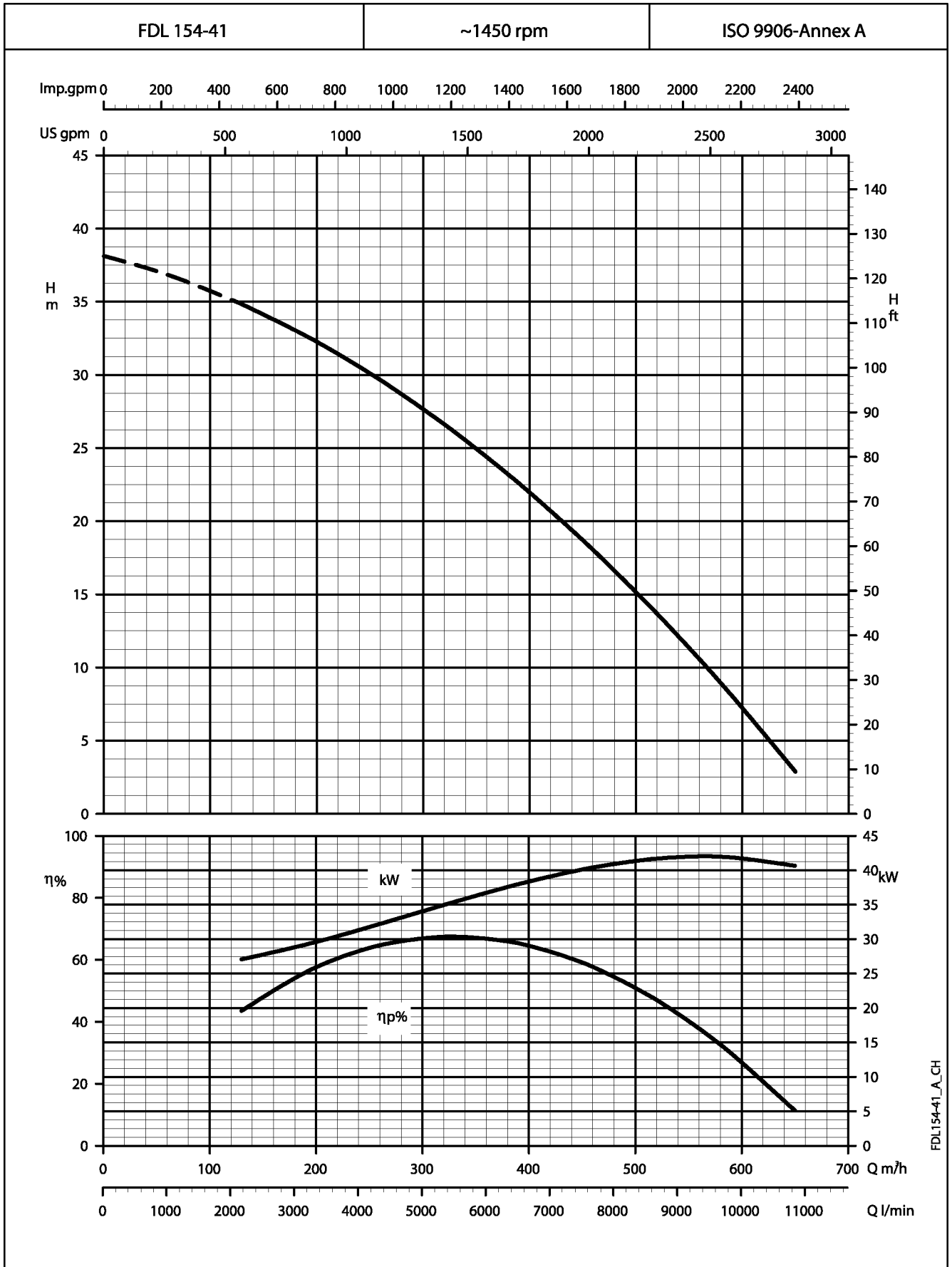

These performances are valid for liquids with density $\rho = 1.0 \text{ kg/dm}^3$ and kinematic viscosity $\gamma = 1 \text{ mm}^2/\text{s}$.

**FDL SERIES
OPERATING CHARACTERISTICS AT 2850 rpm 50 Hz**

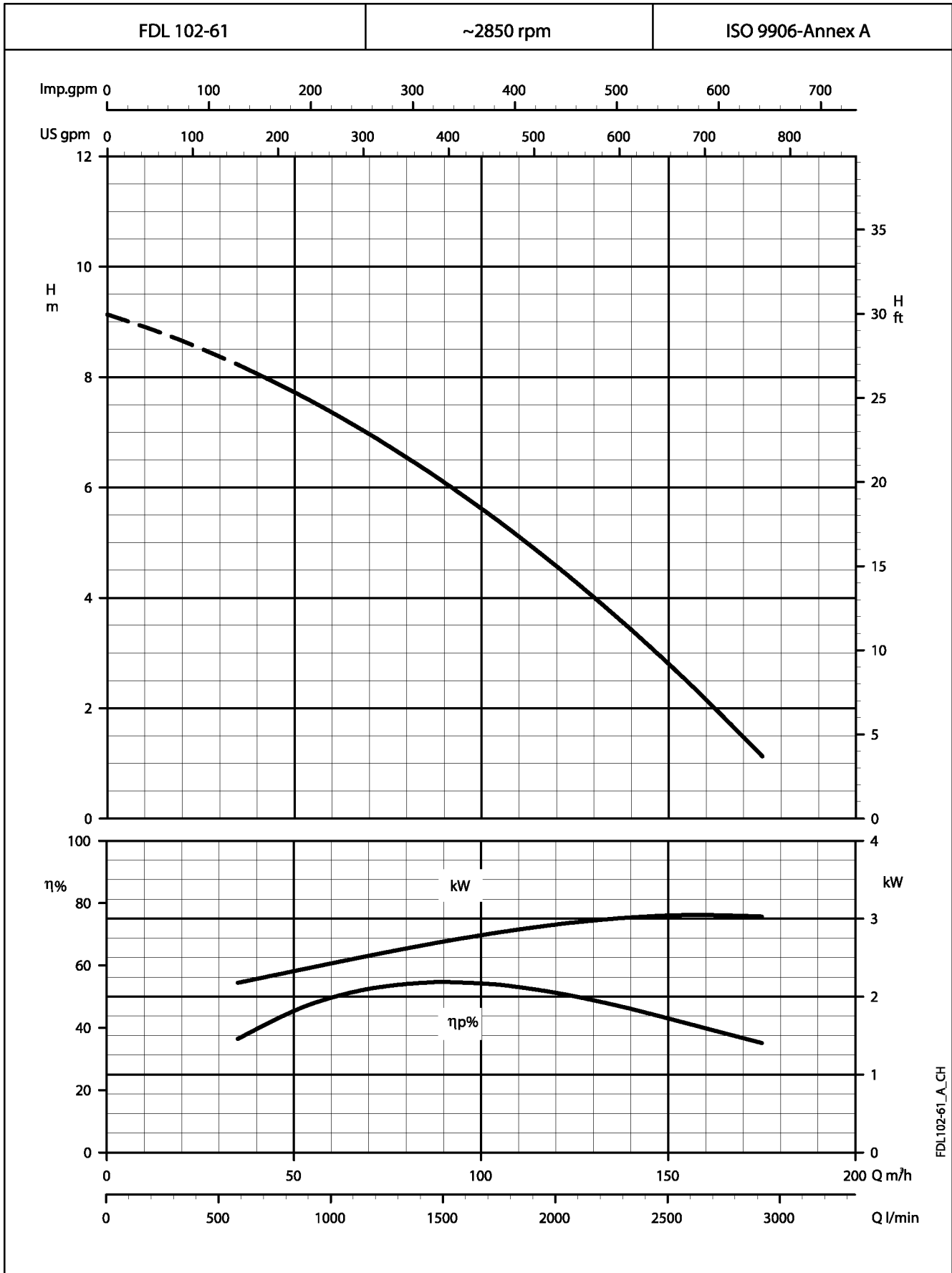

These performances are valid for liquids with density $\rho = 1.0 \text{ kg/dm}^3$ and kinematic viscosity $\gamma = 1 \text{ mm}^2/\text{s}$.

**FDL SERIES
OPERATING CHARACTERISTICS AT 950 rpm 50 Hz**

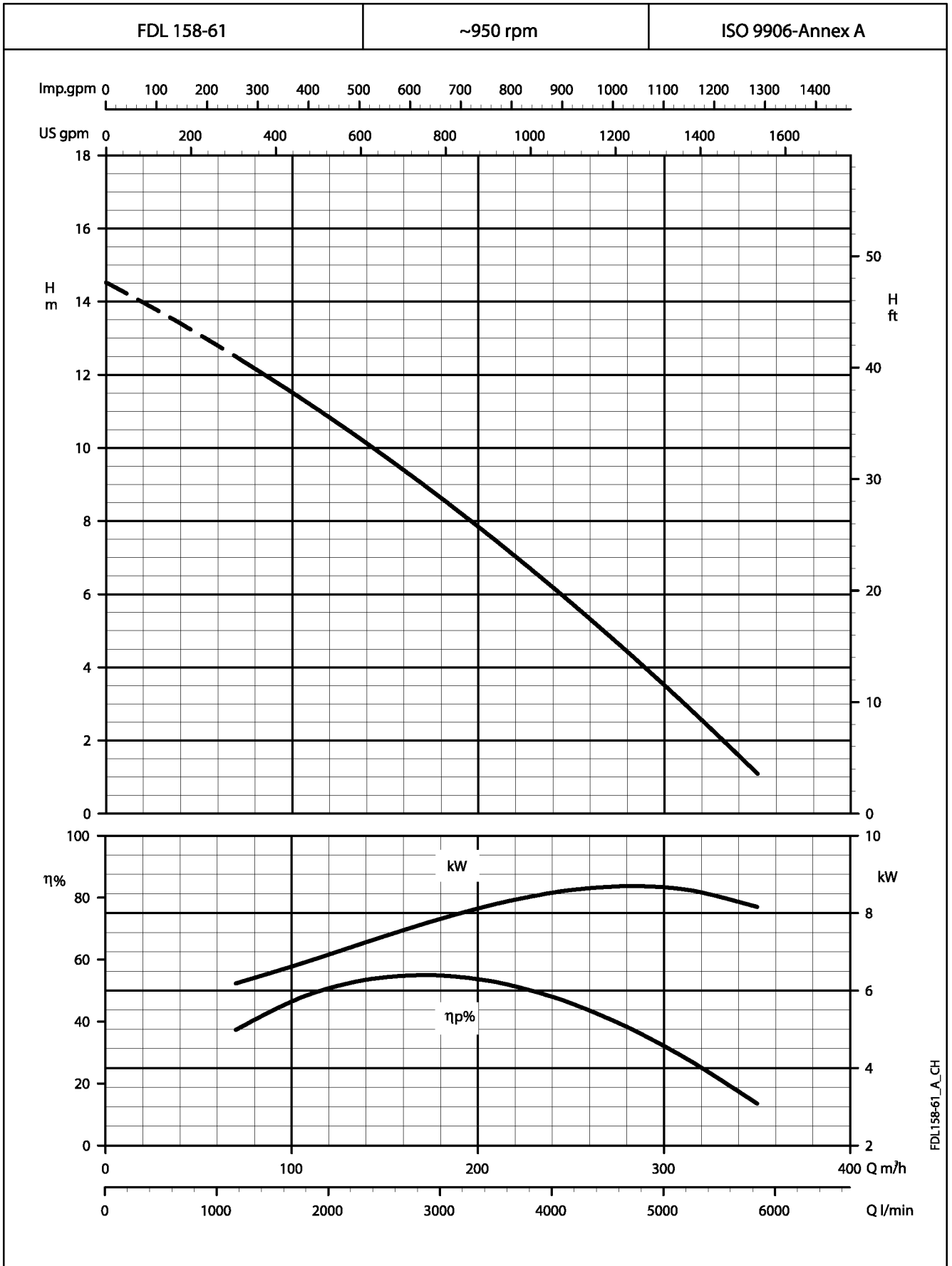

These performances are valid for liquids with density $\rho = 1.0 \text{ kg/dm}^3$ and kinematic viscosity $\gamma = 1 \text{ mm}^2/\text{s}$.

**FDL SERIES
OPERATING CHARACTERISTICS AT 950 rpm 50 Hz**

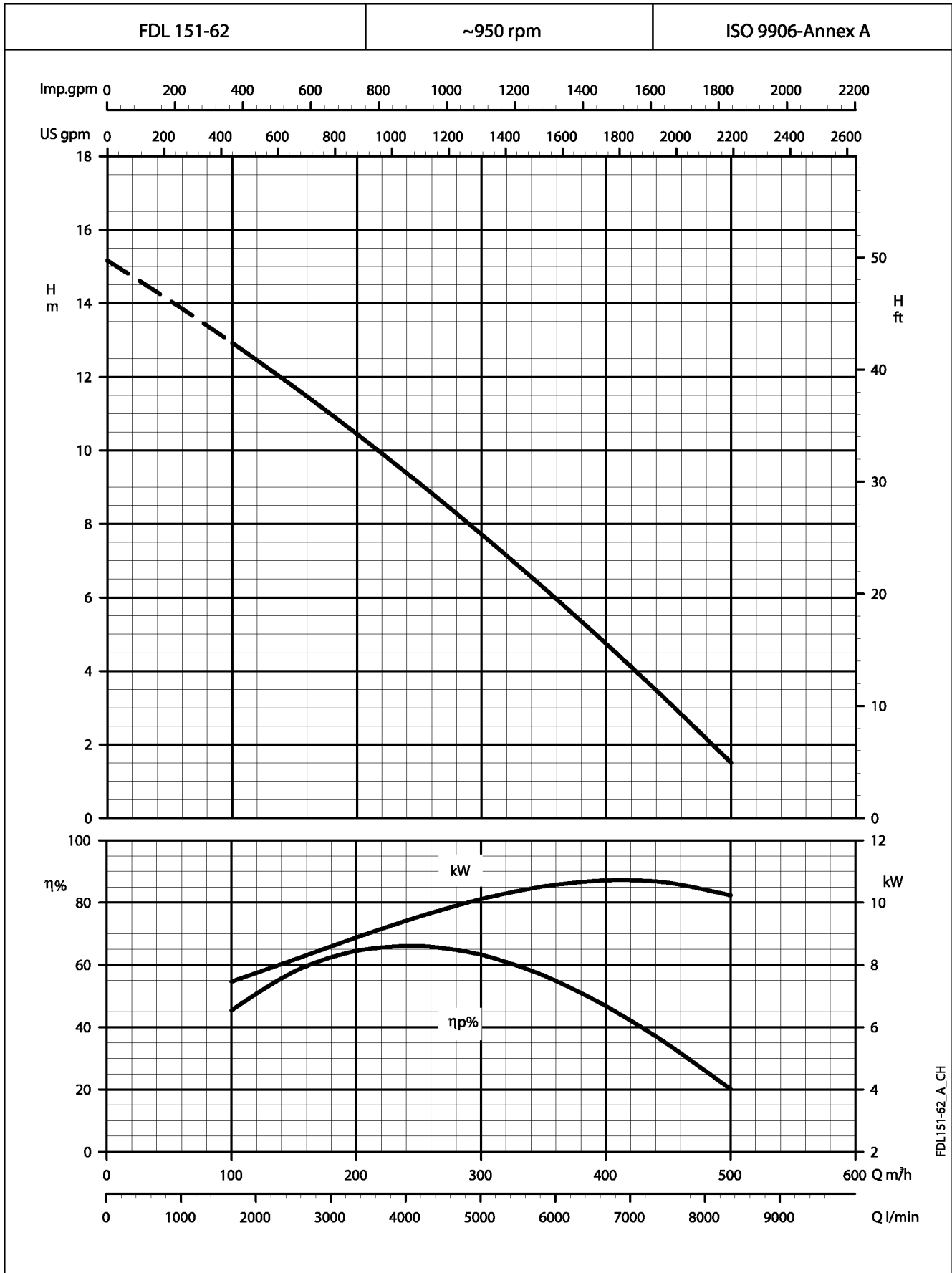

These performances are valid for liquids with density $\rho = 1.0 \text{ kg/dm}^3$ and kinematic viscosity $\gamma = 1 \text{ mm}^2/\text{s}$.

**FDL SERIES
OPERATING CHARACTERISTICS AT 950 rpm 50 Hz**

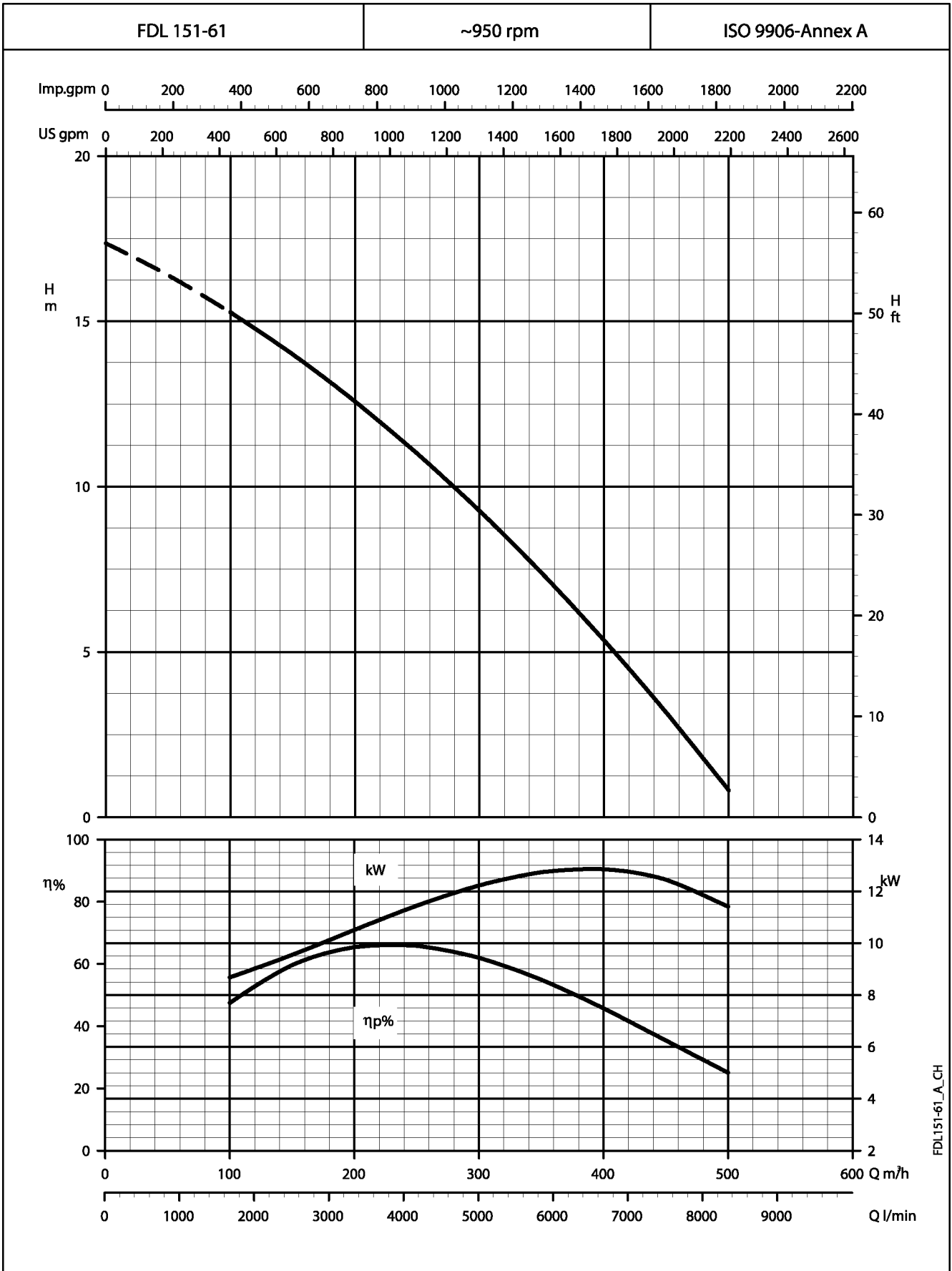

These performances are valid for liquids with density $\rho = 1.0 \text{ kg/dm}^3$ and kinematic viscosity $\gamma = 1 \text{ mm}^2/\text{s}$.

**FDL SERIES
OPERATING CHARACTERISTICS AT 950 rpm 50 Hz**

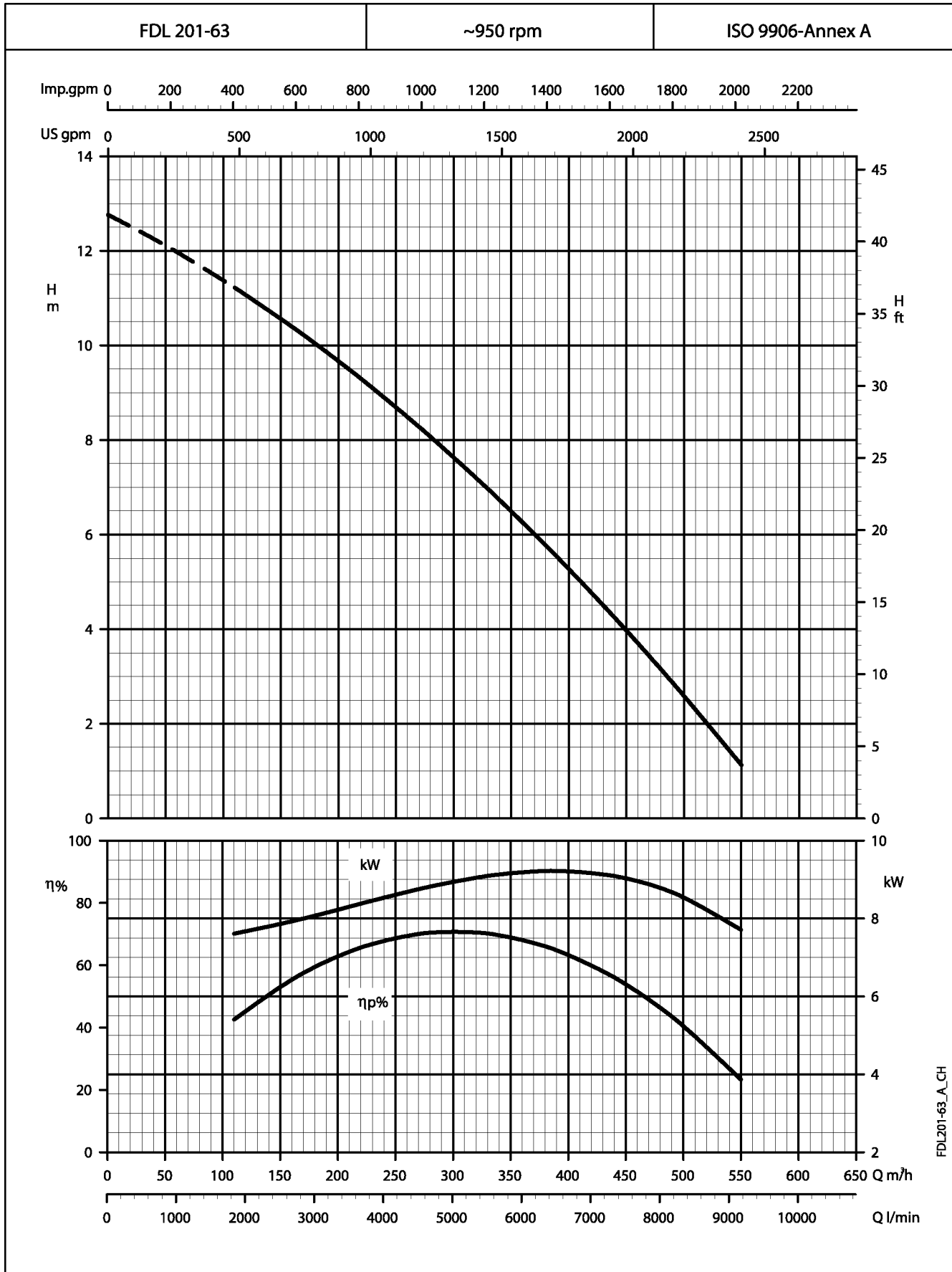

These performances are valid for liquids with density $\rho = 1.0 \text{ kg/dm}^3$ and kinematic viscosity $\nu = 1 \text{ mm}^2/\text{s}$.

**FDL SERIES
OPERATING CHARACTERISTICS AT 950 rpm 50 Hz**

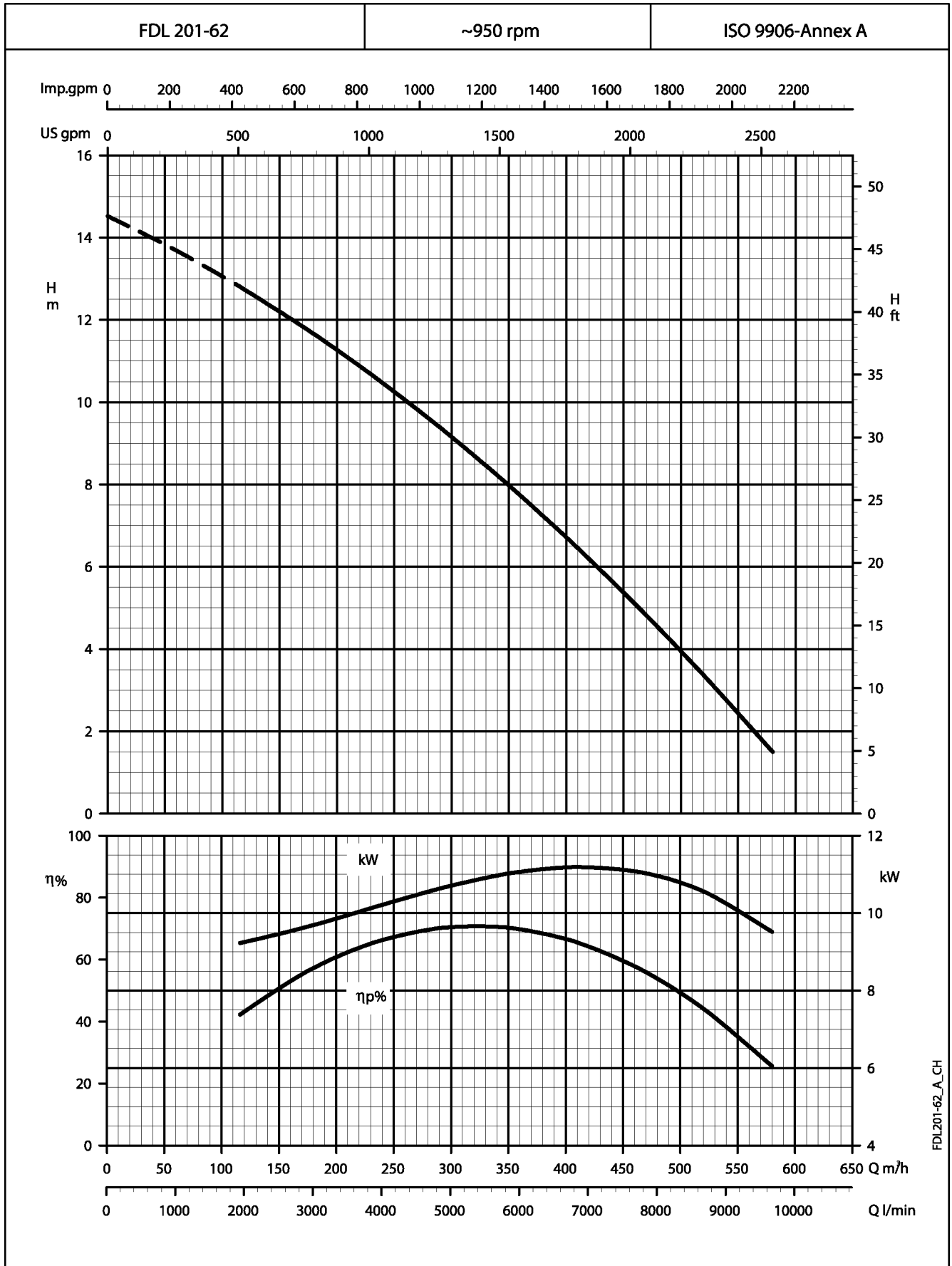

These performances are valid for liquids with density $\rho = 1.0 \text{ kg/dm}^3$ and kinematic viscosity $\gamma = 1 \text{ mm}^2/\text{s}$.

**FDL SERIES
OPERATING CHARACTERISTICS AT 950 rpm 50 Hz**

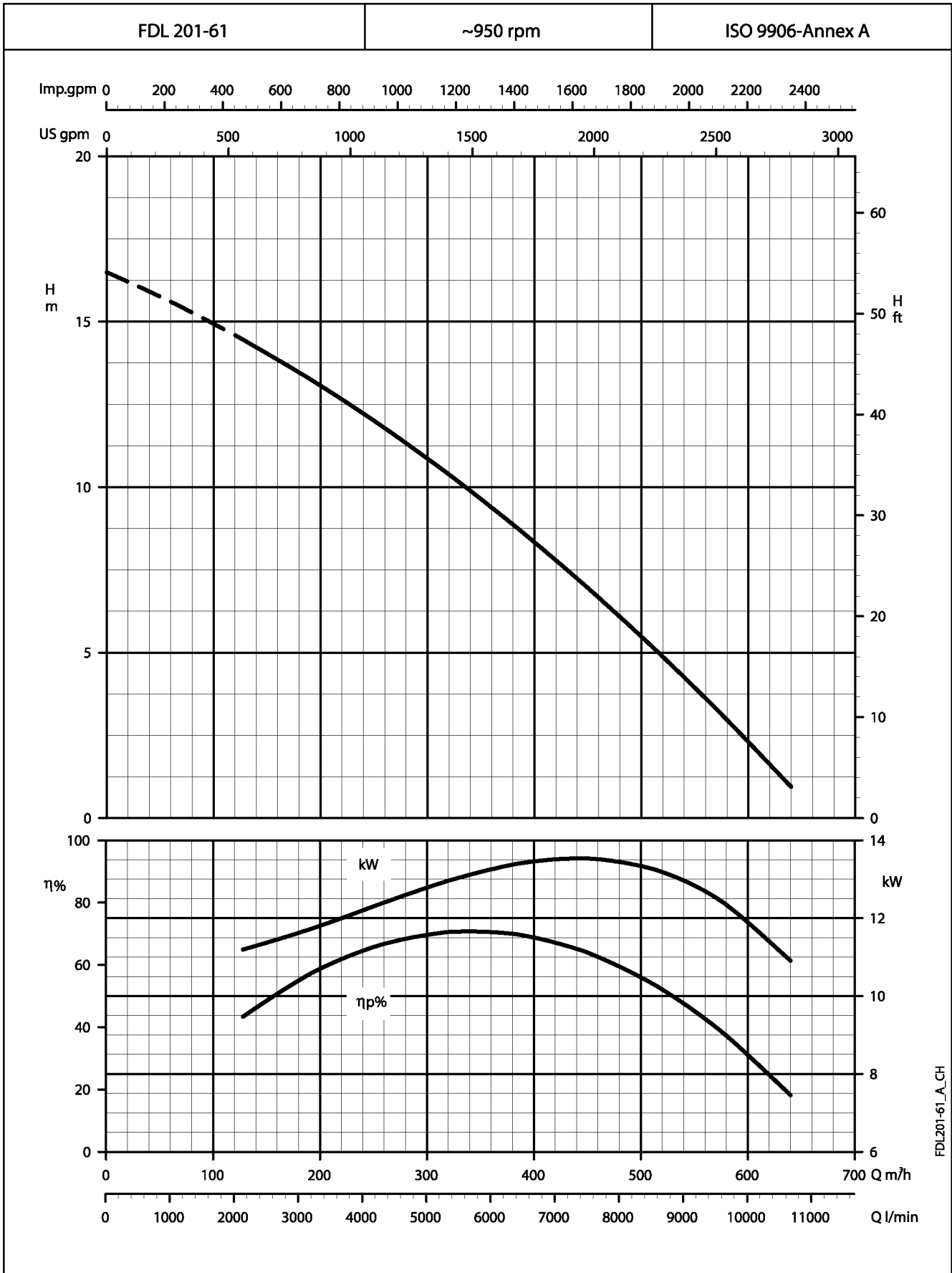

These performances are valid for liquids with density $\rho = 1.0 \text{ kg/dm}^3$ and kinematic viscosity $\nu = 1 \text{ mm}^2/\text{s}$.

**FDL SERIES
OPERATING CHARACTERISTICS AT 950 rpm 50 Hz**

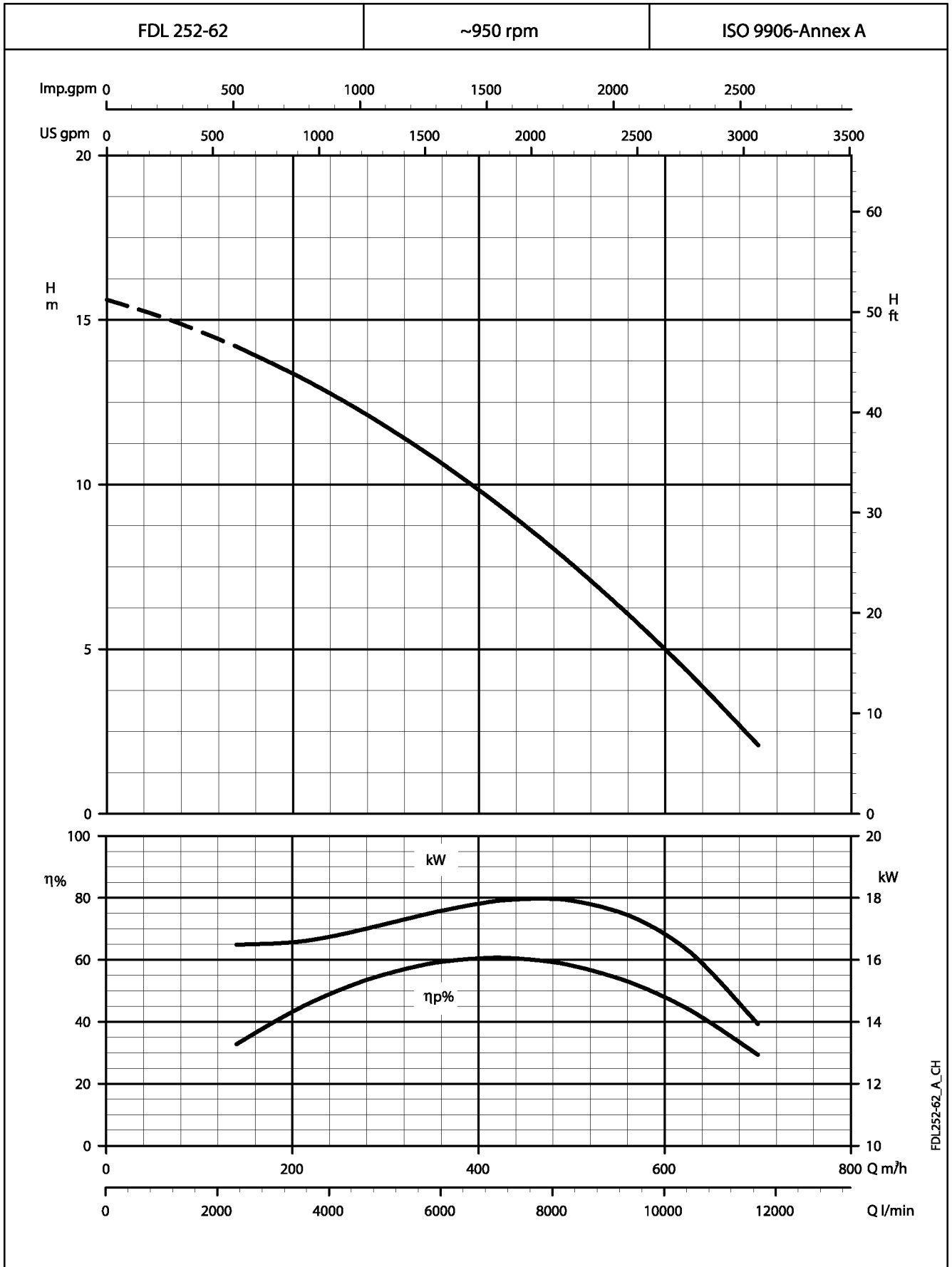

These performances are valid for liquids with density $\rho = 1.0 \text{ kg/dm}^3$ and kinematic viscosity $\gamma = 1 \text{ mm}^2/\text{s}$.

**FDL SERIES
OPERATING CHARACTERISTICS AT 950 rpm 50 Hz**

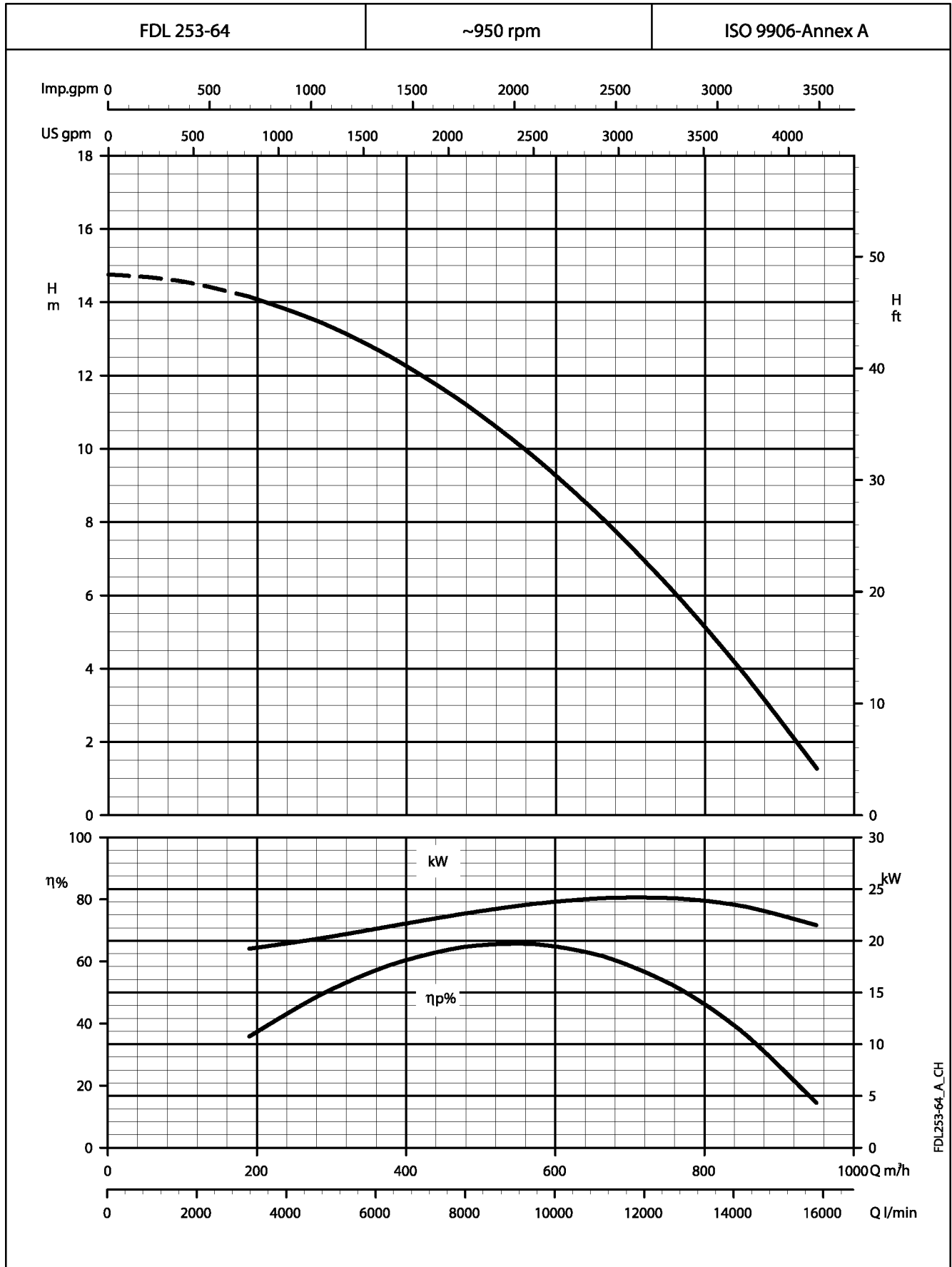

These performances are valid for liquids with density $\rho = 1.0 \text{ kg/dm}^3$ and kinematic viscosity $\nu = 1 \text{ mm}^2/\text{s}$.

**FDL SERIES
OPERATING CHARACTERISTICS AT 950 rpm 50 Hz**

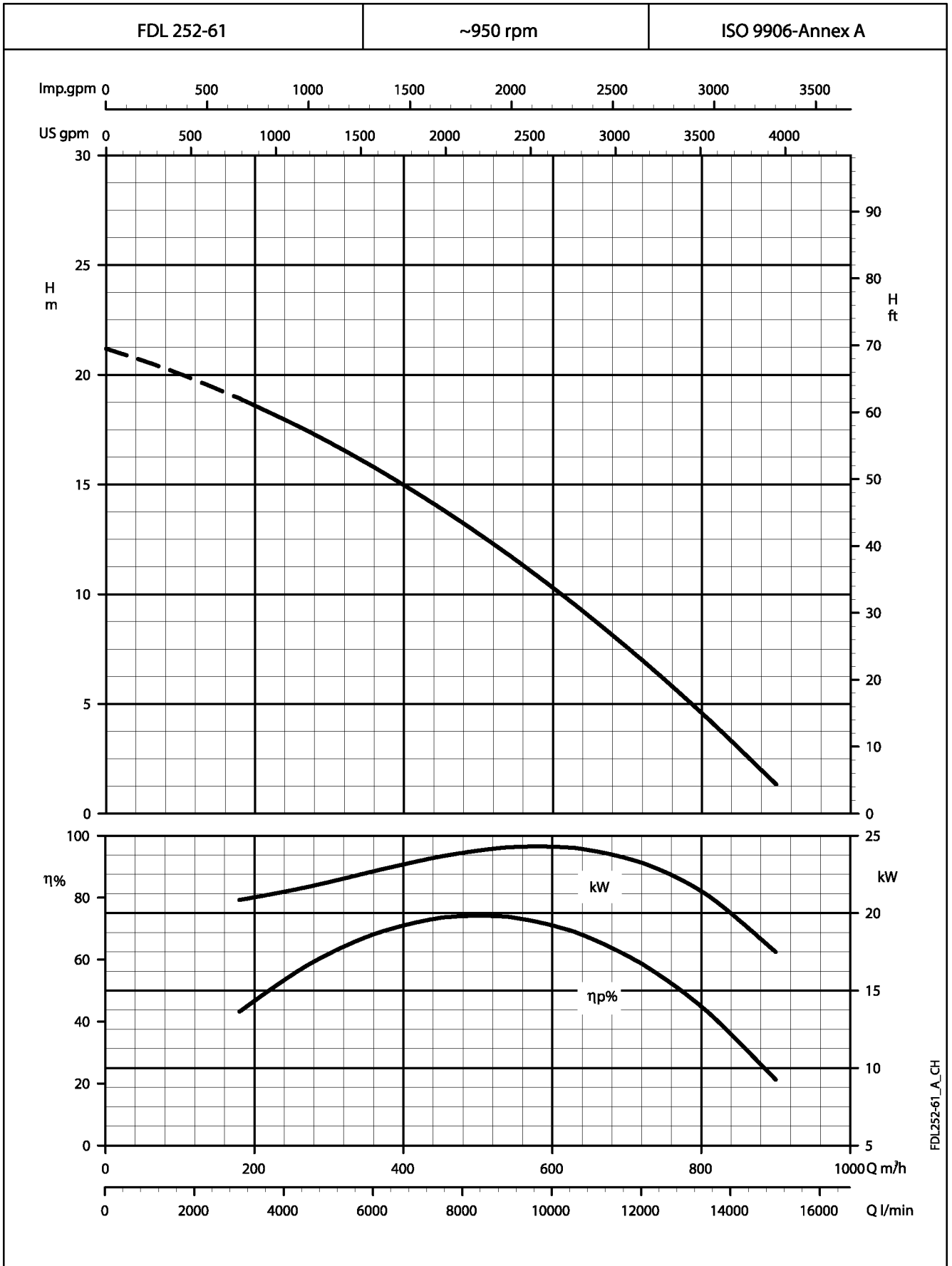

FDL252-61_A_CH

These performances are valid for liquids with density $\rho = 1.0 \text{ kg/dm}^3$ and kinematic viscosity $\gamma = 1 \text{ mm}^2/\text{s}$.

**FDL SERIES
OPERATING CHARACTERISTICS AT 950 rpm 50 Hz**

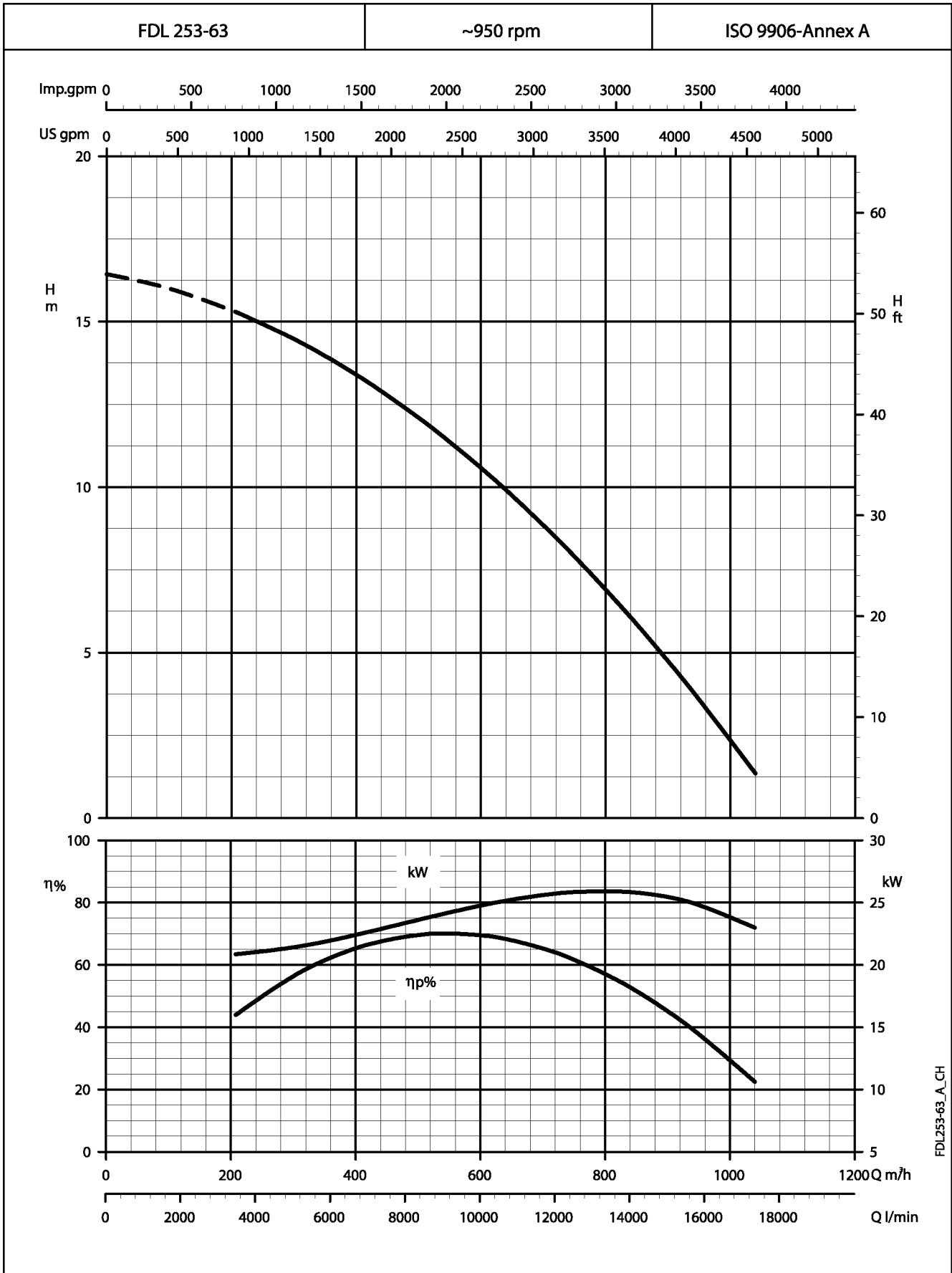

FDL253-63_A_CH

These performances are valid for liquids with density $\rho = 1.0 \text{ kg/dm}^3$ and kinematic viscosity $\nu = 1 \text{ mm}^2/\text{s}$.

**FDL SERIES
OPERATING CHARACTERISTICS AT 950 rpm 50 Hz**

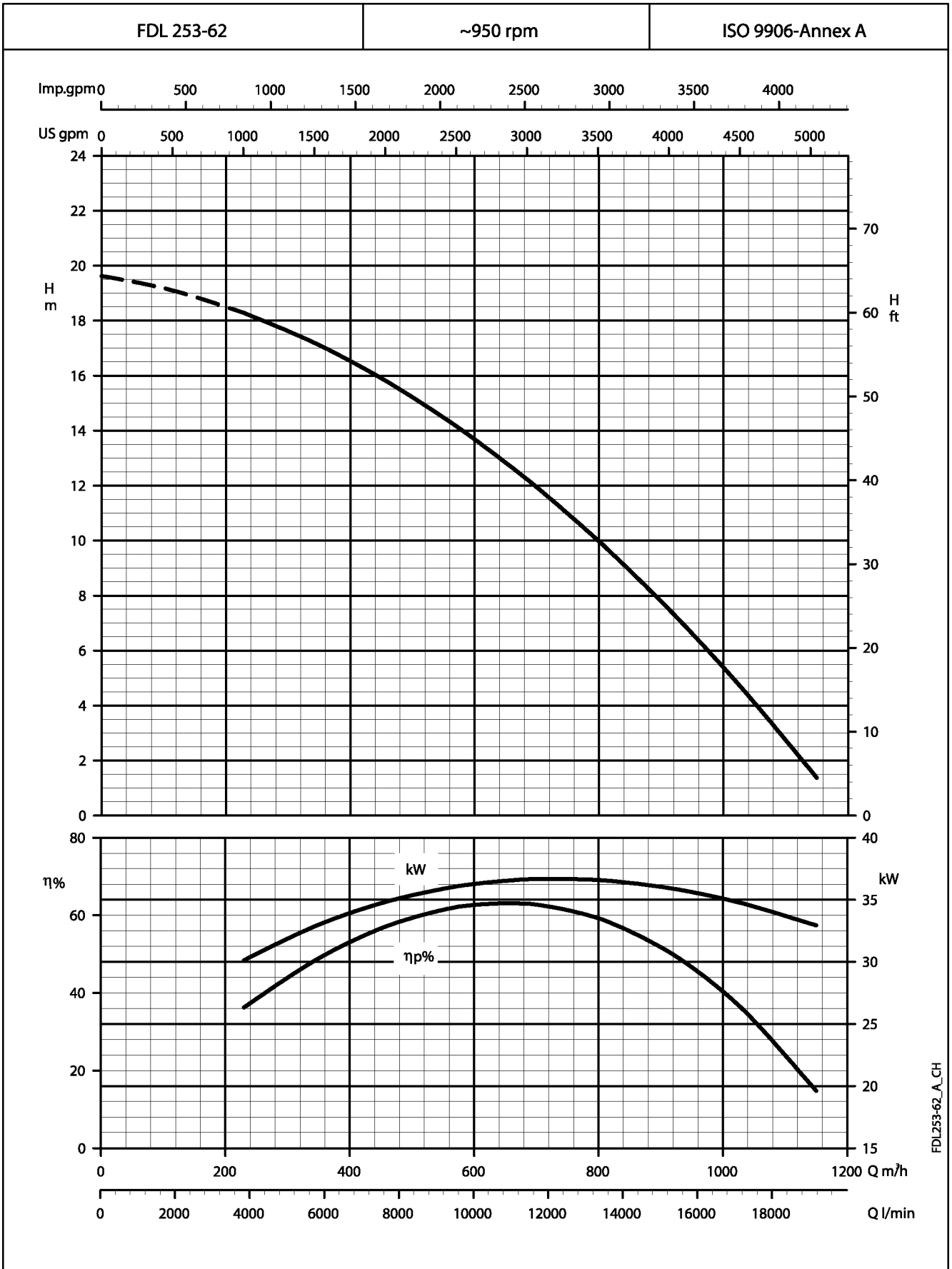

These performances are valid for liquids with density $\rho = 1.0 \text{ kg/dm}^3$ and kinematic viscosity $\gamma = 1 \text{ mm}^2/\text{s}$.

**FDL SERIES
OPERATING CHARACTERISTICS AT 950 rpm 50 Hz**

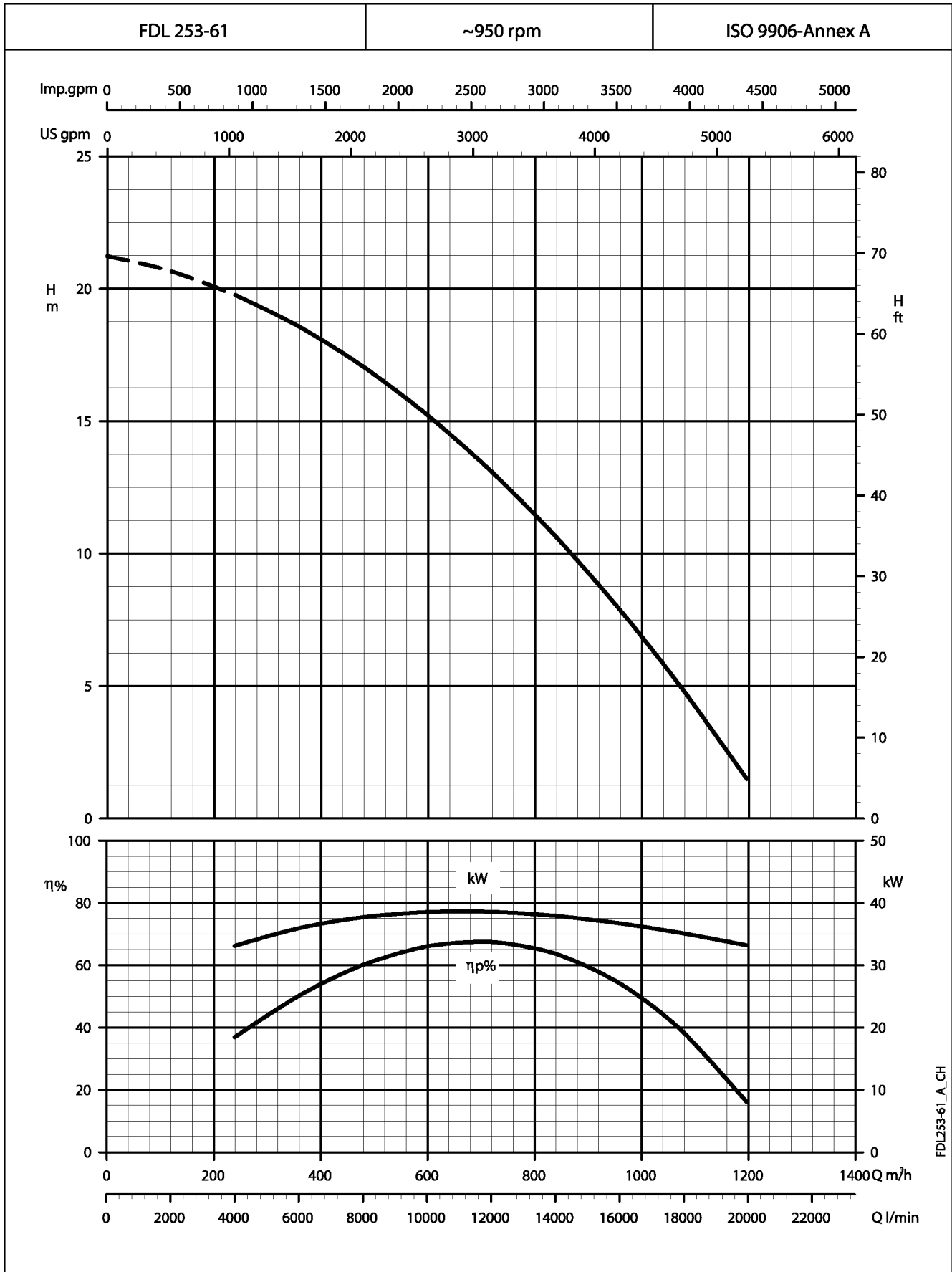

These performances are valid for liquids with density $\rho = 1.0 \text{ kg/dm}^3$ and kinematic viscosity $\nu = 1 \text{ mm}^2/\text{s}$.

DIMENSIONS AND WEIGHTS, FDL SERIES (DN65)

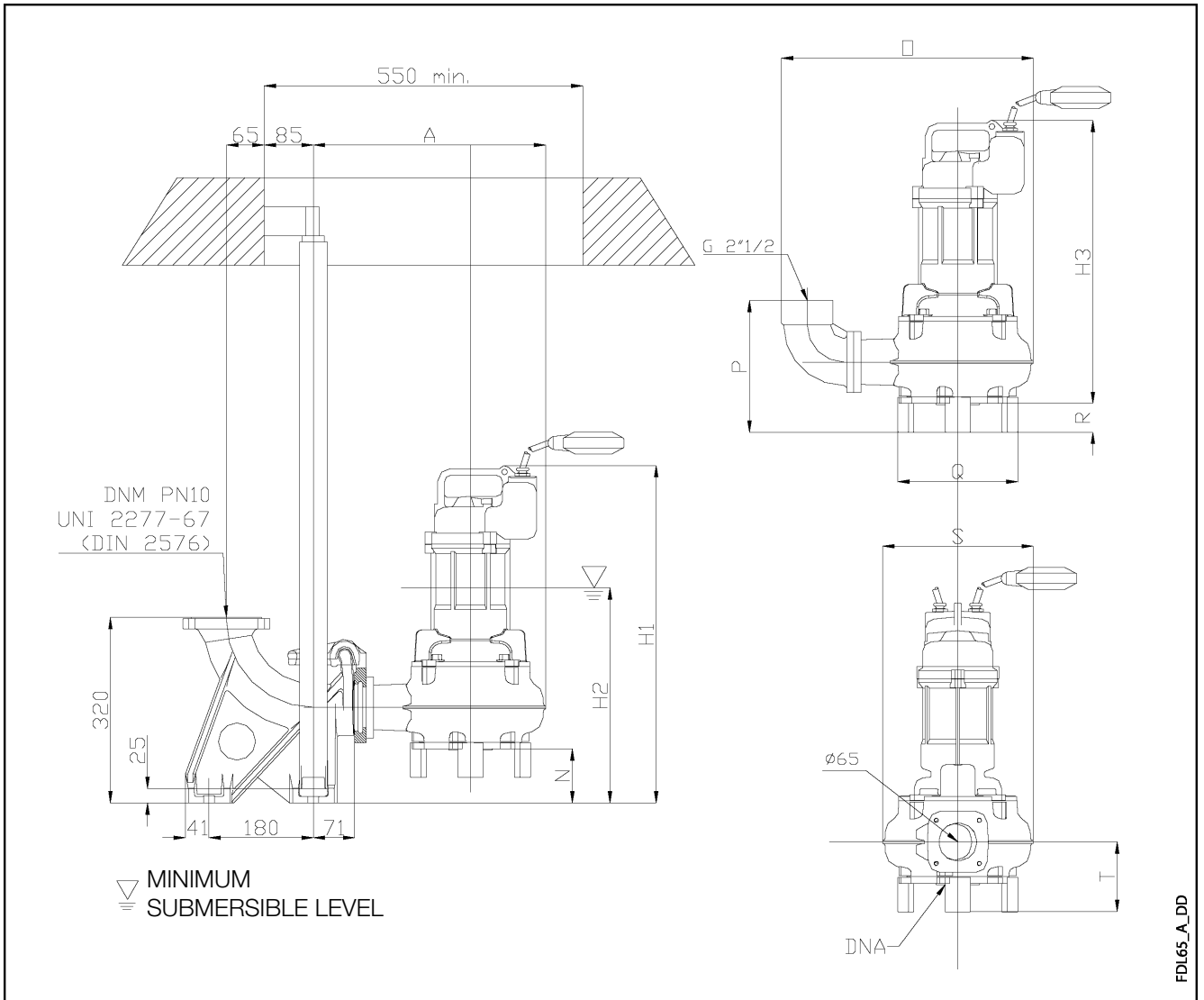

PUMP TYPE	DIMENSIONS (mm)											DNA	DNM	WEIGHT kg
	A	N	O	P	Q	R	S	T	H1	H2	H3			
FDL 62-26	501	91	434	227	190	51	260	121	582	371	538	50	65	42
FDL 62-25	501	91	434	227	190	51	260	121	582	371	538	50	65	42
FDL 62-24	501	91	434	227	190	51	260	121	582	371	538	50	65	42
FDL 62-23	501	91	434	227	190	51	260	121	582	371	538	50	65	42
FDL 62-21	414	84	447	231	200	44	269	125	494	342	450	-	70	50
FDL 64-22	414	84	447	231	190	44	269	125	534	342	450	-	70	48

FDL65_A_TD

DIMENSIONS AND WEIGHTS, FDL SERIES (DN80)

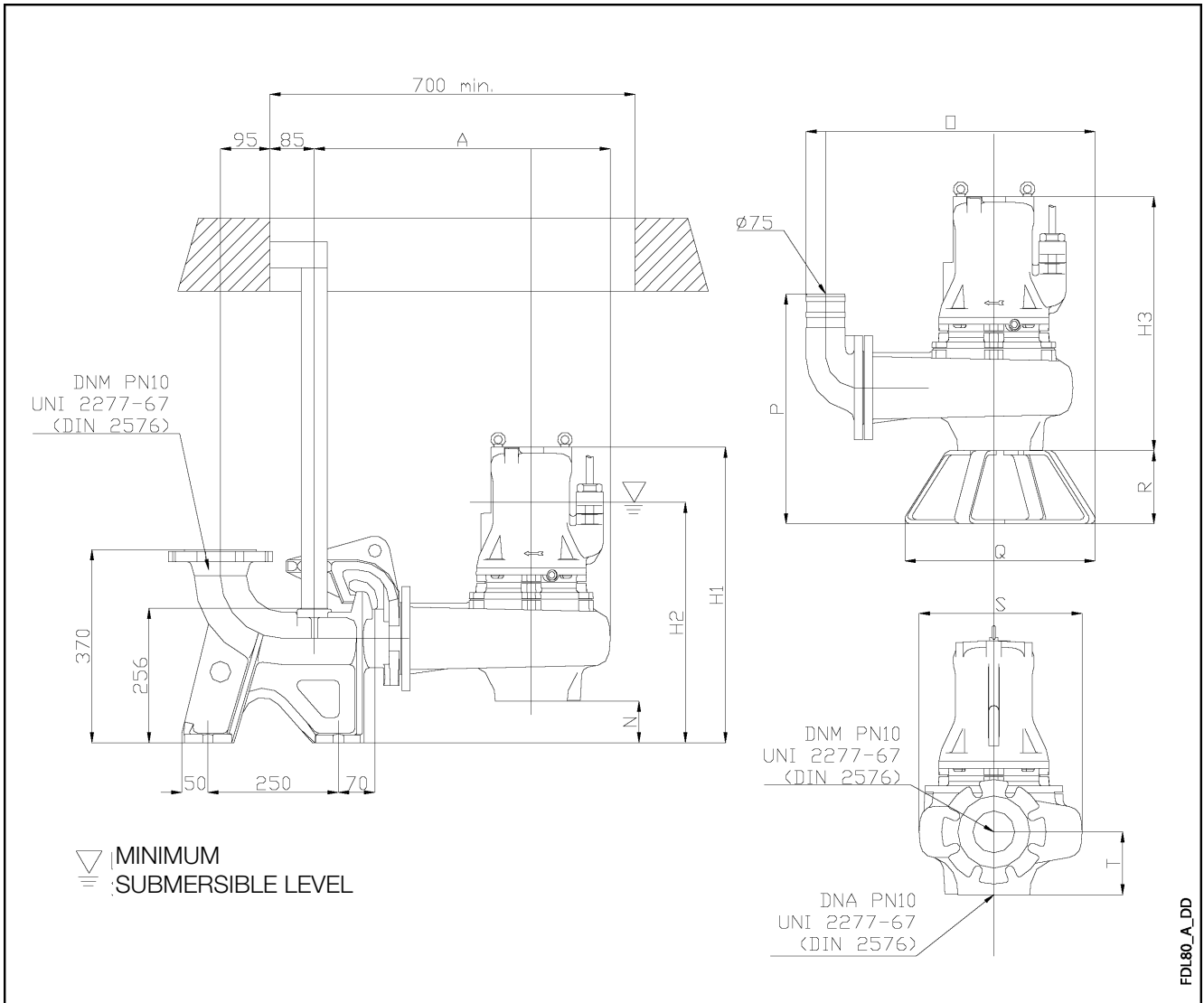

PUMP TYPE	DIMENSIONS (mm)											DNA	DNM	WEIGHT
	A	N	O	P	Q	R	S	T	H1	H2	H3			
FDL 81-42	522	84	515	436	370	140	293	116	538	436	453	DN 80	DN 80	60
FDL 82-41N	522	84	515	436	370	140	293	116	594	461	481	DN 80	DN 80	67
FDL 83-41	522	84	515	436	370	140	293	116	594	461	481	DN 80	DN 80	70
FDL 815-21	579	80	610	450	500	150	326	120	848	560	768	DN 80	DN 80	190
FDL 815-22	579	80	610	450	500	150	326	120	848	560	768	DN 80	DN 80	190
FDL 815-23	579	80	610	450	500	150	326	120	848	560	768	DN 80	DN 80	190
FDL 85-22	531	110	475	410	370	140	278	90	625	438	515	DN 80	DN 80	70
FDL 86-21	531	110	475	410	370	140	278	90	625	438	515	DN 80	DN 80	70

FDL80_A_TD

DIMENSIONS AND WEIGHTS, FDL SERIES (DN100)

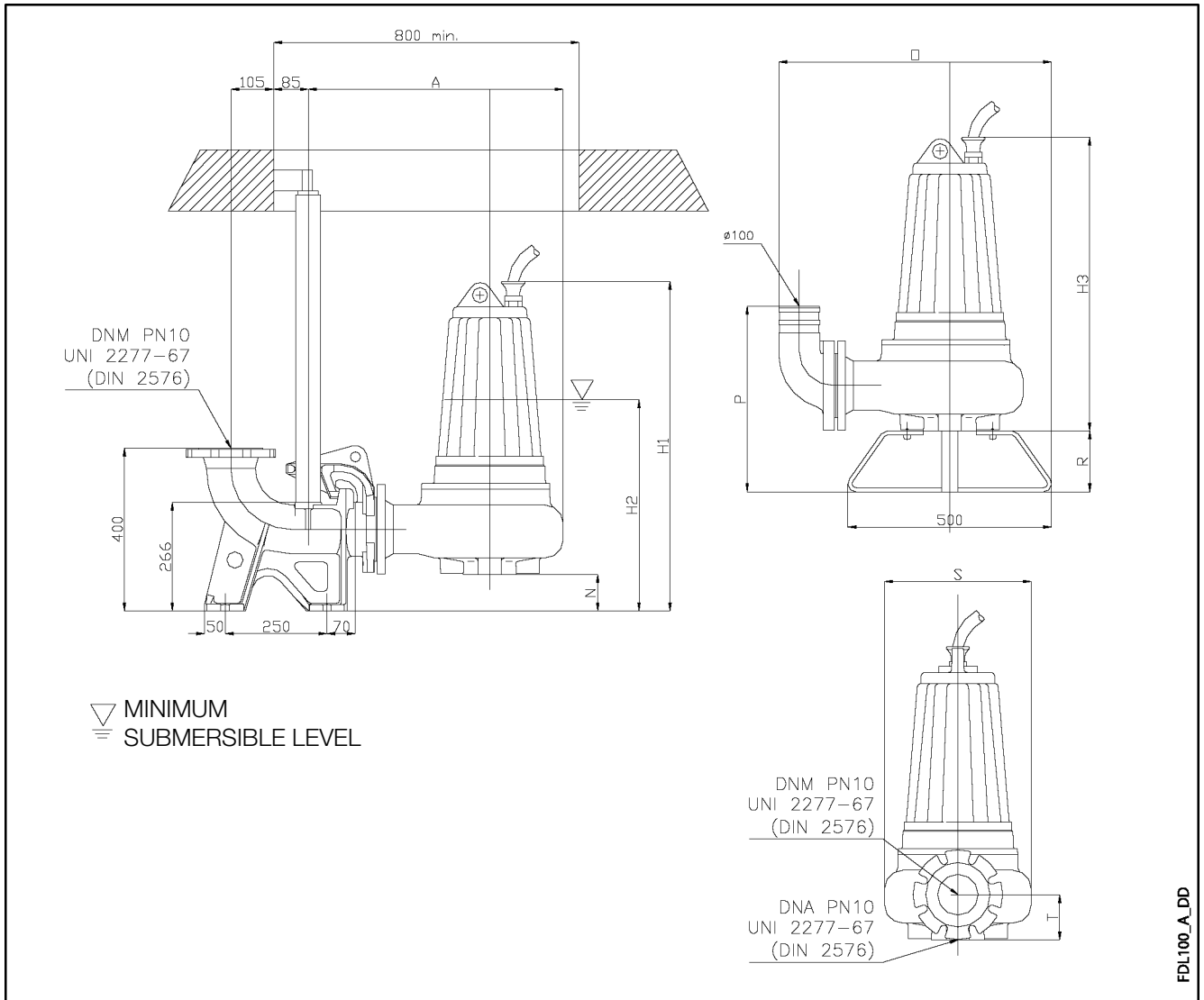

PUMP TYPE	DIMENSIONS (mm)										DNA	DNM	WEIGHT kg
	A	N	O	P	R	S	T	H1	H2	H3			
FDL 102-61	673	62	647	510	150	411	139	703	465	642	DN 125	DN 100	118
FDL 118-24	628	127	665	418	150	352	110	853	566	727	DN 125	DN 100	140
FDL 118-23	628	127	665	418	150	352	110	853	566	727	DN 125	DN 100	140
FDL 118-22	628	127	665	418	150	352	110	853	566	727	DN 125	DN 100	140
FDL 118-21	628	127	665	418	150	352	110	853	566	727	DN 125	DN 100	140
FDL 107-42	676	80	690	510	150	405	120	795	503	715	DN 125	DN 100	138
FDL 101-41	673	80	689	470	150	401	120	859	532	779	DN 125	DN 100	196
FDL 104-42	673	62	690	501	150	411	139	703	465	642	DN 125	DN 100	117
FDL 104-41	673	62	690	484	150	411	139	703	465	641	DN 125	DN 100	117
FDL 106-41	676	80	690	511	150	405	120	795	503	715	DN 125	DN 100	134
FDL 107-41	626	50	660	504	150	390	150	780	522	700	DN 125	DN 100	125
FDL 109-42	641	54	670	510	150	395	155	880	549	826	DN 125	DN 100	189
FDL 109-41	641	54	670	510	150	395	155	880	549	826	DN 125	DN 100	189

FDL100_A_TD

DIMENSIONS AND WEIGHTS, FDL SERIES (DN150)

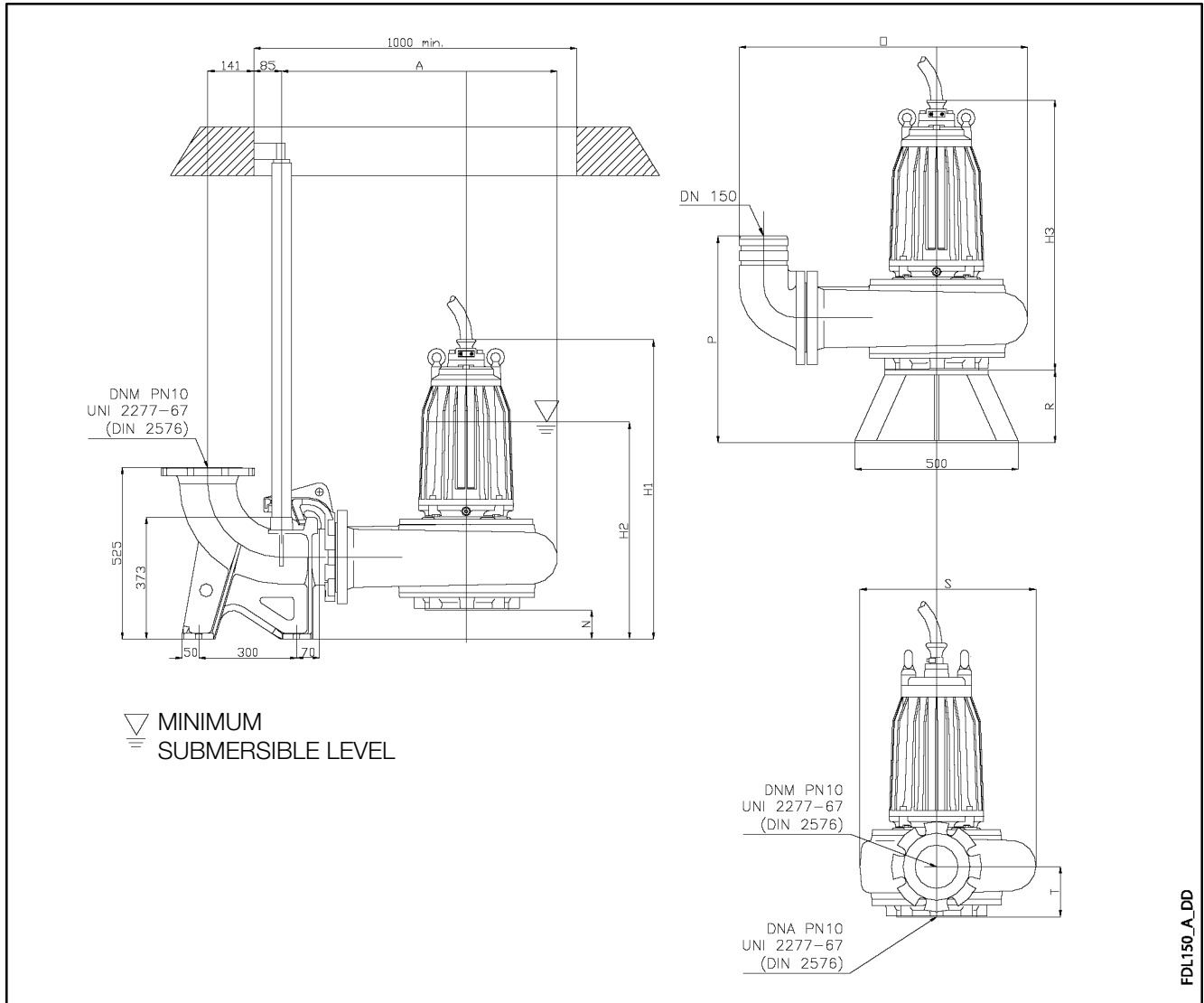

PUMP TYPE	DIMENSIONS (mm)										DNA	DNM	WEIGHT kg
	A	N	O	P	R	S	T	H1	H2	H3			
FDL 158-61	846	90	885	635	225	540	160	965	614	876	DN 150	DN 150	280
FDL 151-62	846	90	885	635	225	548	160	1045	664	955	DN 150	DN 150	341
FDL 151-61	846	90	885	635	225	548	160	1045	664	955	DN 150	DN 150	330
FDL 153-43	846	90	885	635	225	540	160	1045	664	955	DN 150	DN 150	328
FDL 153-43/1	846	90	680	385	225	540	160	1045	664	955	DN 150	DN 150	330
FDL 153-41/1	846	90	680	385	225	540	160	1045	664	955	DN 150	DN 150	330
FDL 153-42	846	90	885	635	225	540	160	1045	664	955	DN 150	DN 150	328
FDL 153-41	846	90	885	635	225	540	160	1045	664	955	DN 150	DN 150	330
FDL 154-43	893	73	727	385	225	566	178	1124	788	1052	DN 150	DN 150	550
FDL 154-42	893	73	727	385	225	566	178	1124	788	1052	DN 150	DN 150	550
FDL 154-41	893	73	727	385	225	566	178	1124	788	1052	DN 150	DN 150	550
FDL 152-43	846	90	885	635	225	540	160	916	664	826	DN 150	DN 150	280
FDL 152-42	846	90	885	635	225	540	160	1045	664	1180	DN 150	DN 150	350
FDL 152-41	846	90	885	635	225	540	160	1045	664	1180	DN 150	DN 150	350

FDL150_A_TD

DIMENSIONS AND WEIGHTS, FDL SERIES (DN200)

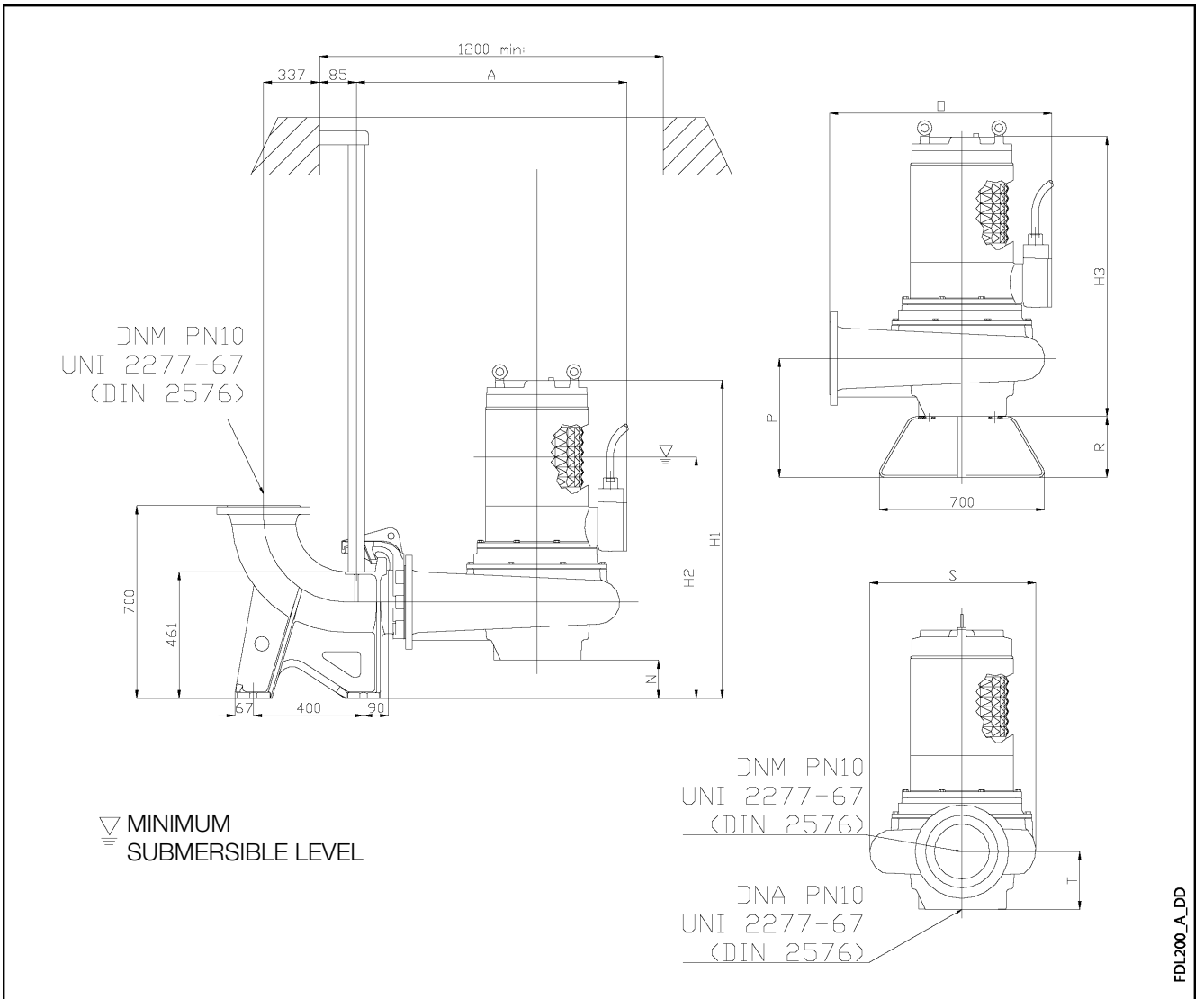

PUMP TYPE	DIMENSIONS (mm)										DNA	DNM	WEIGHT kg
	A	N	O	P	R	S	T	H1	H2	H3			
FDL 201-63	958	139	782	433	222	604	211	1128	764	989	DN 200	DN 200	420
FDL 201-62	958	139	782	433	222	604	211	1128	764	989	DN 200	DN 200	420
FDL 201-61	958	139	782	433	222	604	211	1128	764	989	DN 200	DN 200	420

FDL200_A_TD

DIMENSIONS AND WEIGHTS, FDL SERIES (DN250)

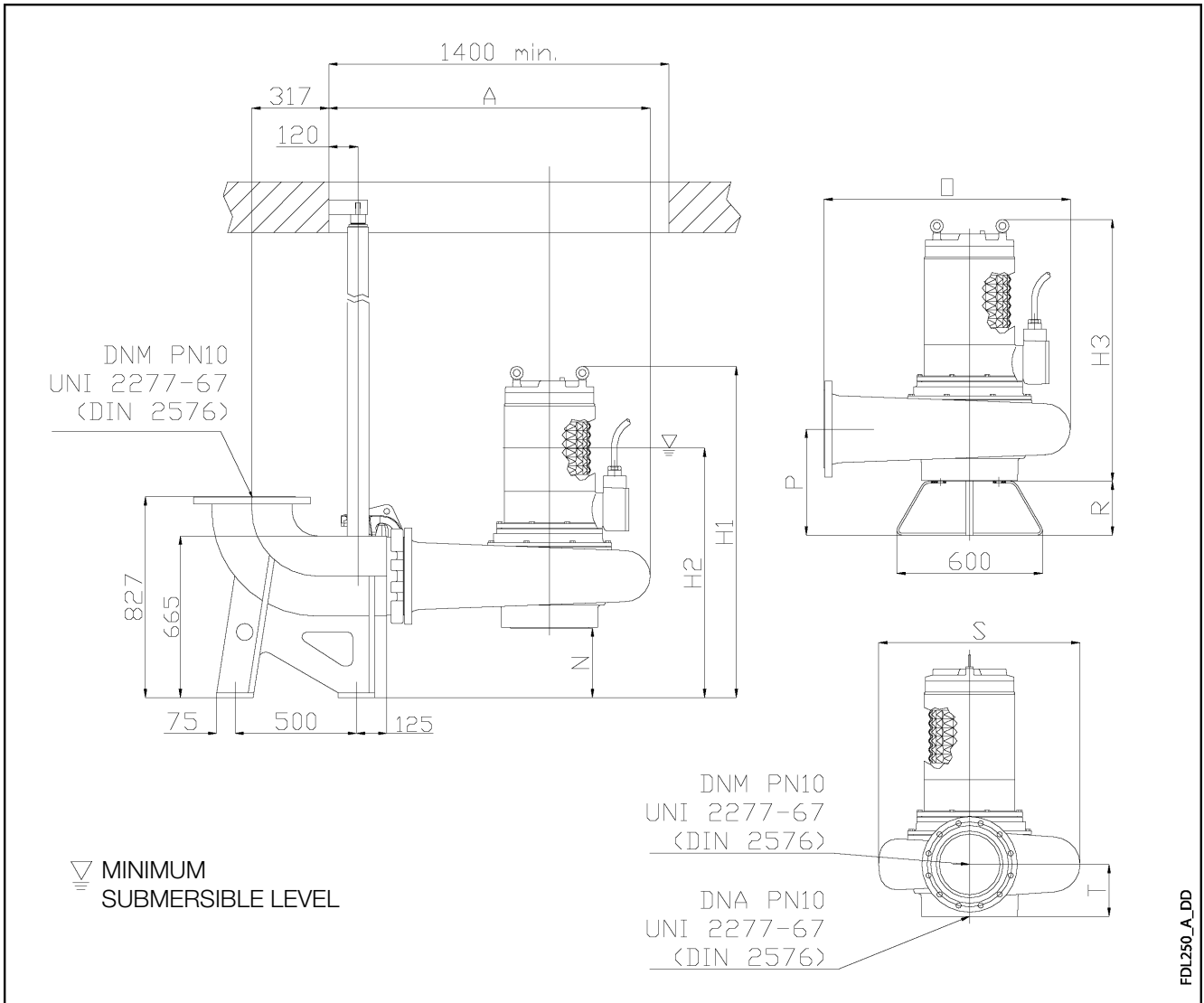

FDL250_A_DD

PUMP TYPE	DIMENSIONS (mm)										DNA	DNM	WEIGHT kg
	A	N	O	P	R	S	T	H1	H2	H3			
FDL 252-62	1323	286	1014	436	222	829	214	1363	1027	1077	DN 250	DN 250	584
FDL 253-64	1203	286	1014	436	222	829	214	1363	1027	1077	DN 250	DN 250	584
FDL 252-61	1323	286	1014	436	222	829	214	1363	1027	1077	DN 250	DN 250	584
FDL 253-63	1203	286	1014	436	222	829	214	1363	1027	1077	DN 250	DN 250	584
FDL 253-62	1203	286	1014	436	222	829	214	1363	1027	1077	DN 250	DN 250	584
FDL 253-61	1203	286	1014	436	222	829	214	1363	1027	1077	DN 250	DN 250	584

FDL250_A_TD

**PUMP SECTION
FDL SERIES**

FDL

Shafts: made of AISI 420B stainless steel

AISI

Motor: three-phase asynchronous 2-4-6 poles, insulation class F (155°C). Dry, cooled by the surrounding liquid.

Oil chamber with water sensor for audible and visual signalling. The oil lubricates and cools the seals and emulsifies any water leaks. The pump is equipped with two mechanical seals for perfect insulation between the electric motor and the pumped liquid. Upper seal: ceramic/carbon Lower seal: silicon carbide/silicon carbide.

The radial bearings are sized for minimum 10,000 hours of operation.

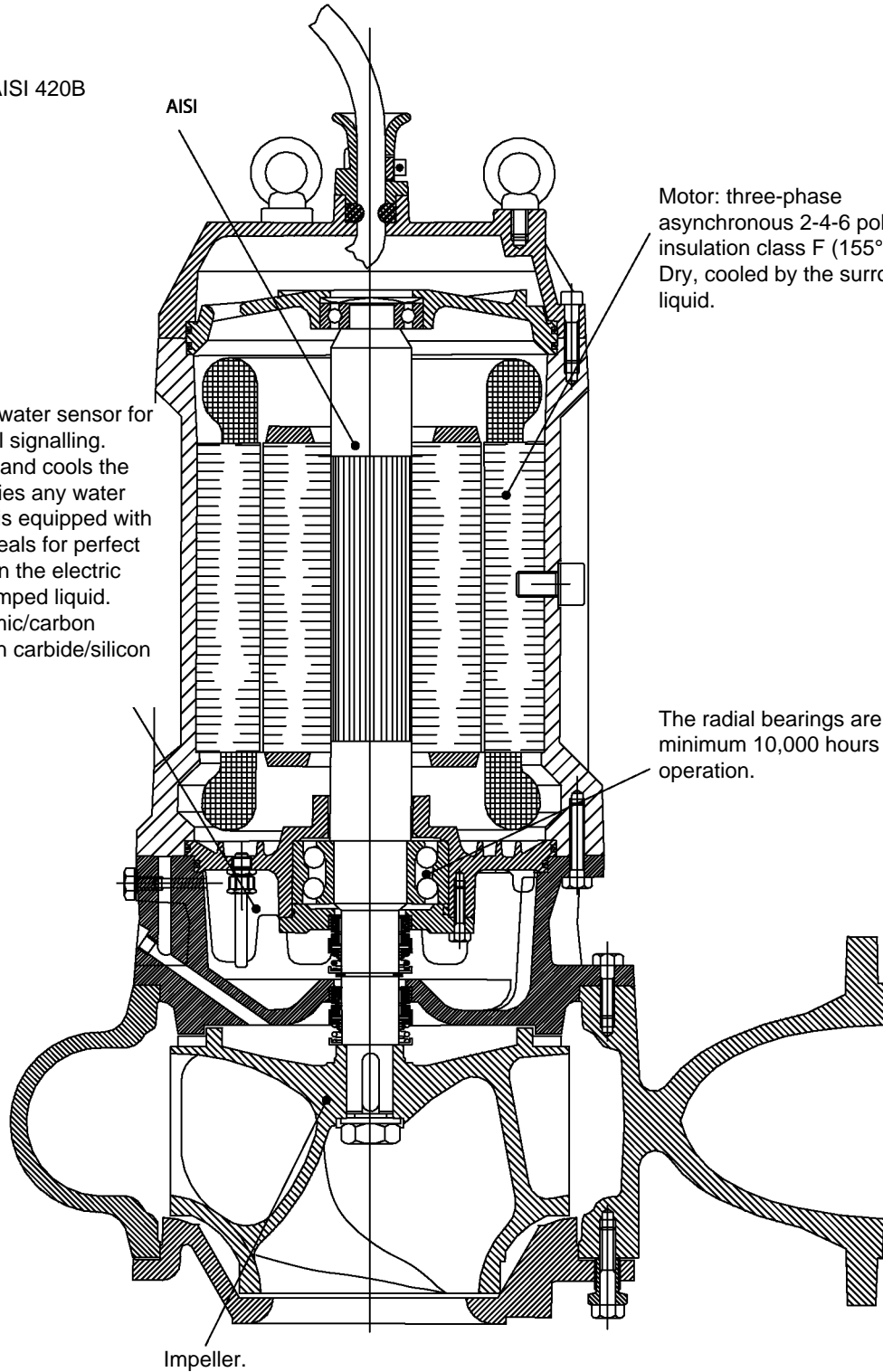

Impeller.

Submersible Electric Pumps

FDLV Series



MARKET SECTORS

DOMESTIC, AGRICULTURAL, INDUSTRIAL, CONSTRUCTION, MUNICIPAL, MINING INDUSTRY.

APPLICATIONS

- Handling of sewage, liquids, wastewater and industrial sludge, draining of flooded excavations and marshy ground.

SPECIFICATIONS

- **Delivery:** up to 312 m³/h.
- **Head:** up to 47 m.
- Maximum liquid **temperature:** 25-40°C C (see hydraulic performance table).
- Maximum immersion depth: 20 m.
- **Passes solids** 5 to 100 mm in diameter (see hydraulic performance table).
 - Motor with IP 68 **protection** and class F insulation (155°C).
 - Power supply: three-phase, 50 Hz.
- **Motor power:** up to 29 kW.
- Maximum number of starts per hour: approx. 20 (possibly more, depending on the application).

CONSTRUCTION CHARACTERISTICS

- Sturdy cast iron construction.
- Vortex-type open **impeller**.
- Double seal: Silicon Carbide / Silicon Carbide inner seal, Ceramic / Carbon upper seal or Nitrile Rubber seal ring with interposed oil chamber.
- Adjustable volute bottom cover to compensate for impeller wear and ensure stable long-lasting hydraulic performances.
- Oversized motor bearings.
- 10-metre power supply cable with neoprene sheath (H07RN-F).
- Moisture sensor in oil chamber (see electric data table).

OPTIONAL FEATURES

- Cathodic protection
 - Ceramic treatment
 - Cooling sleeve for dry installations
 - Version without float.
 - Flameproof construction (EEx).

ACCESSORIES / INSTALLATION

- Lowering system.
- 90° delivery union.
- Threaded flange for delivery port.
- Tripod stand.
- Non-return ball valves.
- Floats for solids-laden waters.
- Command and control panels.

IDENTIFICATION CODE

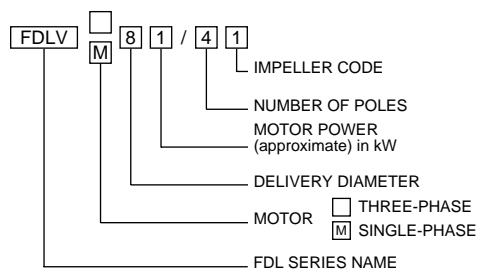

TABLE OF MATERIALS

PART	FDLV MATERIAL
Impeller, Pump body, Motor casing, Volute bottom, Upper cover	250 CAST IRON UNI-ISO 185
Shaft	STAINLESS STEEL (AISI 420B)
Bearings	LIFETIME LUBRICATED BALL TYPE
Upper seal	CERAMIC-GRAPHITE OR NITRILE RUBBER SEAL RING
Lower seal	SILICON CARBIDE / SILICON CARBIDE
Gaskets	NITRILE RUBBER
Bolts and screws	STAINLESS STEEL (AISI 304)

FDLV SERIES HYDRAULIC PERFORMANCE TABLE

PUMP TYPE	ABS. POW.	rpm	Q = DELIVERY												DNM	PASSES SOLIDS UP TO (mm)	MAX LIQUID TEMP. °C
			l/min 0	125	250	400	500	600	800	1000	1200	1600	1800				
			m ³ /h 0	7,5	15	24	30	36	48	60	72	96	108				
			H = TOTAL HEAD METERS COLUMN OF WATER														
FDLV 62-22	3,2	2850	15,4	13,5	11,5	9,2	7,6	6,0	2,8						DN 65	50	40
FDLV 62-21	3,4	2850	18,5	16,3	14,1	11,5	9,7	8,0	4,6	1,2					DN 65	50	25
FDLV 84-22	4,5	2850	19,9	18,0	16,1	13,8	12,3	10,8	7,8	4,8	1,8				DN 80	50	40
FDLV 85-21	6,2	2850	24,8	22,8	20,7	18,3	16,6	15,0	11,8	8,6	5,4				DN 80	50	40
FDLV 815-24	18,0	2850	36,8	35,7	34,5	33,1	32,1	31,1	29,0	26,8	24,5	19,5			DN 80	40x50	40
FDLV 815-23	18,0	2850	38,6	37,4	36,2	34,6	33,5	32,4	30,1	27,6	25,0	19,5			DN 80	40x50	40
FDLV 815-22	18,0	2850	43,2	41,7	40,1	38,3	37,2	36,0	33,9	31,8	29,8				DN 80	40x50	40
FDLV 815-21	18,0	2850	47,2	45,5	43,9	42,0	40,8	39,6	37,3	35,2					DN 80	40x50	40
FDLV 62-45	1,1	1450	6,7	5,8	4,9	3,6	2,7	1,7							65	50	40
FDLV 62-44	1,3	1450	8,0	7,1	6,1	4,8	3,8	2,8	0,5						65	50	40
FDLV 61-42	1,5	1450	7,6	7,2	6,7	5,9	5,2	4,4	2,5						DN 65	50	40
FDLV 62-43	1,6	1450	9,6	8,5	7,4	5,9	4,9	3,9	1,6						65	50	40
FDLV 61-41	1,6	1450	8,3	7,8	7,2	6,3	5,7	4,9	3,2	1,2					DN 65	50	40
FDLV 82-42N	2,4	1450	8,5	8,0	7,5	6,9	6,5	6,1	5,2	4,3	3,4	1,5			DN 80	64	40
FDLV 82-41N	3,0	1450	10,4	9,9	9,3	8,6	8,2	7,7	6,7	5,7	4,7	2,6	1,4		DN 80	64	40
PUMP TYPE	ABS. POW.	rpm	Q = DELIVERY												DNM	PASSES SOLIDS UP TO (mm)	TEMP. MAX LIQUIDO °C
			l/min 0	400	600	800	1000	1200	1400	1600	2200	2500	3400				
			m ³ /h 0	24	36	48	60	72	84	96	132	150	204				
			H = TOTAL HEAD METERS COLUMN OF WATER														
FDLV 83-42N	3,6	1450	10,4	9,2	8,5	7,8	7,0	6,2	5,3	4,4	1,5				DN 80	64	40
FDLV 104-41	4,5	1450	12,3	10,7	9,9	9,0	8,1	7,1	6,1	5,0	1,5				DN 100	70x90	40
FDLV 83-41N	4,6	1450	12,8	11,6	10,9	10,2	9,3	8,4	7,5	6,4	2,9	0,8			DN 80	64	40
FDLV 106-42	5,4	1450	13,9	12,7	12,0	11,2	10,4	9,5	8,5	7,4	3,9	2,0			DN 100	70x90	40
FDLV 106-41	6,8	1450	16,6	15,3	14,5	13,7	12,7	11,7	10,7	9,5	5,7	3,5			DN 100	70x90	40
FDLV 158-64	6,6	950	11,0	9,7	9,1	8,5	7,9	7,3	6,8	6,2	4,7	3,9	1,9		DN 150	100	40
FDLV 158-63	7,9	950	12,1	11,0	10,4	9,8	9,3	8,7	8,1	7,6	5,9	5,0	2,5		DN 150	100	40
PUMP TYPE	ABS. POW.	rpm	Q = DELIVERY												DNM	PASSES SOLIDS UP TO (mm)	TEMP. MAX LIQUIDO °C
			l/min 0	1200	1400	1800	2200	2500	2900	3400	3900	4400	5200				
			m ³ /h 0	72	84	108	132	150	174	204	234	264	312				
			H = TOTAL HEAD METERS COLUMN OF WATER														
FDLV 152-44	17,0	1450	21,1	16,5	15,7	14,2	12,7	11,6	10,1	8,3	6,6	4,8			DN 150	100	40
FDLV 152-43	20,6	1450	24,0	19,0	18,2	16,6	15,0	13,8	12,3	10,3	8,4	6,6	3,7		DN 150	100	40
FDLV 152-42	24,7	1450	27,1	21,8	21,0	19,2	17,5	16,3	14,6	12,5	10,5	8,5			DN 150	100	40
FDLV 153-41	29,0	1450	30,4	24,8	23,8	22,0	20,2	18,9	17,1	14,9	12,7	10,6			DN 150	100	40
FDLV 151-62	10,5	950	13,6	10,6	10,0	9,0	7,8	7,0	5,8	4,3	2,7	1,1			DN 150	100	40
FDLV 151-61	14,2	950	16,7	13,4	12,8	11,6	10,4	9,4	8,2	6,5	4,8	3,1			DN 150	100	40

PERFORMANCES MEASURED WITH PURE WATER AT 20°C

FDLV_B_TH

**FDLV SERIES
OPERATING CHARACTERISTICS AT 50 Hz**

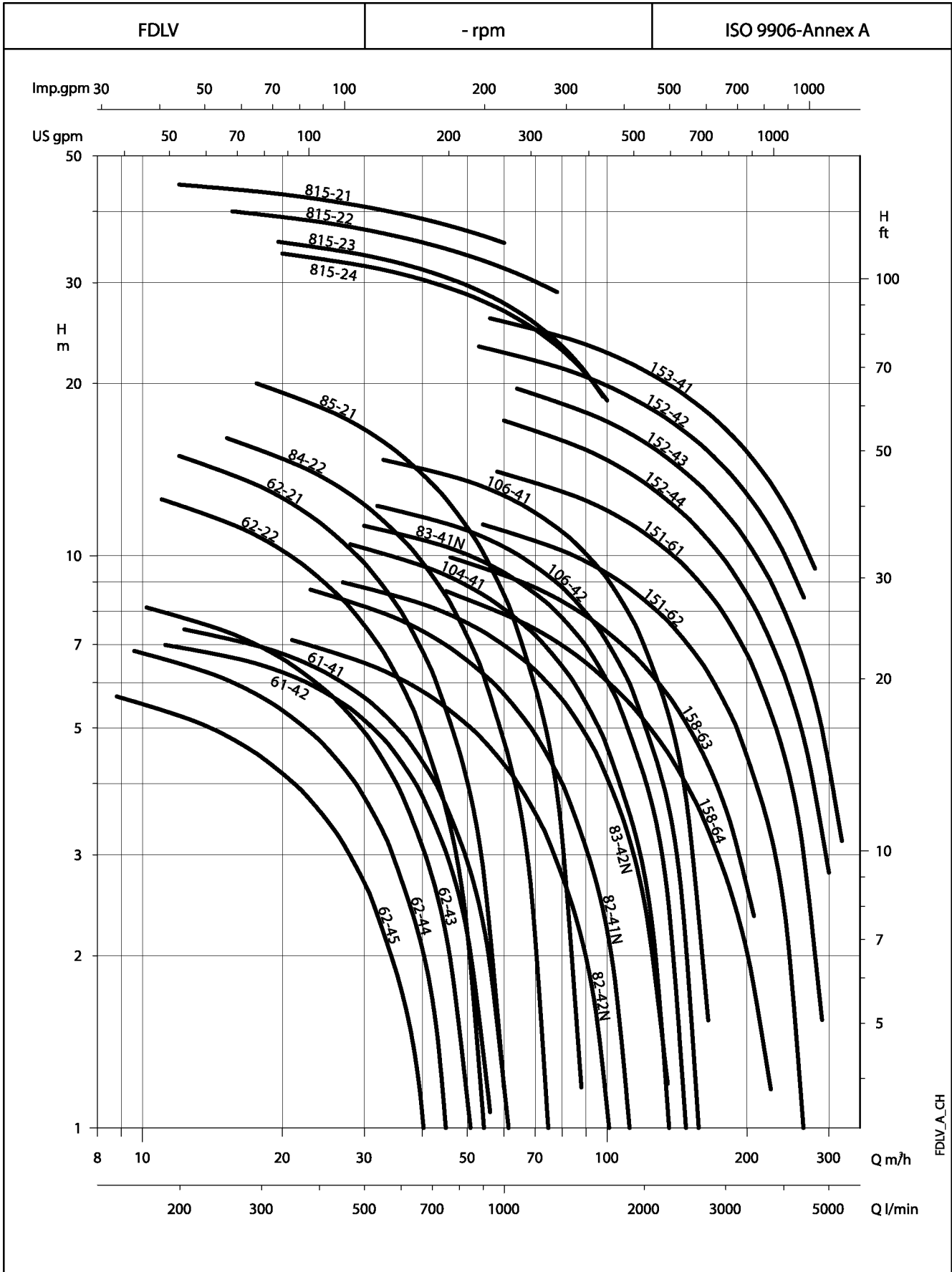

FDLV SERIES ELECTRICAL DATA (50 Hz)

PUMP TYPE	ABSORBED POWER*	rpm	ABSORBED CURRENT In(A)			STARTING CURRENT Isp(A)		ELECTRIC CABLE TYPE	STATOR THERMAL PROTECTION**	WATER SENSOR IN OIL CHAMBER**
			220-240 V	380-415 V		220-240 V	380-415 V			
			Δ	Y	Δ					
FDLV 62-22	3,2	2850	9,7	5,6		56,2	32,48	4G2,5	NO	NO
FDLV 62-21	3,4	2850	10,4	6		60,2	34,8	4G2,5	NO	NO
FDLV 84-22	4,5	2850	13,7		7,9	88,8	51,35	12G1,5	YES	YES
FDLV 85-21	6,2	2850	17,3		10	112,5	65	12G1,5	YES	YES
FDLV 815-24	18	2850	57,1		33	428,2	247,5	10G4	YES	YES
FDLV 815-23	18	2850	57,1		33	428,2	247,5	10G4	YES	YES
FDLV 815-22	18	2850	57,1		33	428,2	247,5	10G4	YES	YES
FDLV 815-21	18	2850	57,1		33	428,2	247,5	10G4	YES	YES
FDLV 62-45	1,1	1450	4,2	2,4		16,6	9,6	4G2,5	NO	NO
FDLV 62-44	1,3	1450	4,5	2,6		18,0	10,4	4G2,5	NO	NO
FDLV 62-43	1,6	1450	5,0	2,9		23,1	13,34	4G2,5	NO	NO
FDLV 61-42	1,5	1450	4,8	2,8		19,4	11,2	4G2,5	NO	NO
FDLV 61-41	1,6	1450	5,0	2,9		20,1	11,6	4G2,5	NO	NO
FDLV 82-42N	2,4	1450	8,3	4,8		38,2	22,08	4G2,5	NO	NO
FDLV 82-41N	3	1450	9,2	5,3		42,2	24,38	4G2,5	NO	NO
FDLV 83-42N	3,6	1450	12,8		7,4	66,6	38,48	12G1,5	YES	YES
FDLV 83-41N	4,6	1450	14,7		8,5	76,5	44,2	12G1,5	YES	YES
FDLV 104-41	4,5	1450	14,2		8,2	73,8	42,64	12G1,5	YES	YES
FDLV 106-42	5,4	1450	16,4		9,5	92,0	53,2	12G2,5	YES	YES
FDLV 106-41	6,8	1450	20,8		12	116,3	67,2	12G2,5	YES	YES
FDLV 152-44	17	1450	53,6		31	337,9	195,3	10G4	YES	YES
FDLV 152-43	20,6	1450	64,9		37,5	408,7	236,25	10G4	YES	YES
FDLV 152-42	24,7	1450	77,9		45	490,5	283,5	10G4	YES	YES
FDLV 153-41	29	1450	93,4		54	588,5	340,2	10G4	YES	YES
FDLV 158-64	6,6	950	22,0		12,7	138,4	80,01	10G4	YES	YES
FDLV 158-63	7,9	950	26,5		15,3	166,8	96,39	10G4	YES	YES
FDLV 151-62	10,5	950	32,0		18,5	166,4	96,2	10G4	YES	YES
FDLV 151-61	14,2	950	43,3		25	224,9	130	10G4	YES	YES

*Maximum values within the operating range

Fdlv-2p-4p-6p50_a_te

**Featured in the standard version

**FDLV SERIES
OPERATING CHARACTERISTICS AT 2850 rpm 50 Hz**

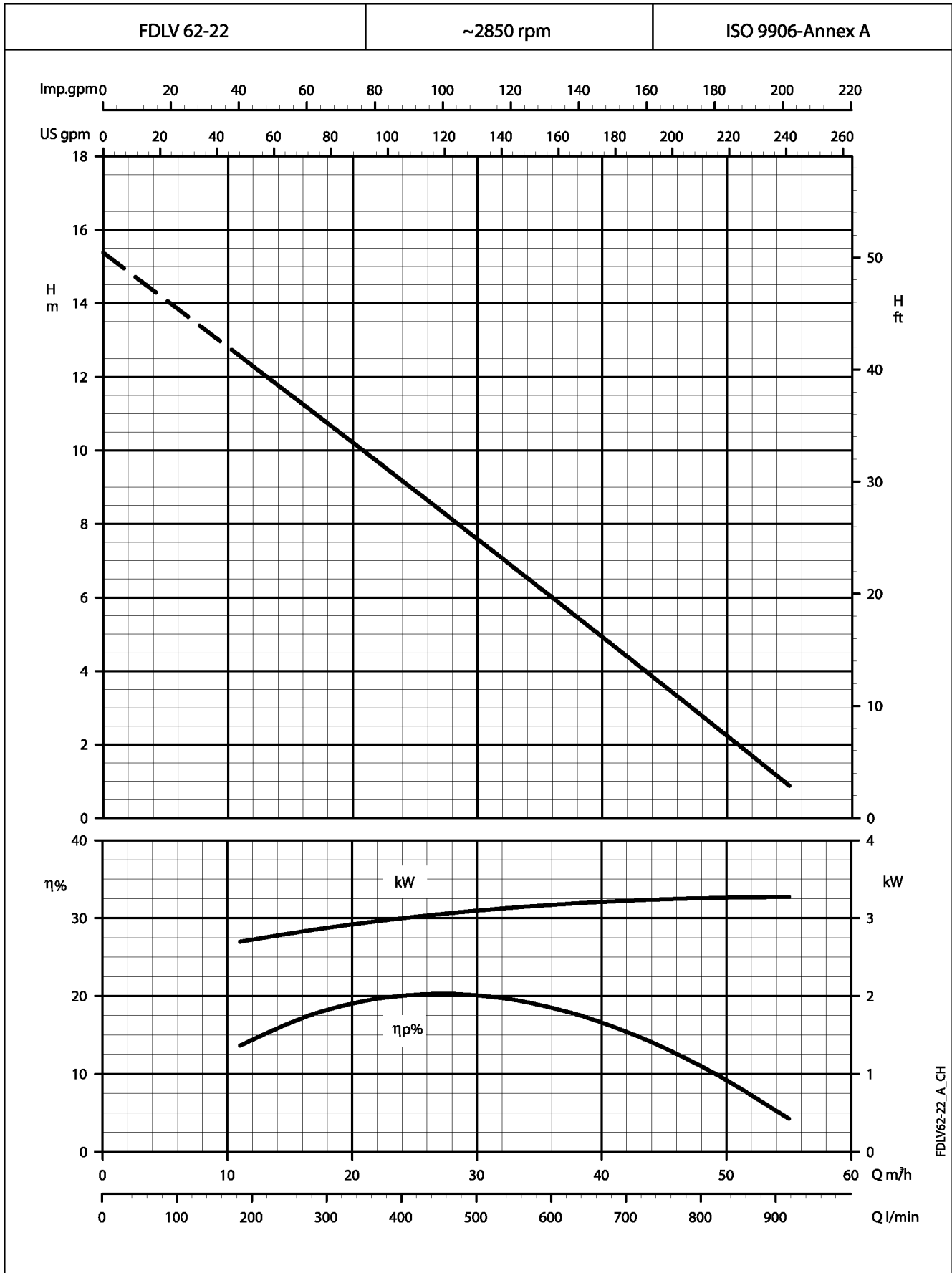

These performances are valid for liquids with density $\rho = 1.0 \text{ kg/dm}^3$ and kinematic viscosity $\nu = 1 \text{ mm}^2/\text{s}$.

**FDLV SERIES
OPERATING CHARACTERISTICS AT 2850 rpm 50 Hz**

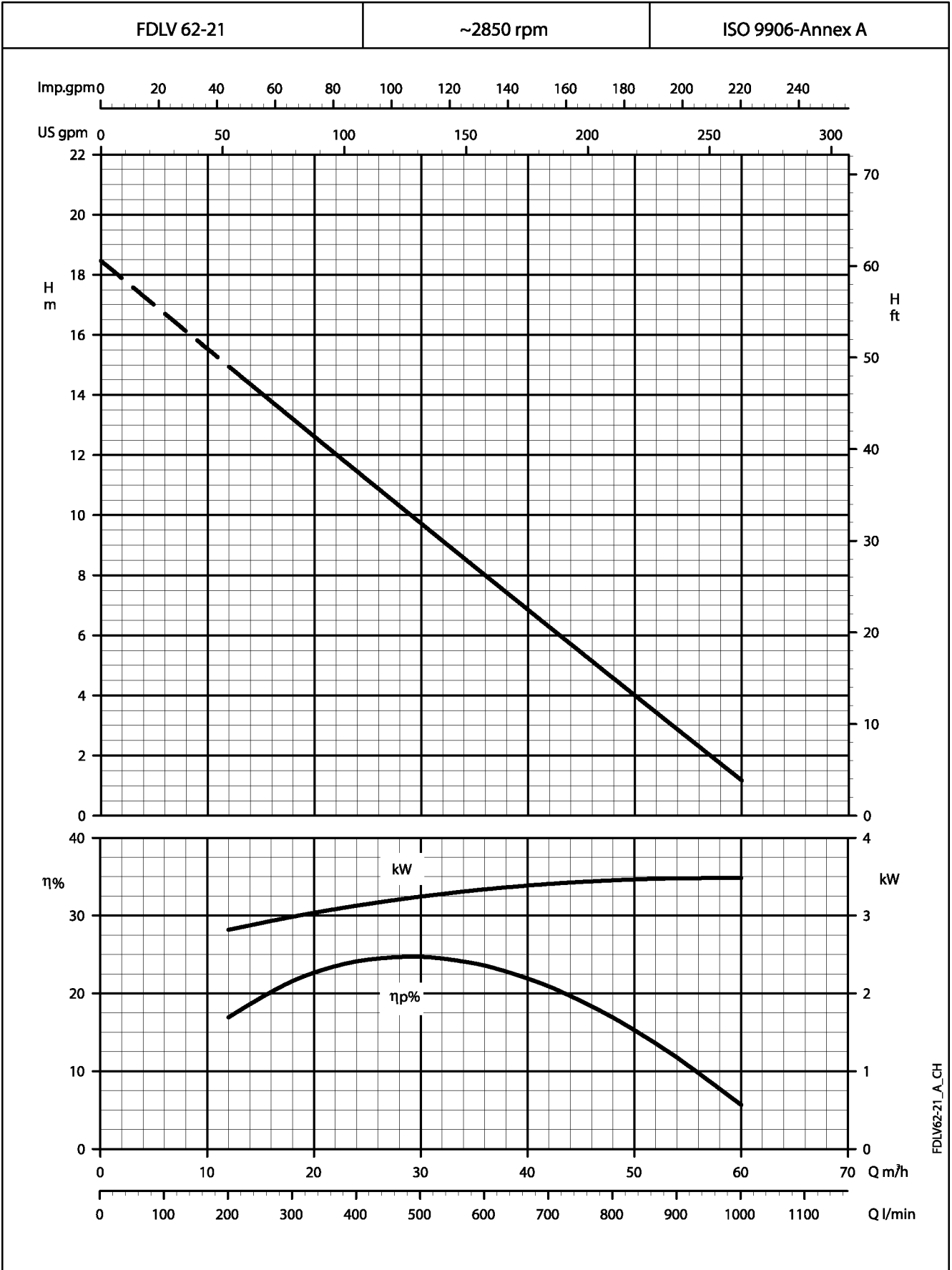

These performances are valid for liquids with density $\rho = 1.0 \text{ kg/dm}^3$ and kinematic viscosity $\gamma = 1 \text{ mm}^2/\text{s}$.

**FDLV SERIES
OPERATING CHARACTERISTICS AT 2850 rpm 50 Hz**

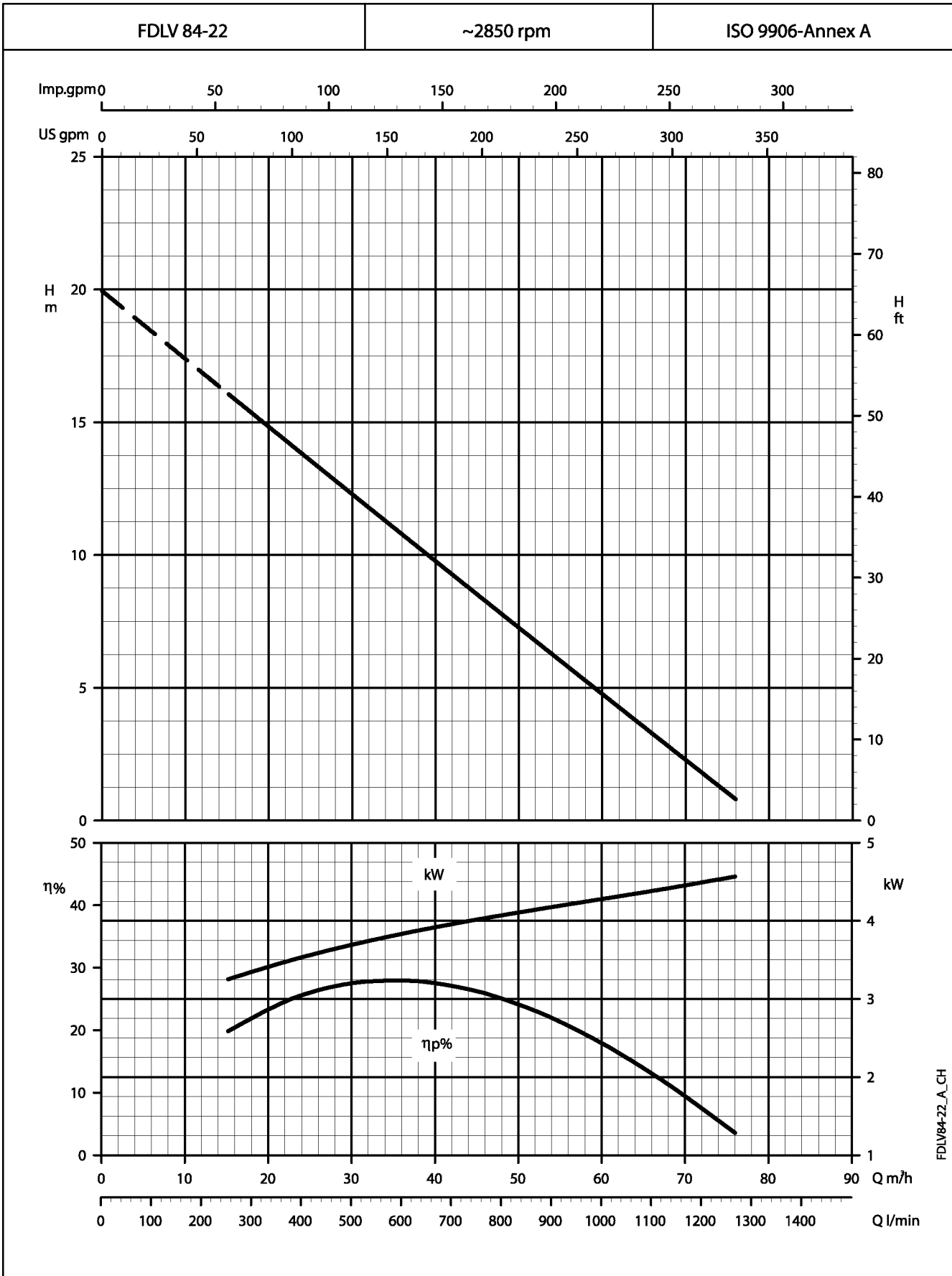

These performances are valid for liquids with density $\rho = 1.0 \text{ kg/dm}^3$ and kinematic viscosity $\gamma = 1 \text{ mm}^2/\text{s}$.

**FDLV SERIES
OPERATING CHARACTERISTICS AT 2850 rpm 50 Hz**

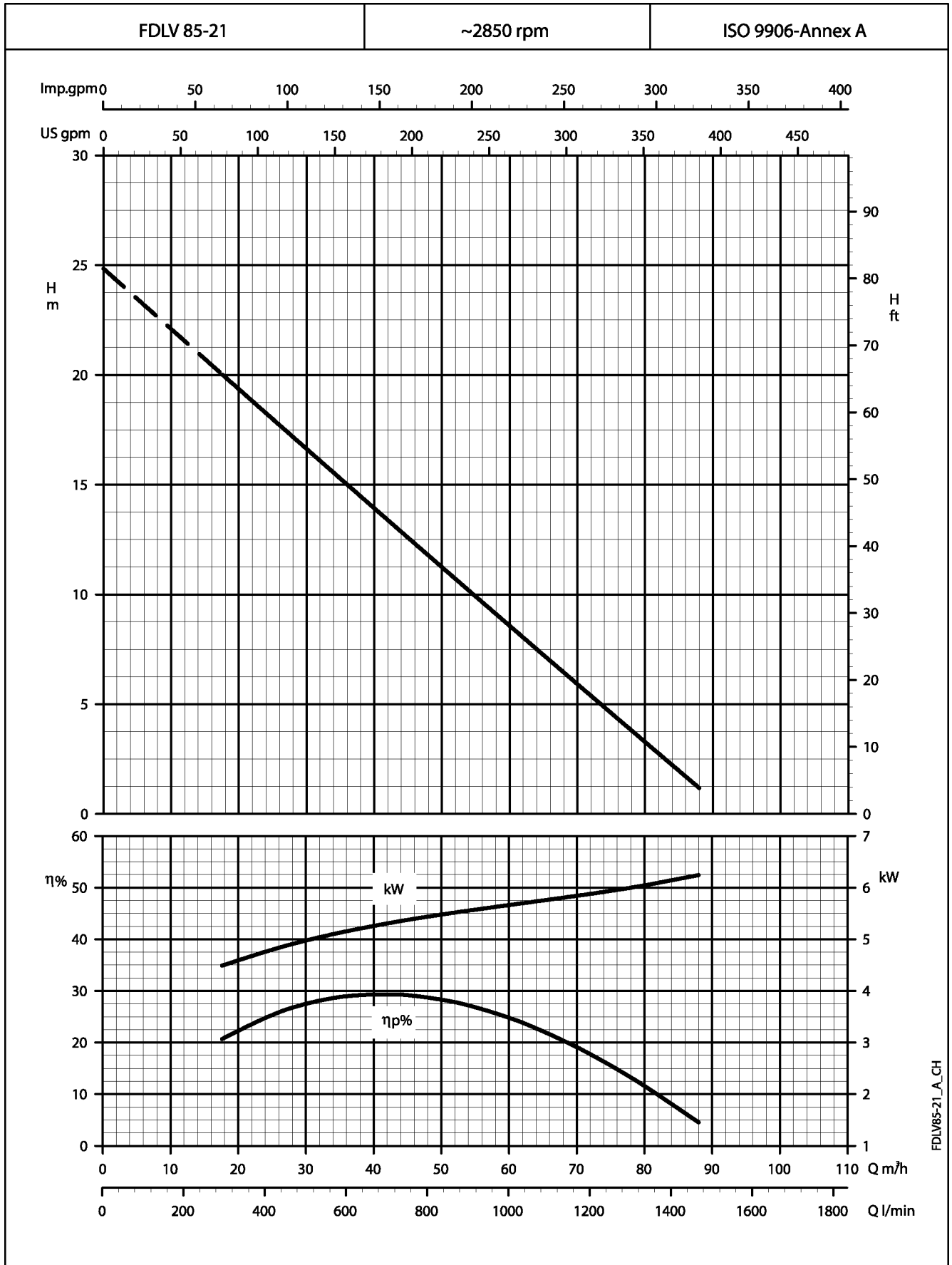

These performances are valid for liquids with density $\rho = 1.0 \text{ kg/dm}^3$ and kinematic viscosity $\gamma = 1 \text{ mm}^2/\text{s}$.

FDLV85-21_A_CH

**FDLV SERIES
OPERATING CHARACTERISTICS AT 2850 rpm 50 Hz**

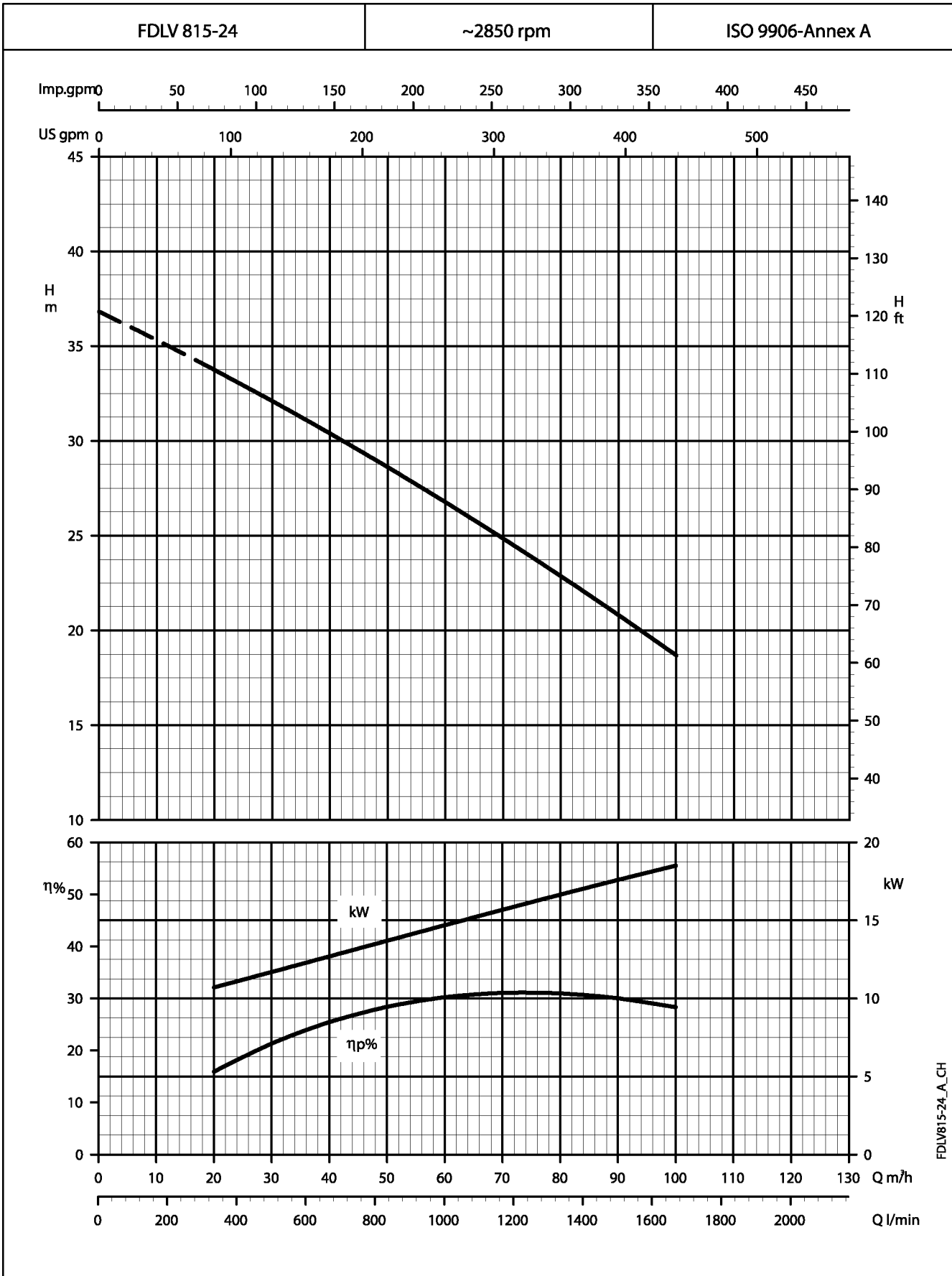

These performances are valid for liquids with density $\rho = 1.0 \text{ kg/dm}^3$ and kinematic viscosity $\gamma = 1 \text{ mm}^2/\text{s}$.

**FDLV SERIES
OPERATING CHARACTERISTICS AT 2850 rpm 50 Hz**

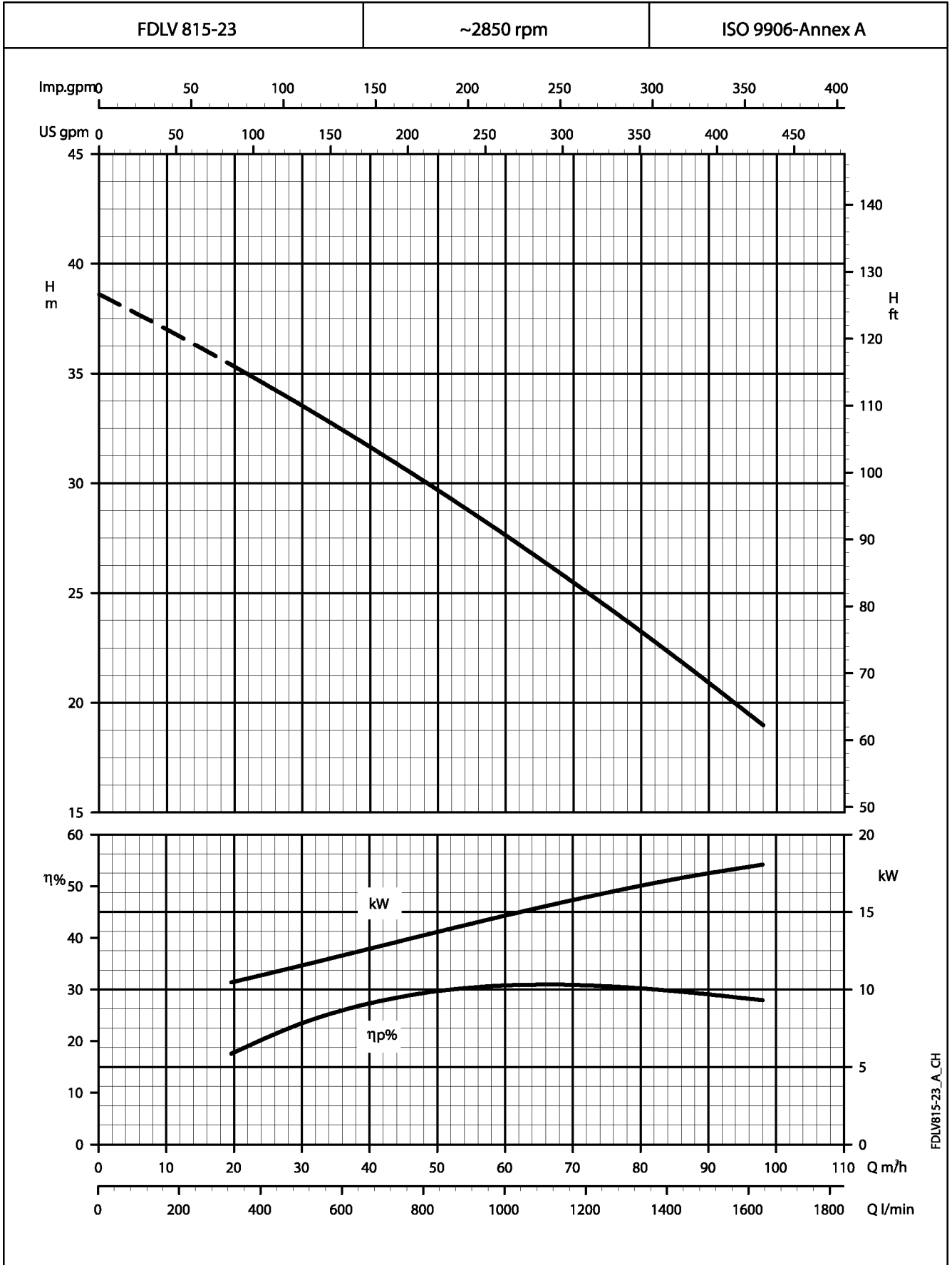

These performances are valid for liquids with density $\rho = 1.0 \text{ kg/dm}^3$ and kinematic viscosity $\gamma = 1 \text{ mm}^2/\text{s}$.

**FDLV SERIES
OPERATING CHARACTERISTICS AT 2850 rpm 50 Hz**

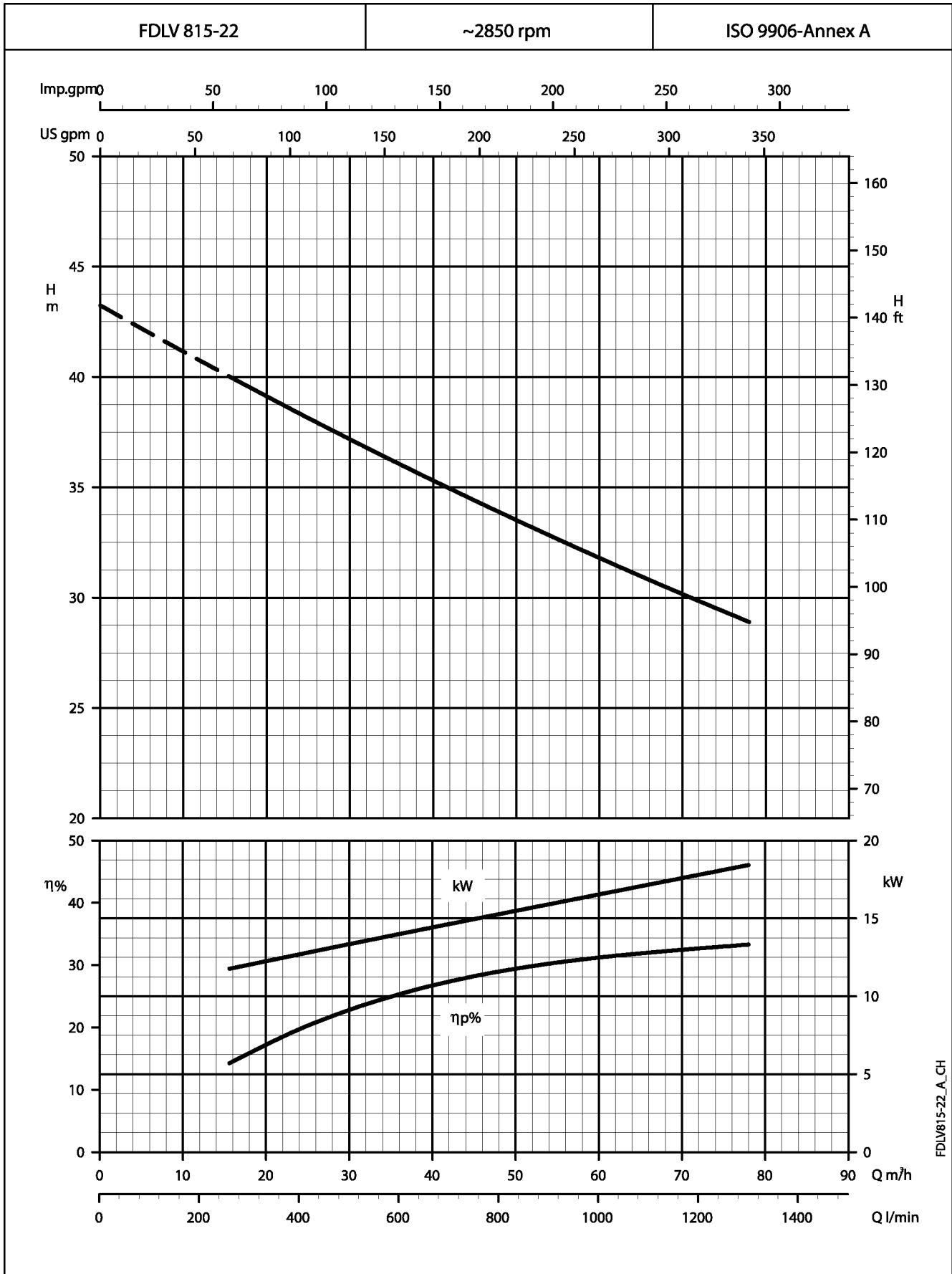

These performances are valid for liquids with density $\rho = 1.0 \text{ kg/dm}^3$ and kinematic viscosity $\gamma = 1 \text{ mm}^2/\text{s}$.

**FDLV SERIES
OPERATING CHARACTERISTICS AT 2850 rpm 50 Hz**

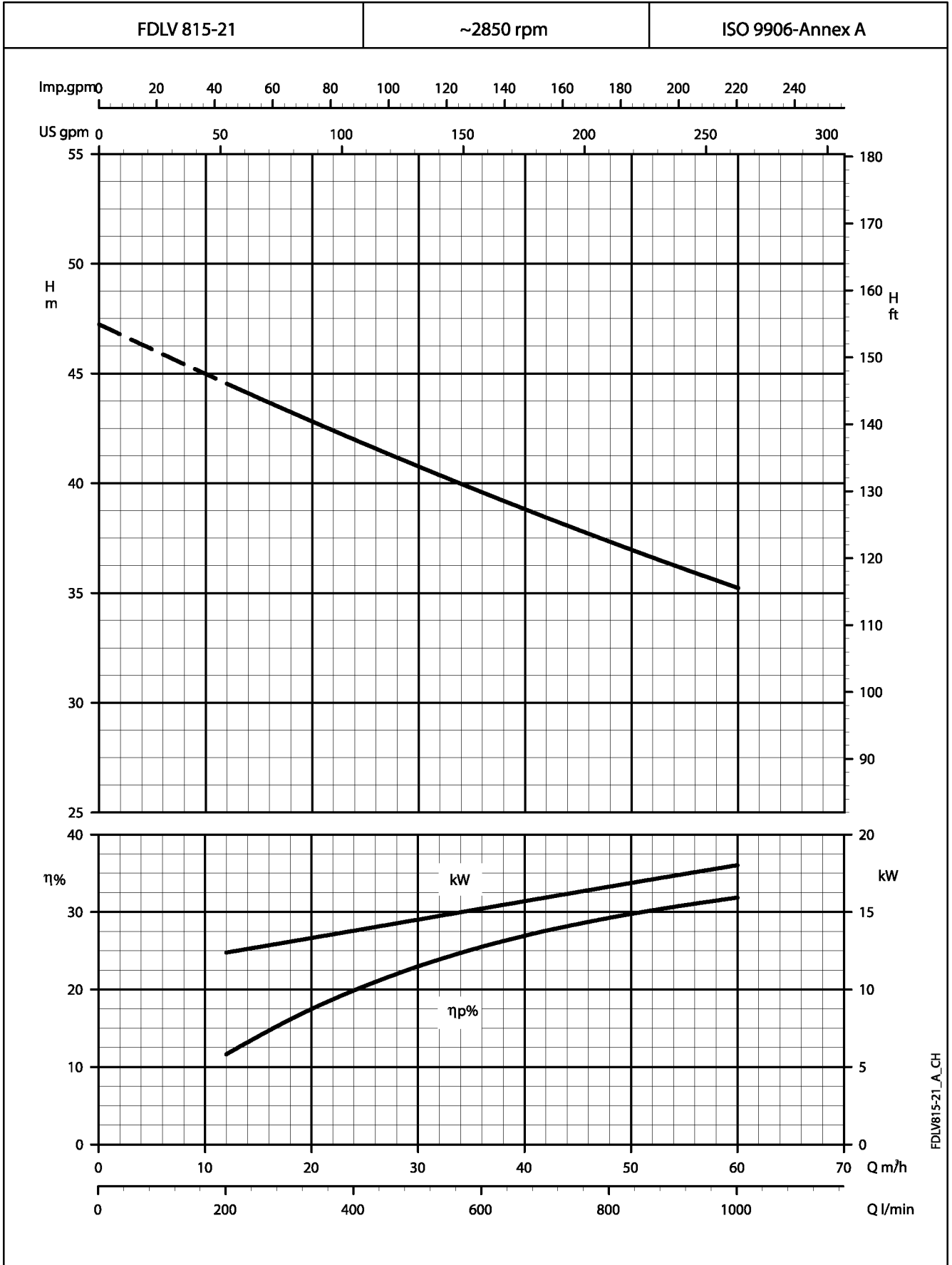

These performances are valid for liquids with density $\rho = 1.0 \text{ kg/dm}^3$ and kinematic viscosity $\gamma = 1 \text{ mm}^2/\text{s}$.

**FDLV SERIES
OPERATING CHARACTERISTICS AT 1450 rpm 50 Hz**

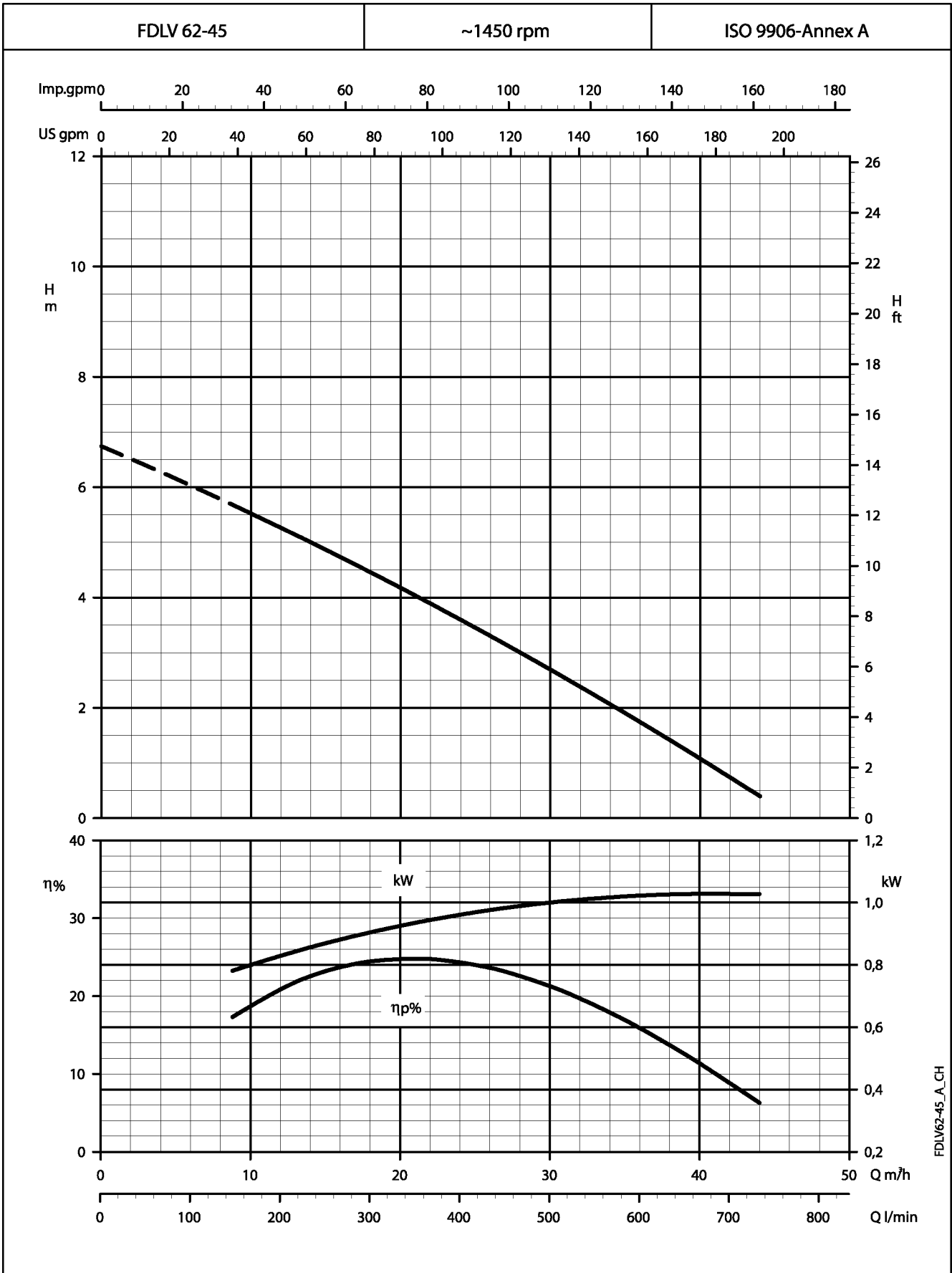

These performances are valid for liquids with density $\rho = 1.0 \text{ kg/dm}^3$ and kinematic viscosity $\gamma = 1 \text{ mm}^2/\text{s}$.

**FDLV SERIES
OPERATING CHARACTERISTICS AT 1450 rpm 50 Hz**

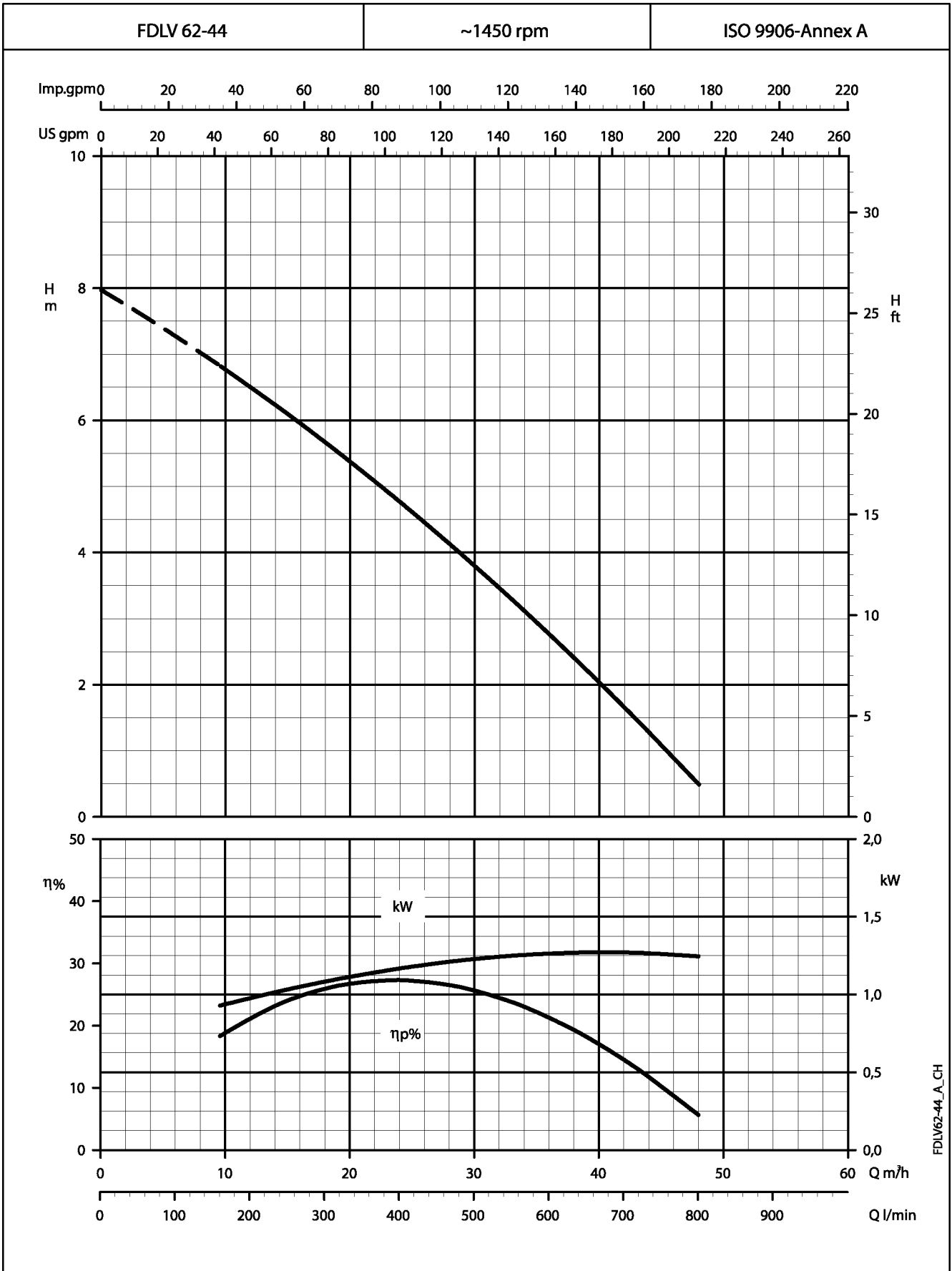

These performances are valid for liquids with density $\rho = 1.0 \text{ kg/dm}^3$ and kinematic viscosity $\gamma = 1 \text{ mm}^2/\text{s}$.

**FDLV SERIES
OPERATING CHARACTERISTICS AT 1450 rpm 50 Hz**

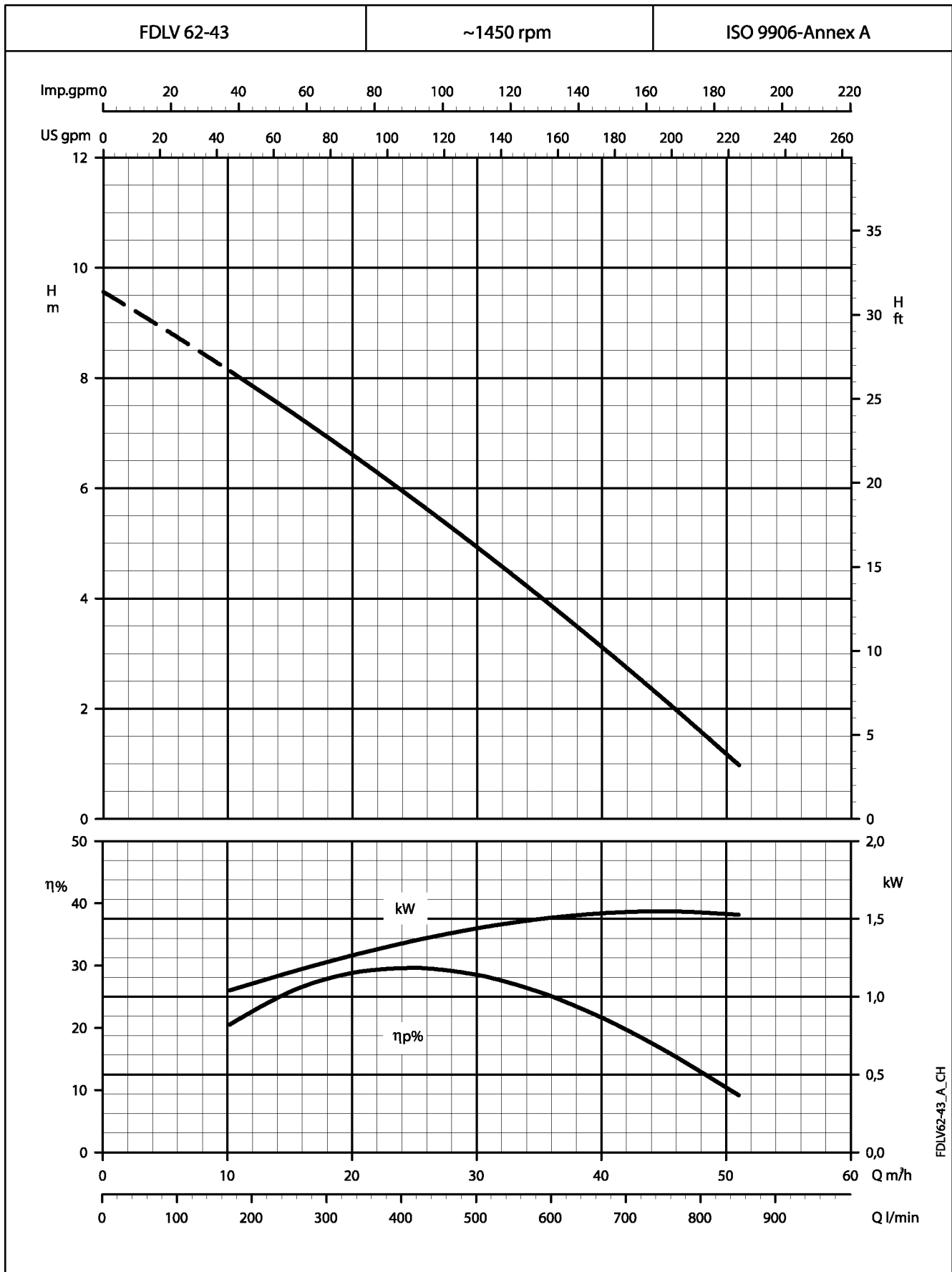

These performances are valid for liquids with density $\rho = 1.0 \text{ kg/dm}^3$ and kinematic viscosity $\nu = 1 \text{ mm}^2/\text{s}$.

**FDLV SERIES
OPERATING CHARACTERISTICS AT 1450 rpm 50 Hz**

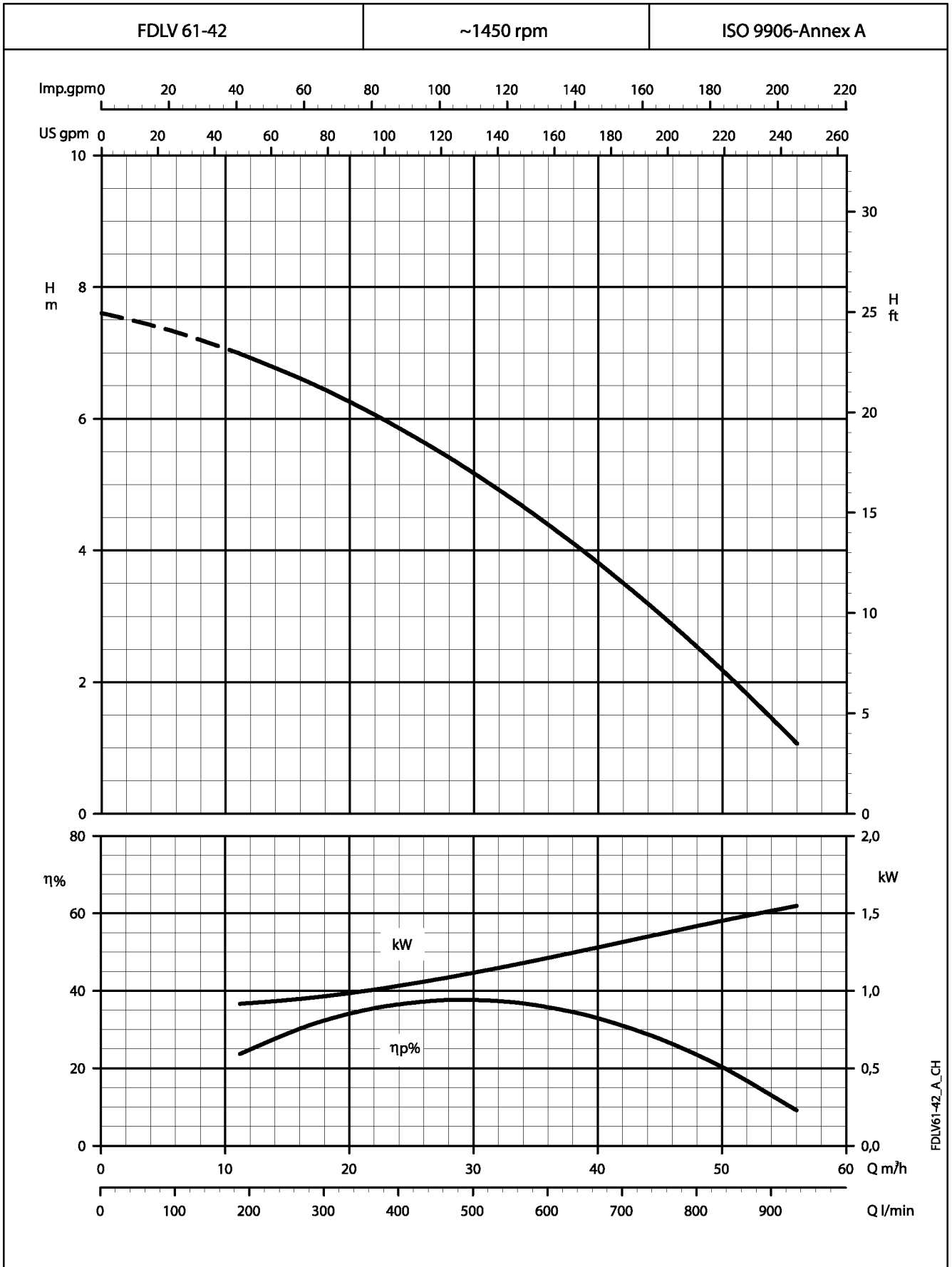

These performances are valid for liquids with density $\rho = 1.0 \text{ kg/dm}^3$ and kinematic viscosity $\gamma = 1 \text{ mm}^2/\text{s}$.

**FDLV SERIES
OPERATING CHARACTERISTICS AT 1450 rpm 50 Hz**

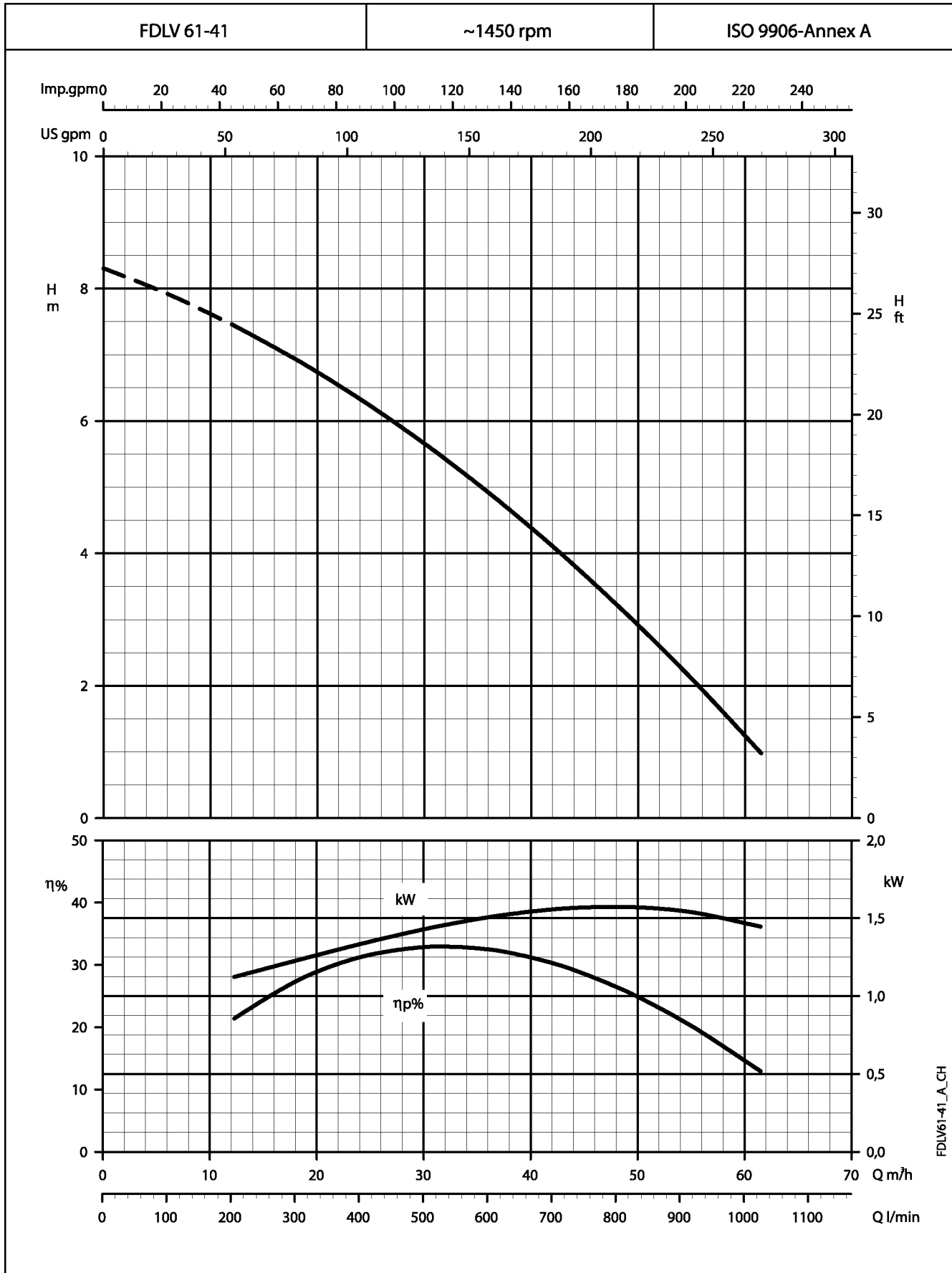

These performances are valid for liquids with density $\rho = 1.0 \text{ kg/dm}^3$ and kinematic viscosity $\nu = 1 \text{ mm}^2/\text{s}$.

**FDLV SERIES
OPERATING CHARACTERISTICS AT 1450 rpm 50 Hz**

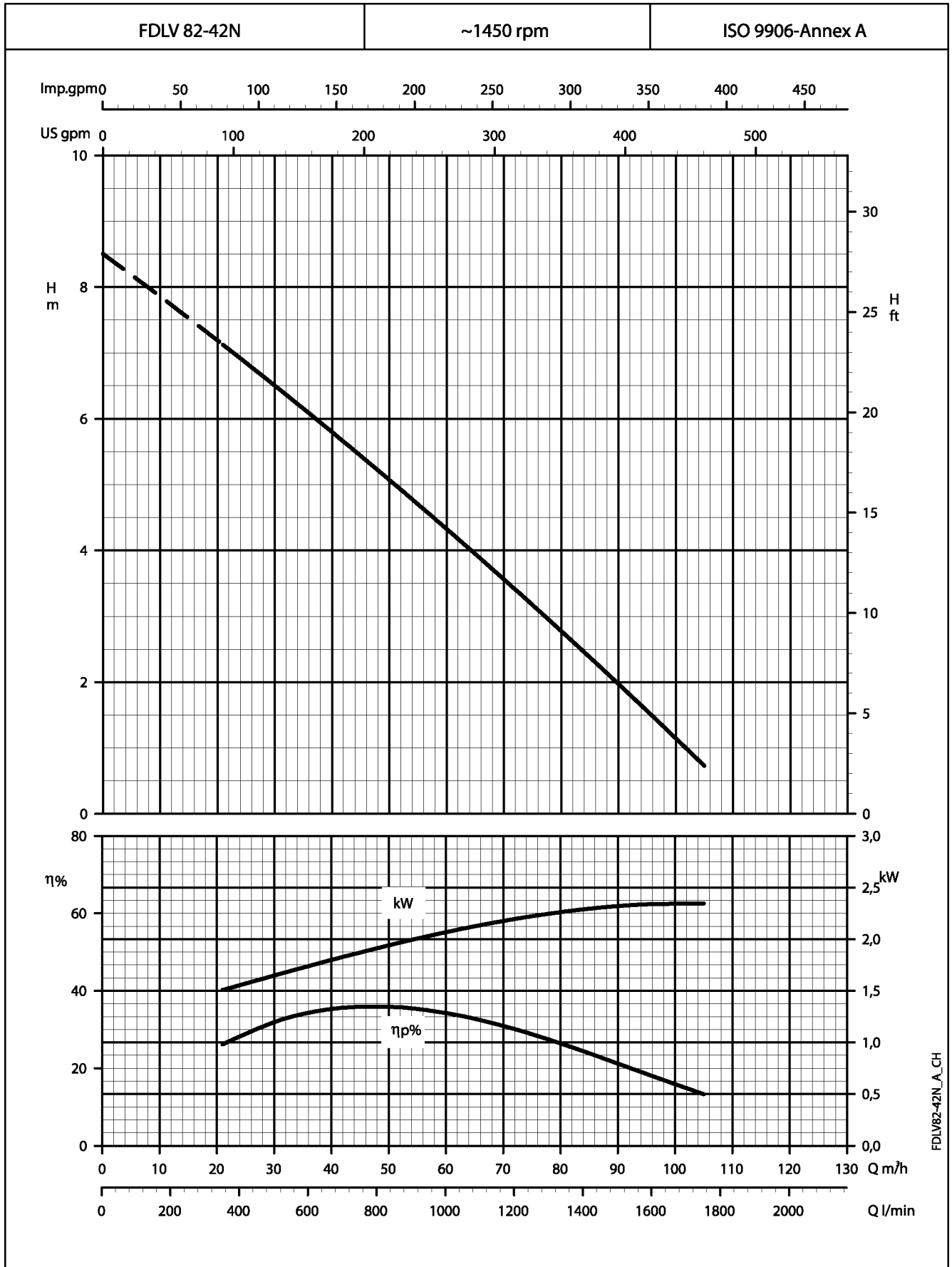

These performances are valid for liquids with density $\rho = 1.0 \text{ kg/dm}^3$ and kinematic viscosity $\gamma = 1 \text{ mm}^2/\text{s}$.

**FDLV SERIES
OPERATING CHARACTERISTICS AT 1450 rpm 50 Hz**

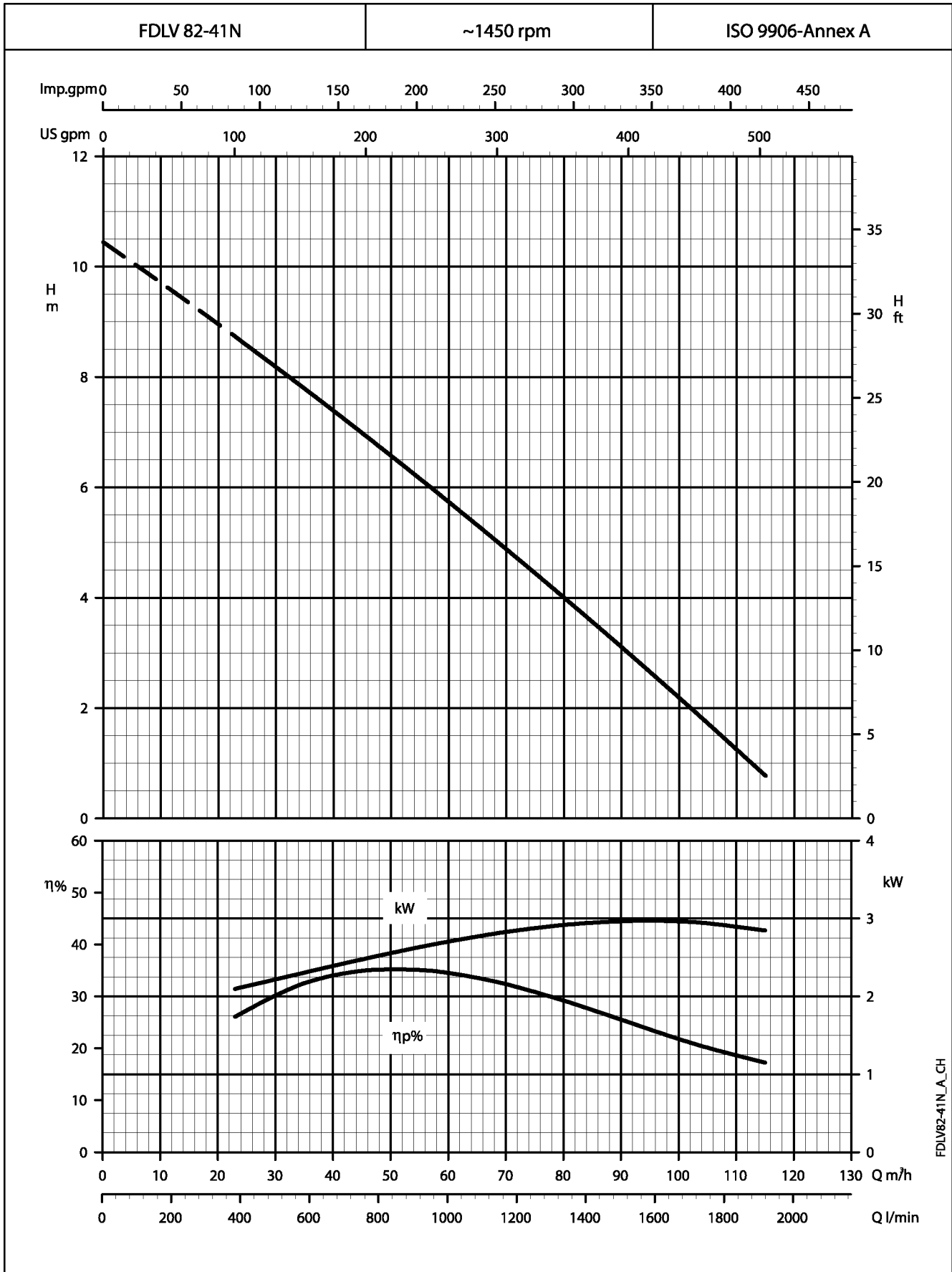

These performances are valid for liquids with density $\rho = 1.0 \text{ kg/dm}^3$ and kinematic viscosity $\gamma = 1 \text{ mm}^2/\text{s}$.

**FDLV SERIES
OPERATING CHARACTERISTICS AT 1450 rpm 50 Hz**

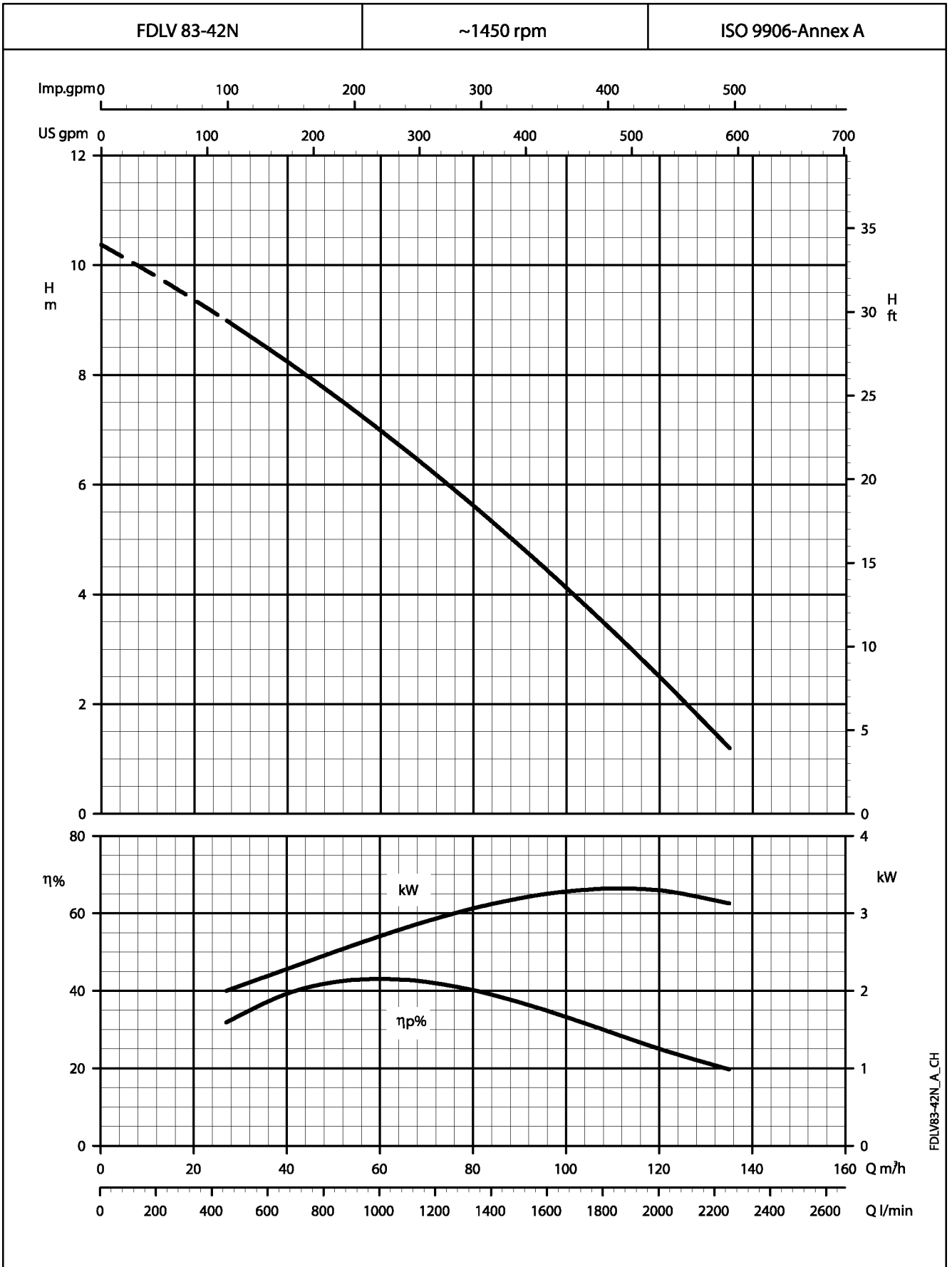

These performances are valid for liquids with density $\rho = 1.0 \text{ kg/dm}^3$ and kinematic viscosity $\gamma = 1 \text{ mm}^2/\text{s}$.

**FDLV SERIES
OPERATING CHARACTERISTICS AT 1450 rpm 50 Hz**

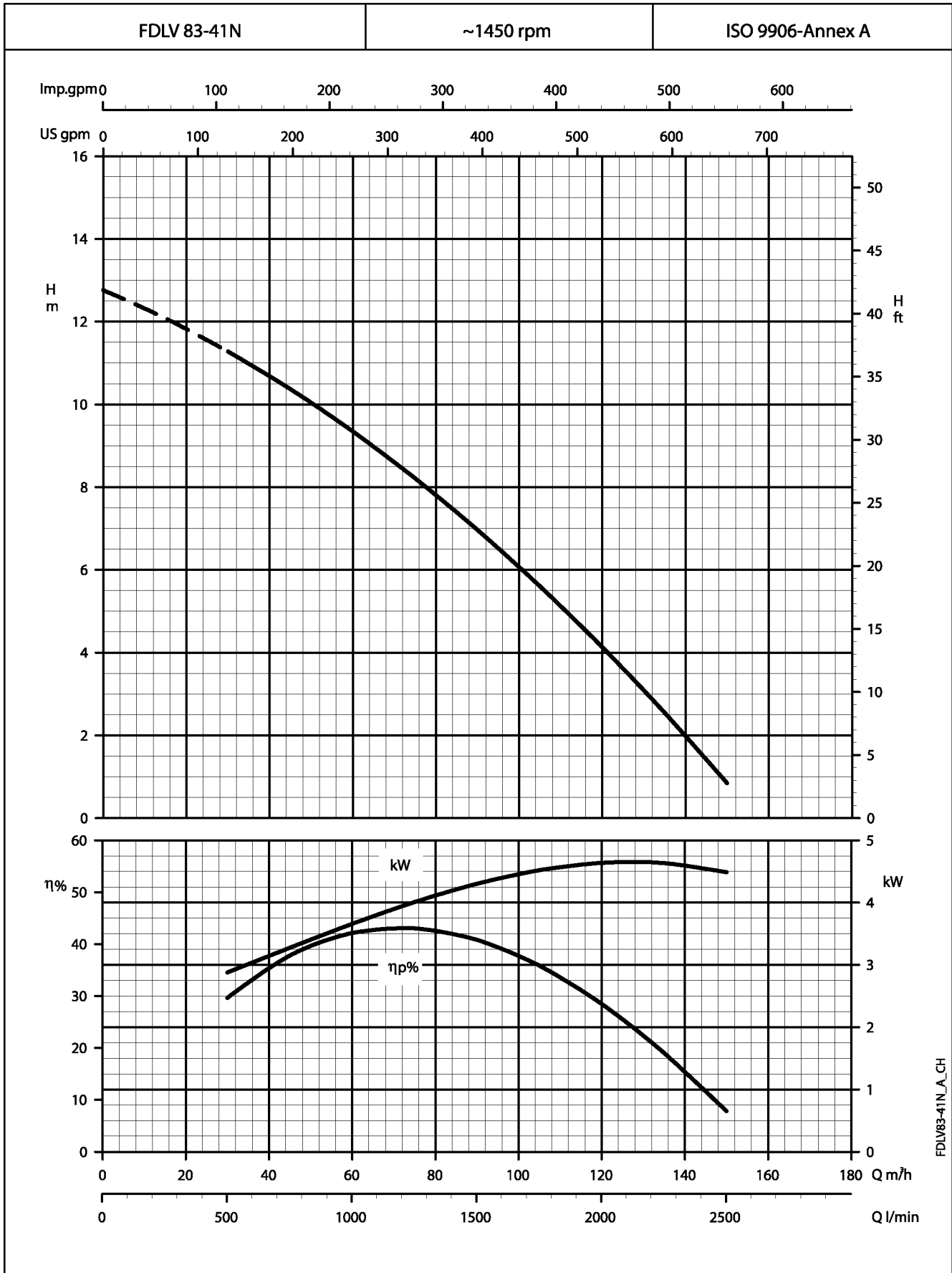

These performances are valid for liquids with density $\rho = 1.0 \text{ kg/dm}^3$ and kinematic viscosity $\gamma = 1 \text{ mm}^2/\text{s}$.

**FDLV SERIES
OPERATING CHARACTERISTICS AT 1450 rpm 50 Hz**

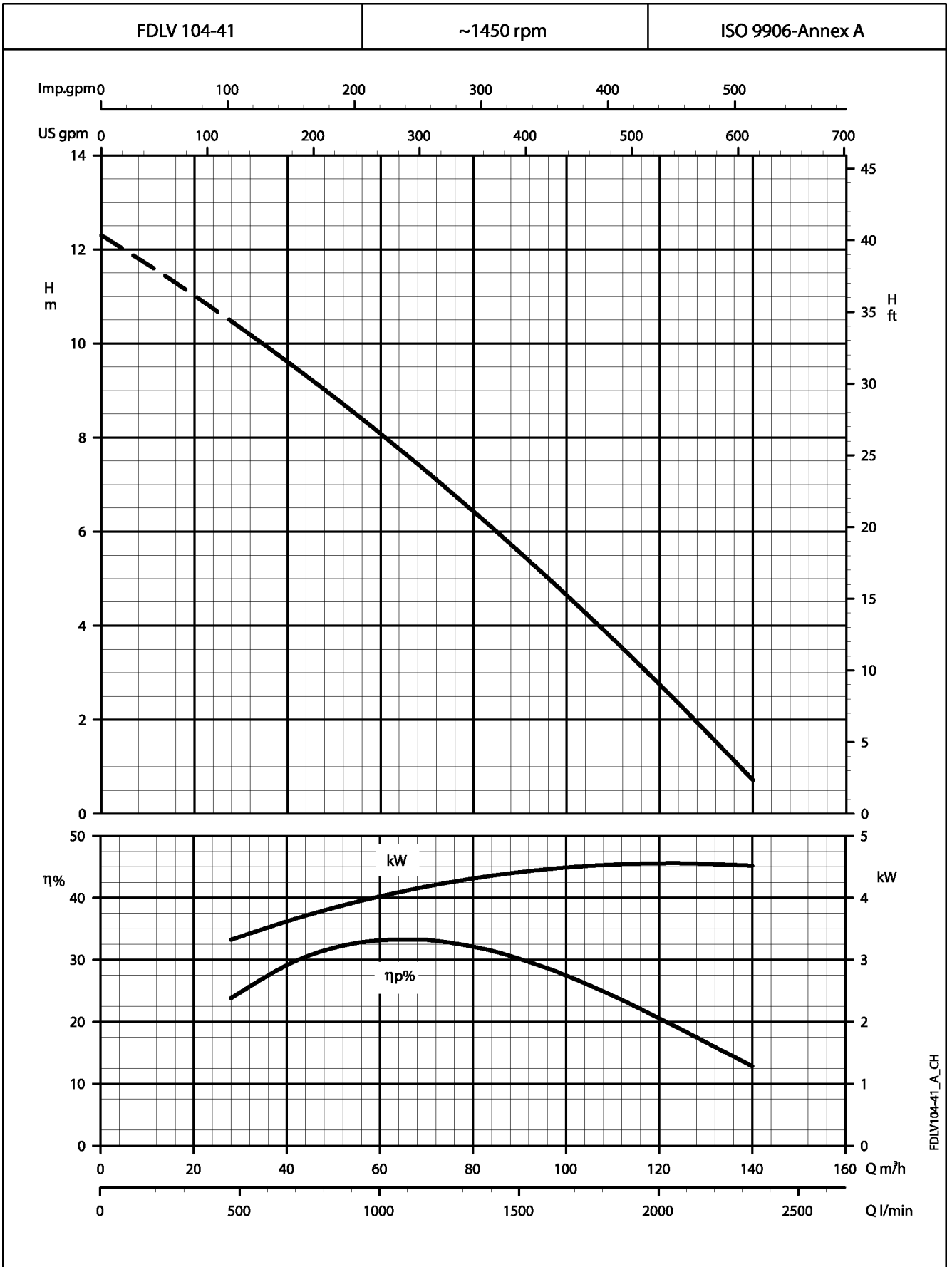

These performances are valid for liquids with density $\rho = 1.0 \text{ kg/dm}^3$ and kinematic viscosity $\gamma = 1 \text{ mm}^2/\text{s}$.

**FDLV SERIES
OPERATING CHARACTERISTICS AT 1450 rpm 50 Hz**

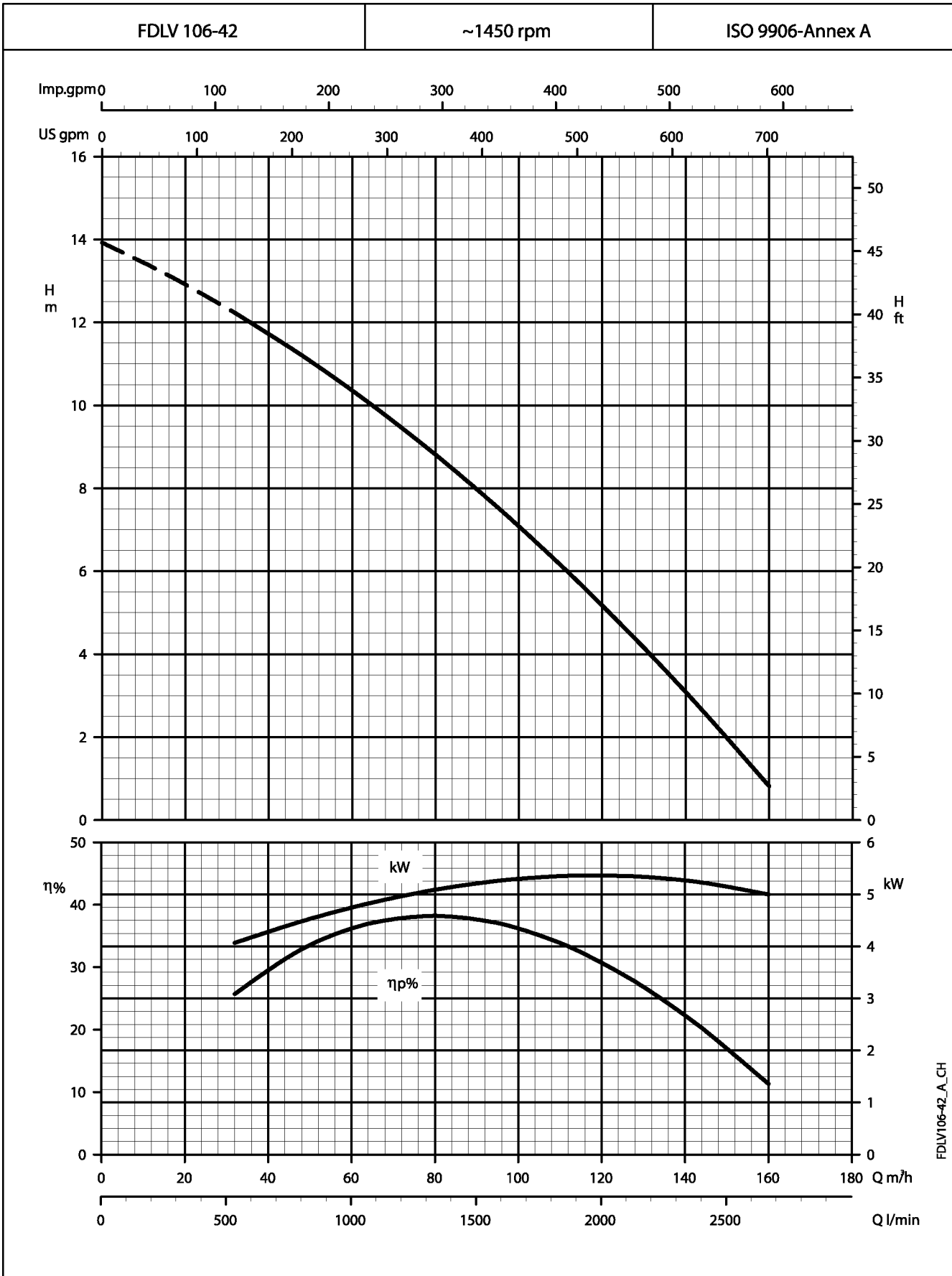

FDLV106-42_A_CH

These performances are valid for liquids with density $\rho = 1.0 \text{ kg/dm}^3$ and kinematic viscosity $\gamma = 1 \text{ mm}^2/\text{s}$.

**FDLV SERIES
OPERATING CHARACTERISTICS AT 1450 rpm 50 Hz**

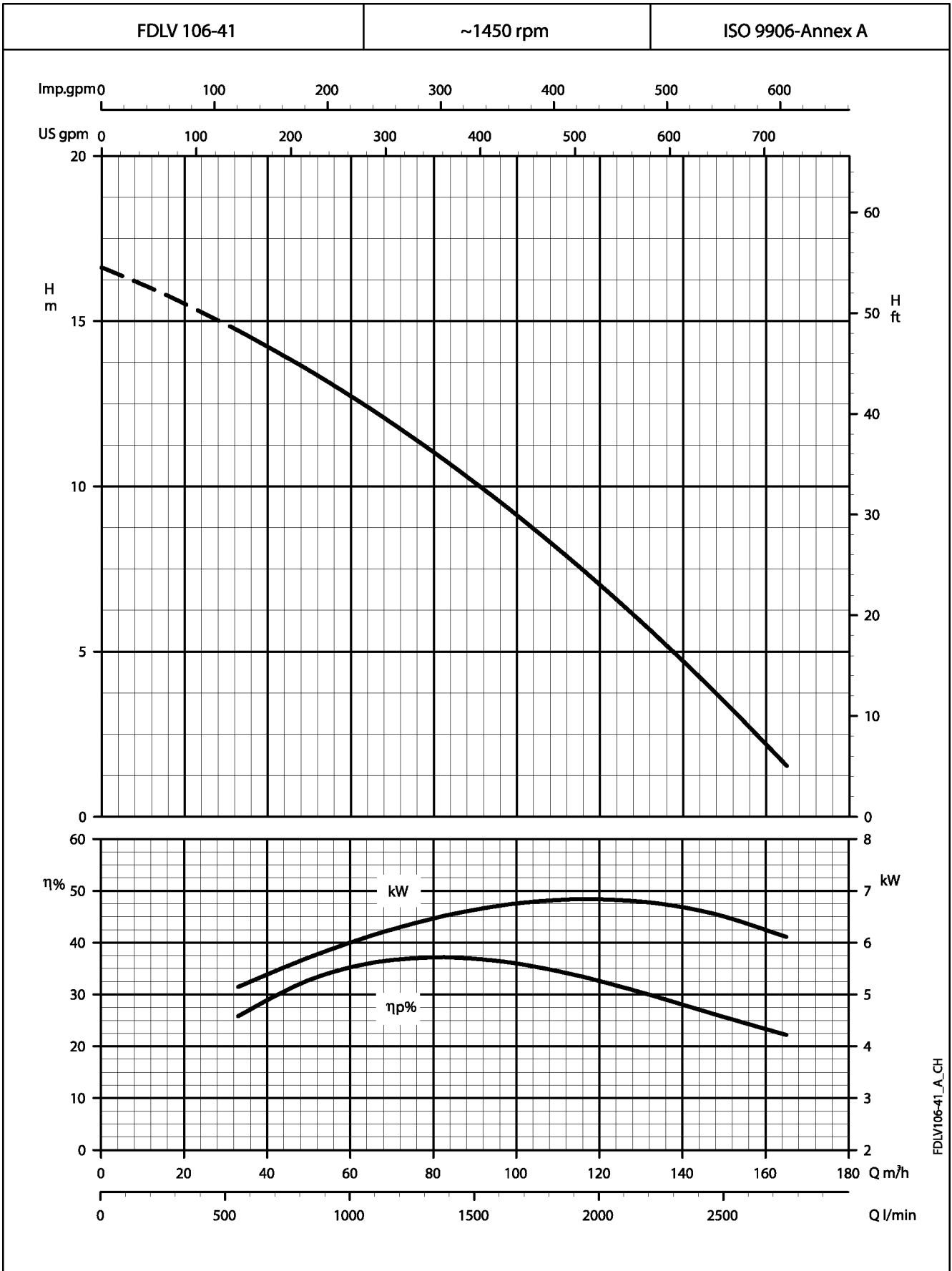

These performances are valid for liquids with density $\rho = 1.0 \text{ kg/dm}^3$ and kinematic viscosity $\gamma = 1 \text{ mm}^2/\text{s}$.

**FDLV SERIES
OPERATING CHARACTERISTICS AT 1450 rpm 50 Hz**

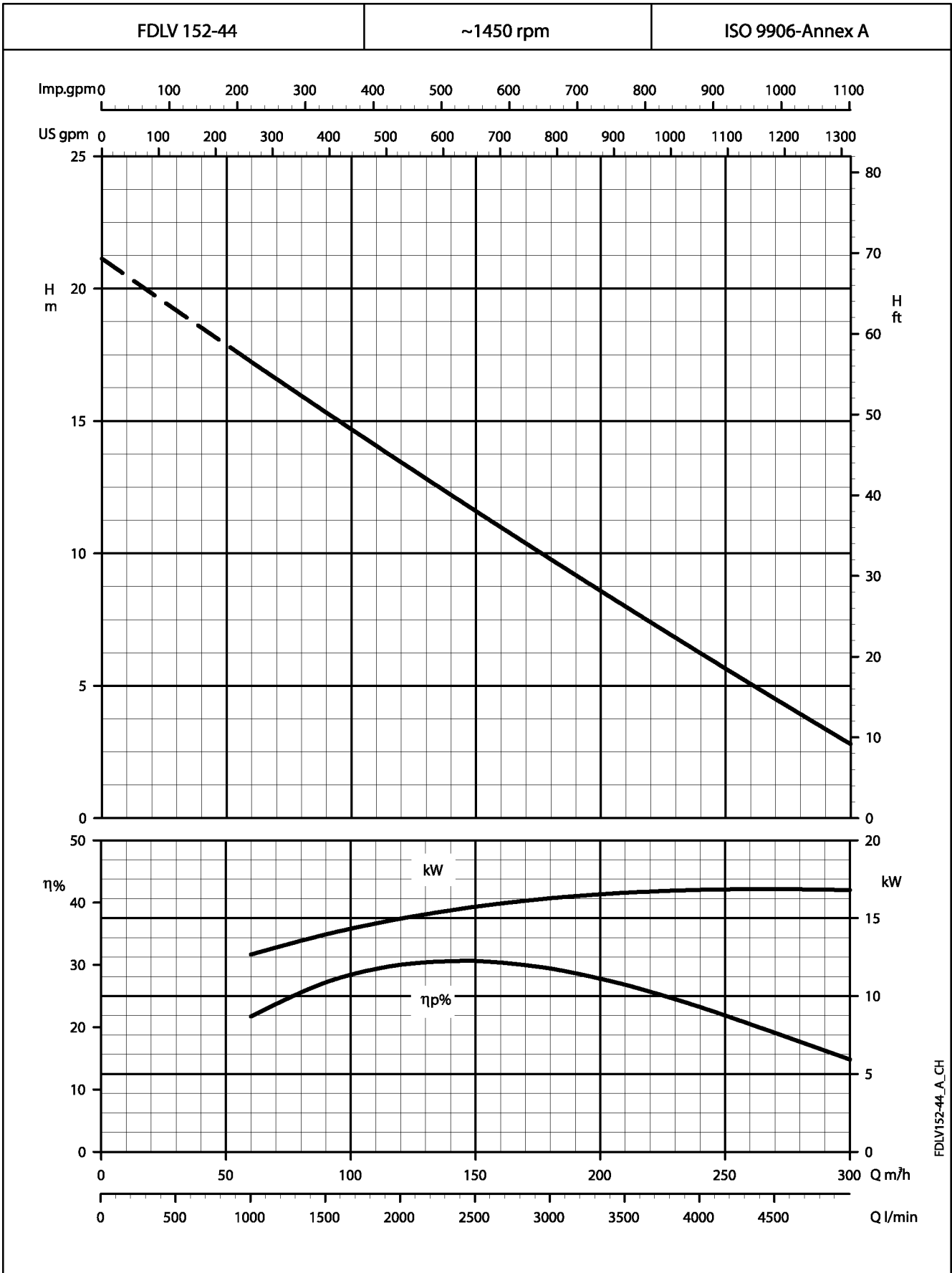

These performances are valid for liquids with density $\rho = 1.0 \text{ kg/dm}^3$ and kinematic viscosity $\gamma = 1 \text{ mm}^2/\text{s}$.

**FDLV SERIES
OPERATING CHARACTERISTICS AT 1450 rpm 50 Hz**

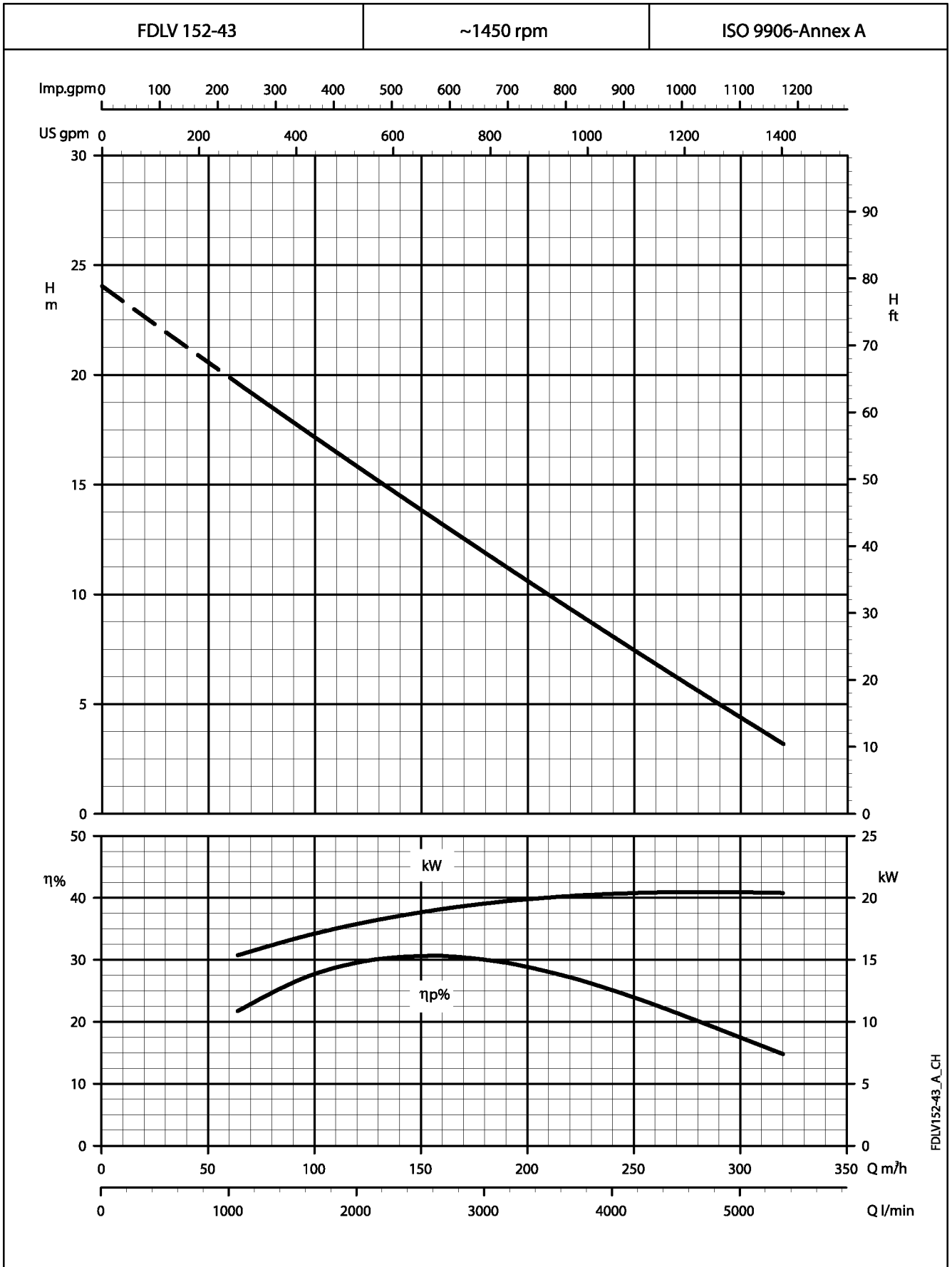

These performances are valid for liquids with density $\rho = 1.0 \text{ kg/dm}^3$ and kinematic viscosity $\gamma = 1 \text{ mm}^2/\text{s}$.

**FDLV SERIES
OPERATING CHARACTERISTICS AT 1450 rpm 50 Hz**

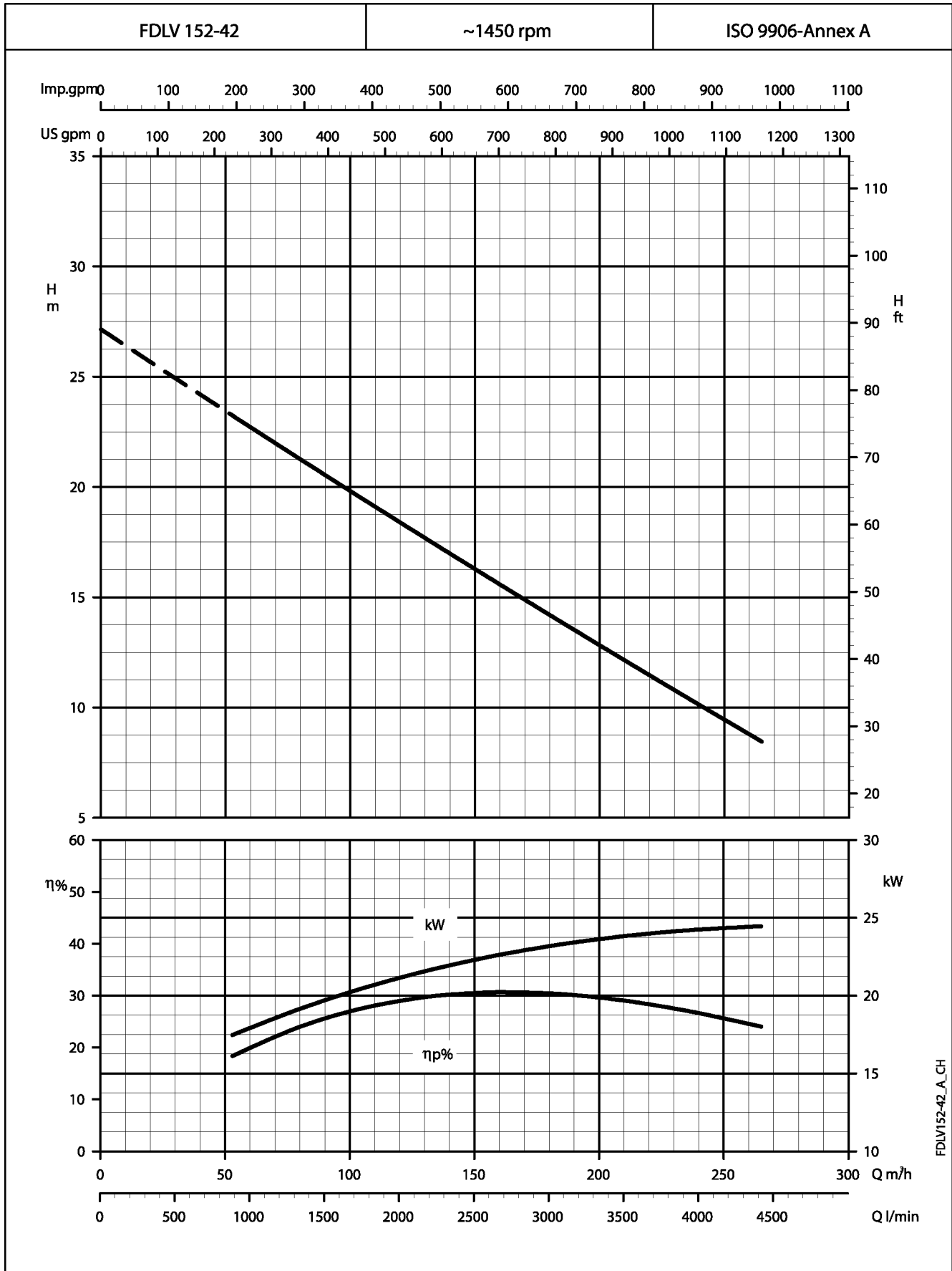

These performances are valid for liquids with density $\rho = 1.0 \text{ kg/dm}^3$ and kinematic viscosity $\nu = 1 \text{ mm}^2/\text{s}$.

**FDLV SERIES
OPERATING CHARACTERISTICS AT 1450 rpm 50 Hz**

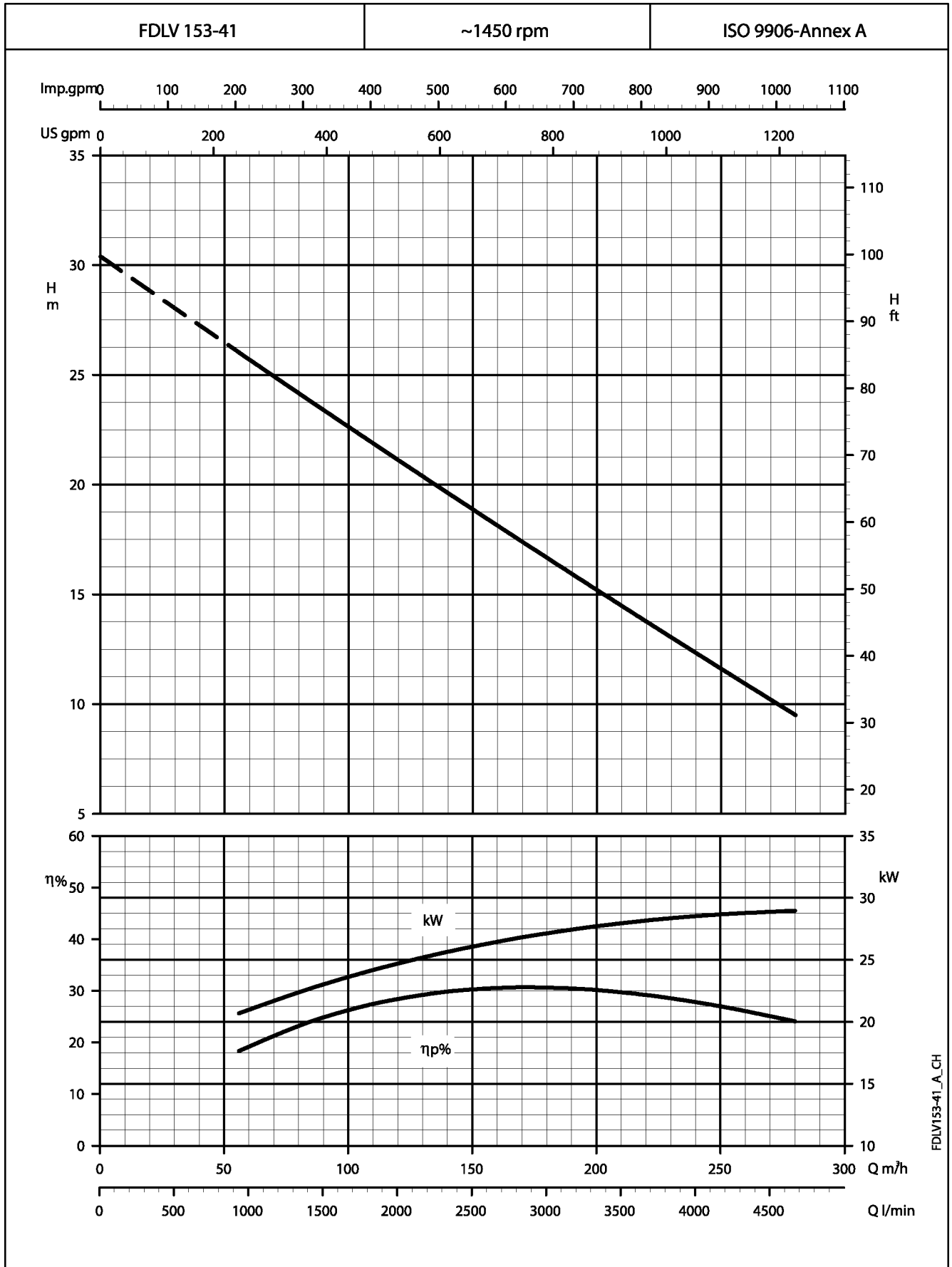

These performances are valid for liquids with density $\rho = 1.0 \text{ kg/dm}^3$ and kinematic viscosity $\gamma = 1 \text{ mm}^2/\text{s}$.

**FDLV SERIES
OPERATING CHARACTERISTICS AT 950 rpm 50 Hz**

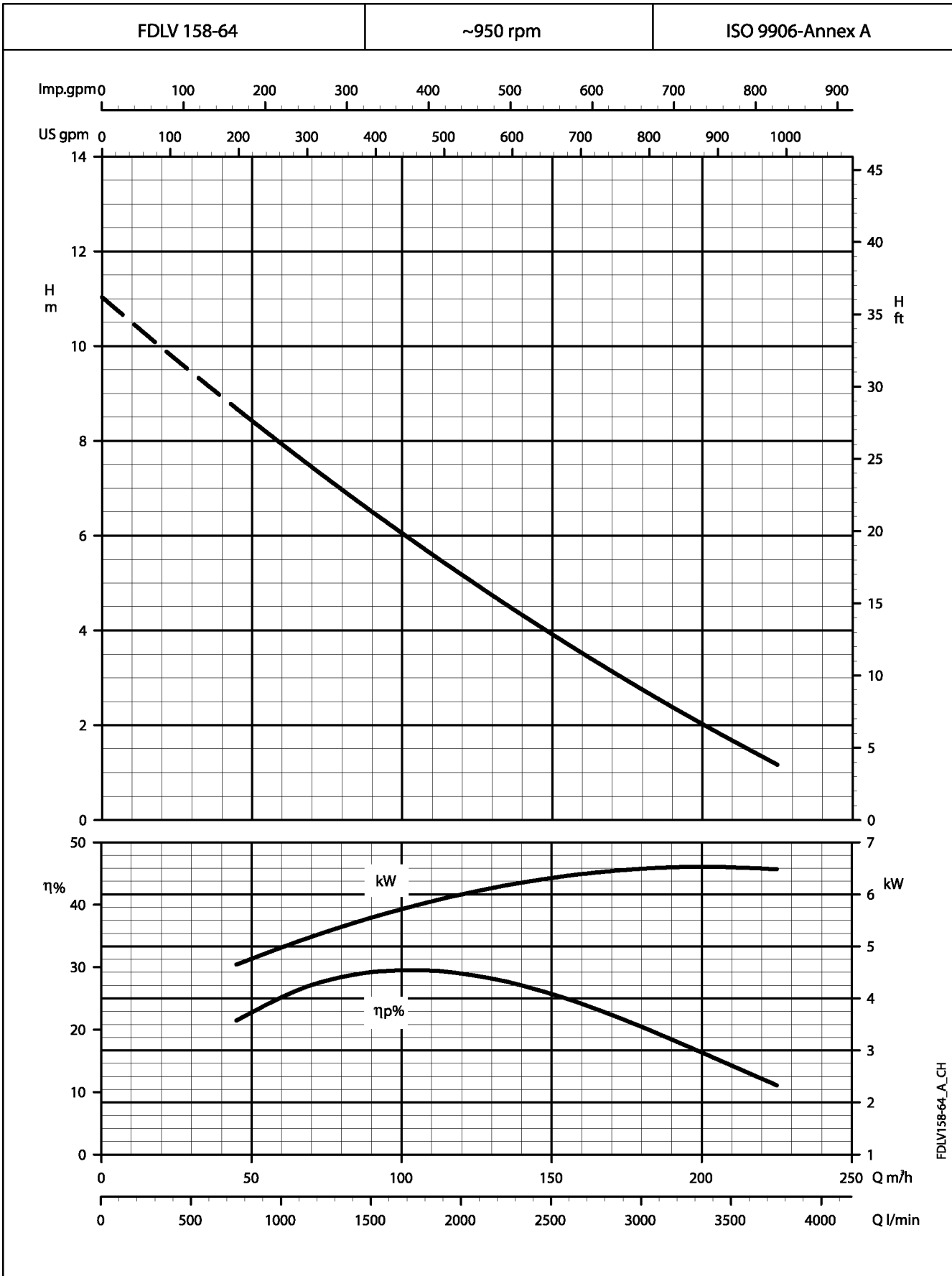

FDLV158-64_A_CH

These performances are valid for liquids with density $\rho = 1.0 \text{ kg/dm}^3$ and kinematic viscosity $\gamma = 1 \text{ mm}^2/\text{s}$.

**FDLV SERIES
OPERATING CHARACTERISTICS AT 950 rpm 50 Hz**

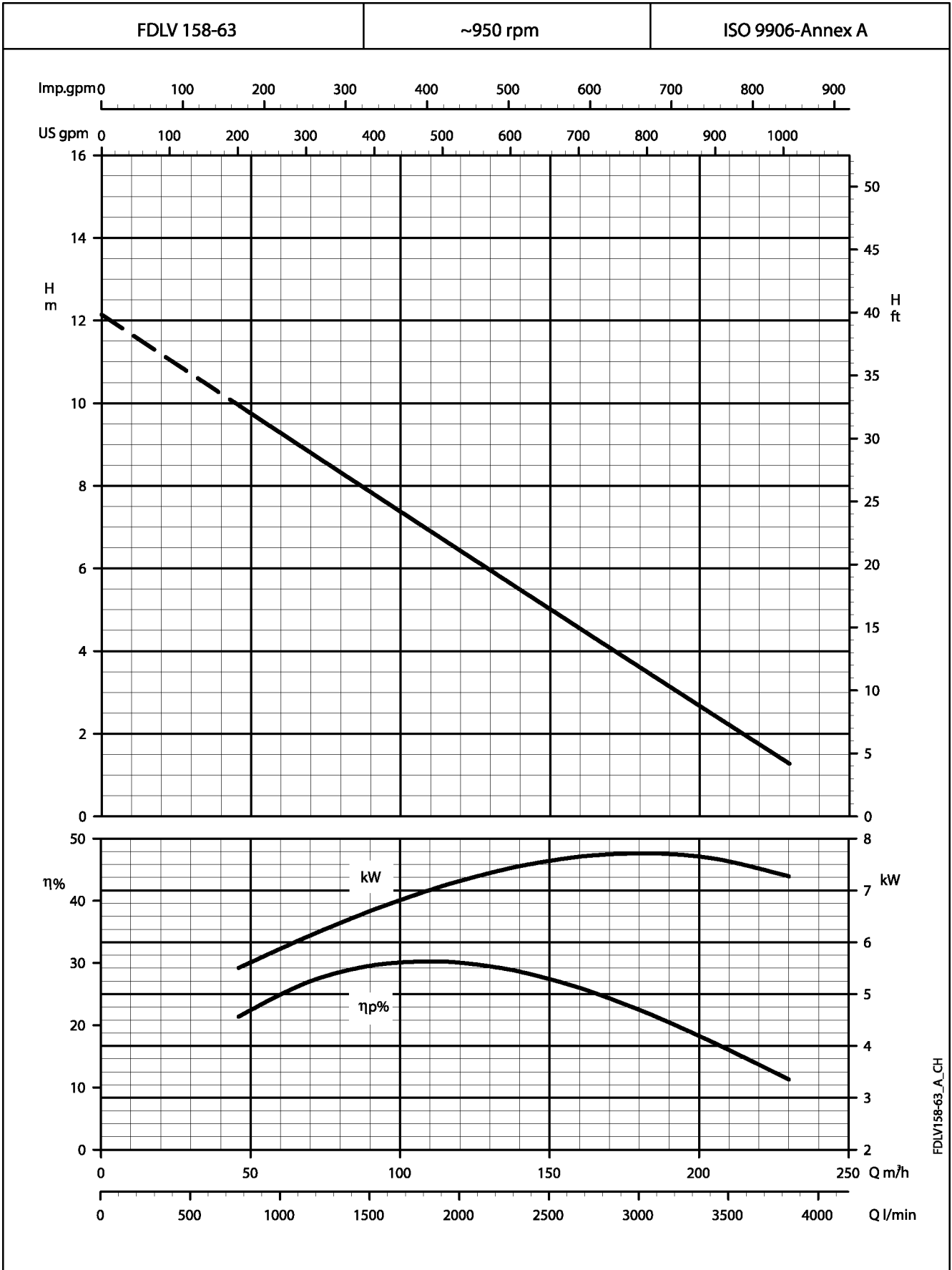

These performances are valid for liquids with density $\rho = 1.0 \text{ kg/dm}^3$ and kinematic viscosity $\gamma = 1 \text{ mm}^2/\text{s}$.

**FDLV SERIES
OPERATING CHARACTERISTICS AT 950 rpm 50 Hz**

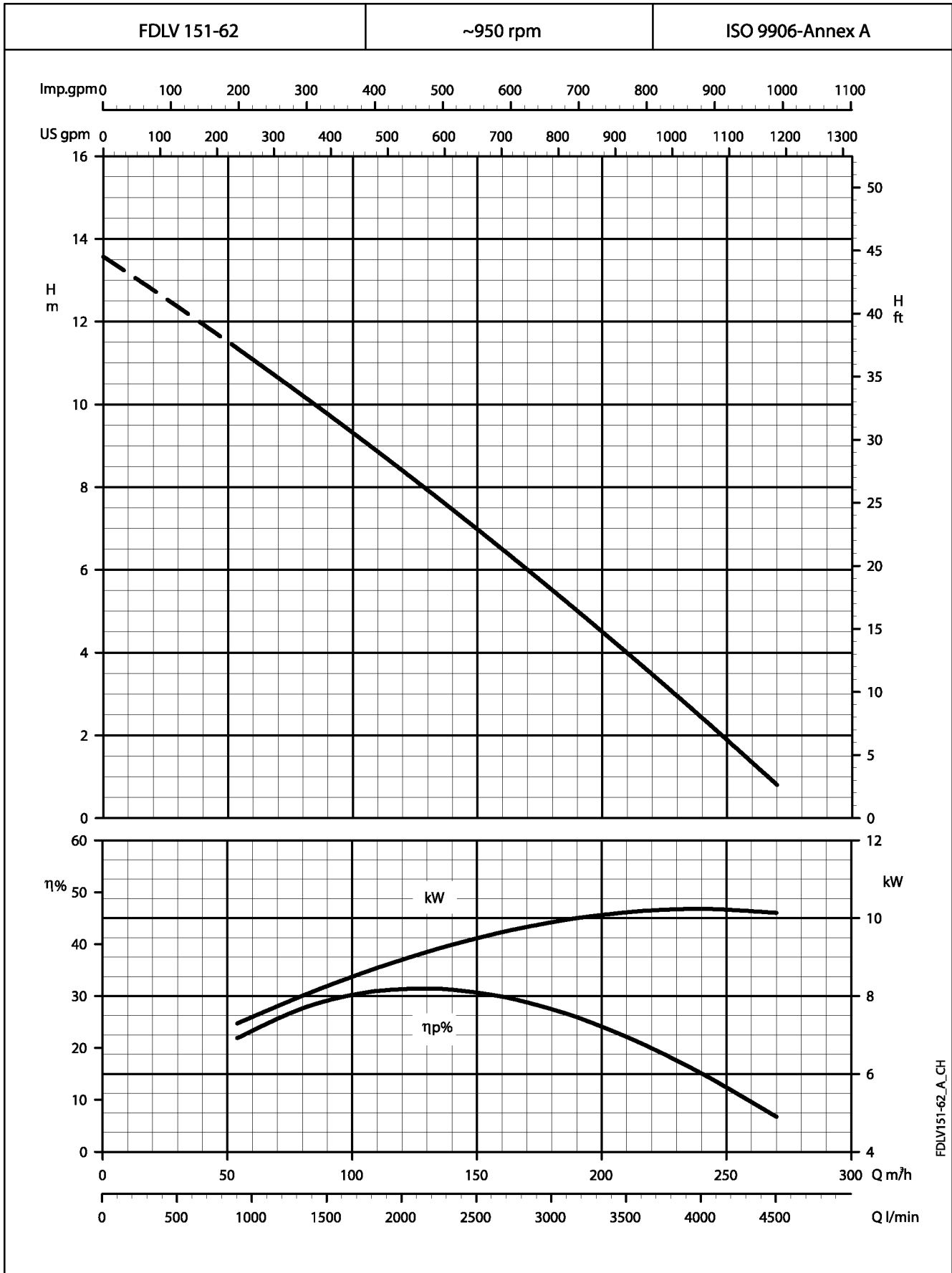

These performances are valid for liquids with density $\rho = 1.0 \text{ kg/dm}^3$ and kinematic viscosity $\nu = 1 \text{ mm}^2/\text{s}$.

**FDLV SERIES
OPERATING CHARACTERISTICS AT 950 rpm 50 Hz**

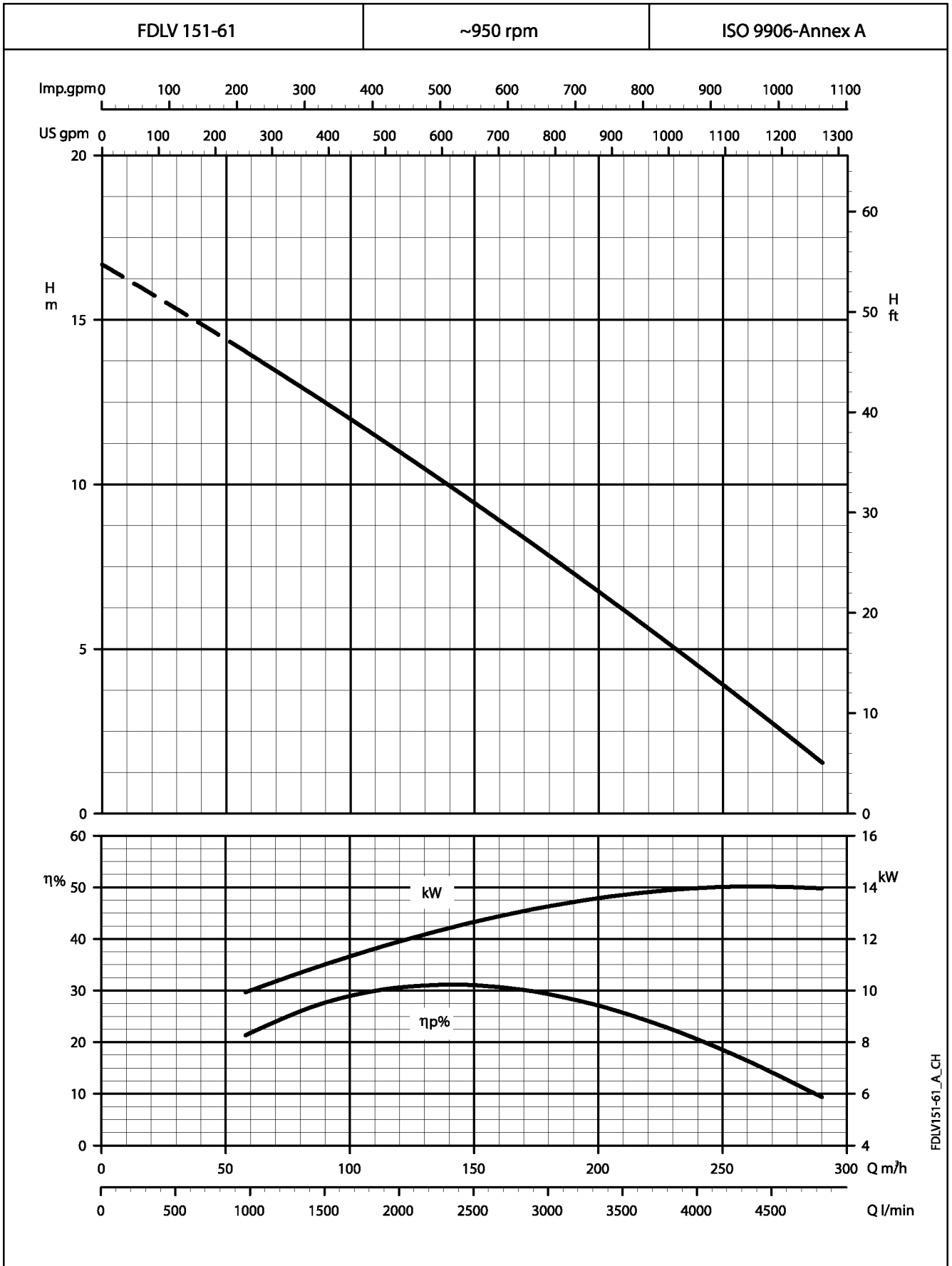

These performances are valid for liquids with density $\rho = 1.0 \text{ kg/dm}^3$ and kinematic viscosity $\gamma = 1 \text{ mm}^2/\text{s}$.

DIMENSIONS AND WEIGHTS, FDLV SERIES (DN65)

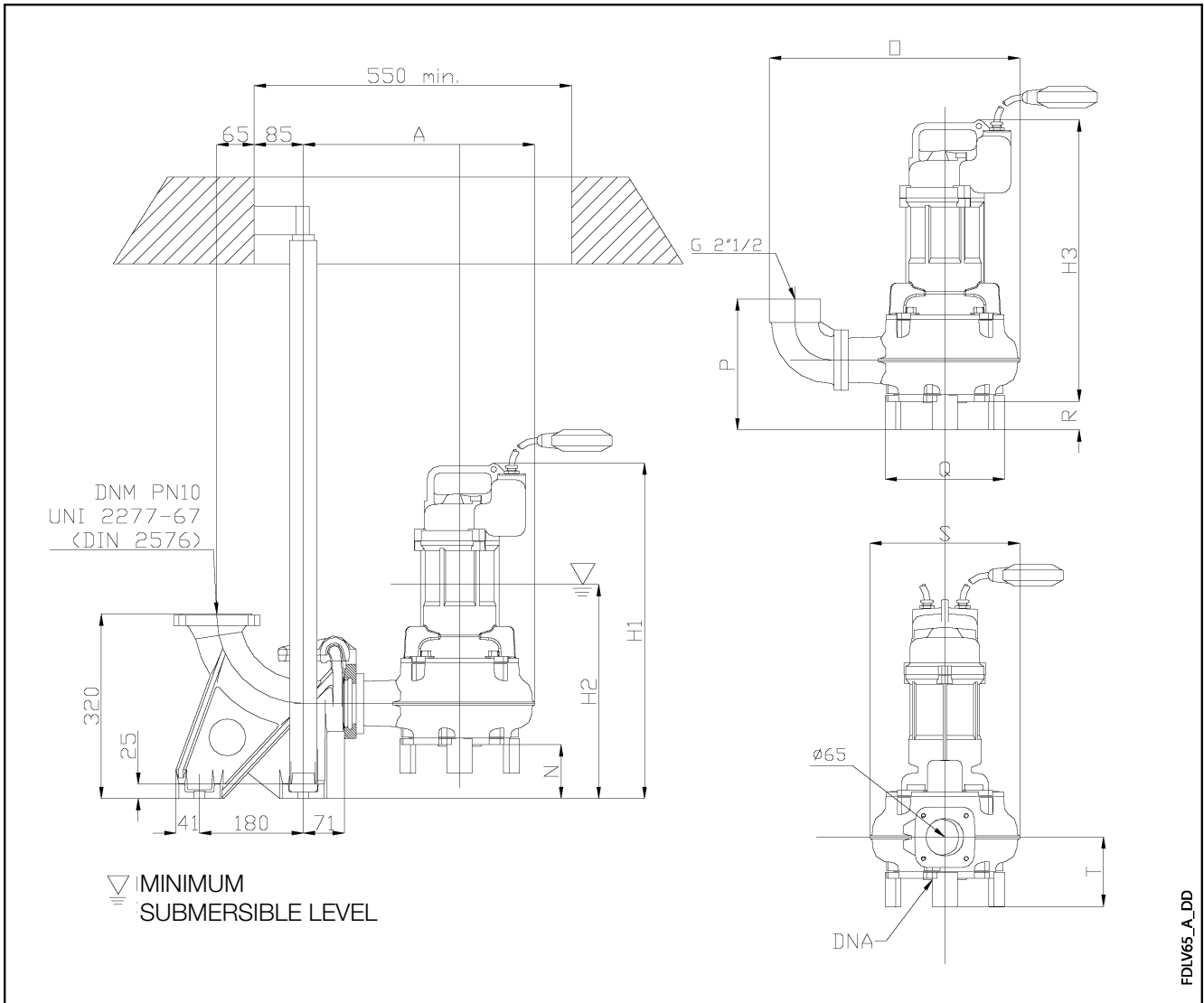

PUMP TYPE	DIMENSIONS (mm)											DNA	DNM	WEIGHT kg
	A	N	O	P	Q	R	S	T	H1	H2	H3			
FDLV 62-22	419	78	443	374	364	140	246	88	628	443	550	DN 80	DN 65	52
FDLV 62-21	419	78	443	374	364	140	246	88	628	443	550	DN 80	DN 65	52
FDLV 62-45	414	91	434	227	370	140	260	121	578	371	491	55	65	40
FDLV 62-44	414	91	434	227	370	140	260	121	578	371	491	55	65	40
FDLV 62-43	414	91	434	227	370	140	260	121	578	371	491	55	65	40
FDLV 61-42	444	68	465	385	370	140	292	98	579	387	512	DN 80	DN 65	58
FDLV 61-41	444	68	465	385	370	140	292	98	579	387	512	DN 80	DN 65	58

FDLV65_A_TD

DIMENSIONS AND WEIGHTS, FDLV SERIES (DN80)

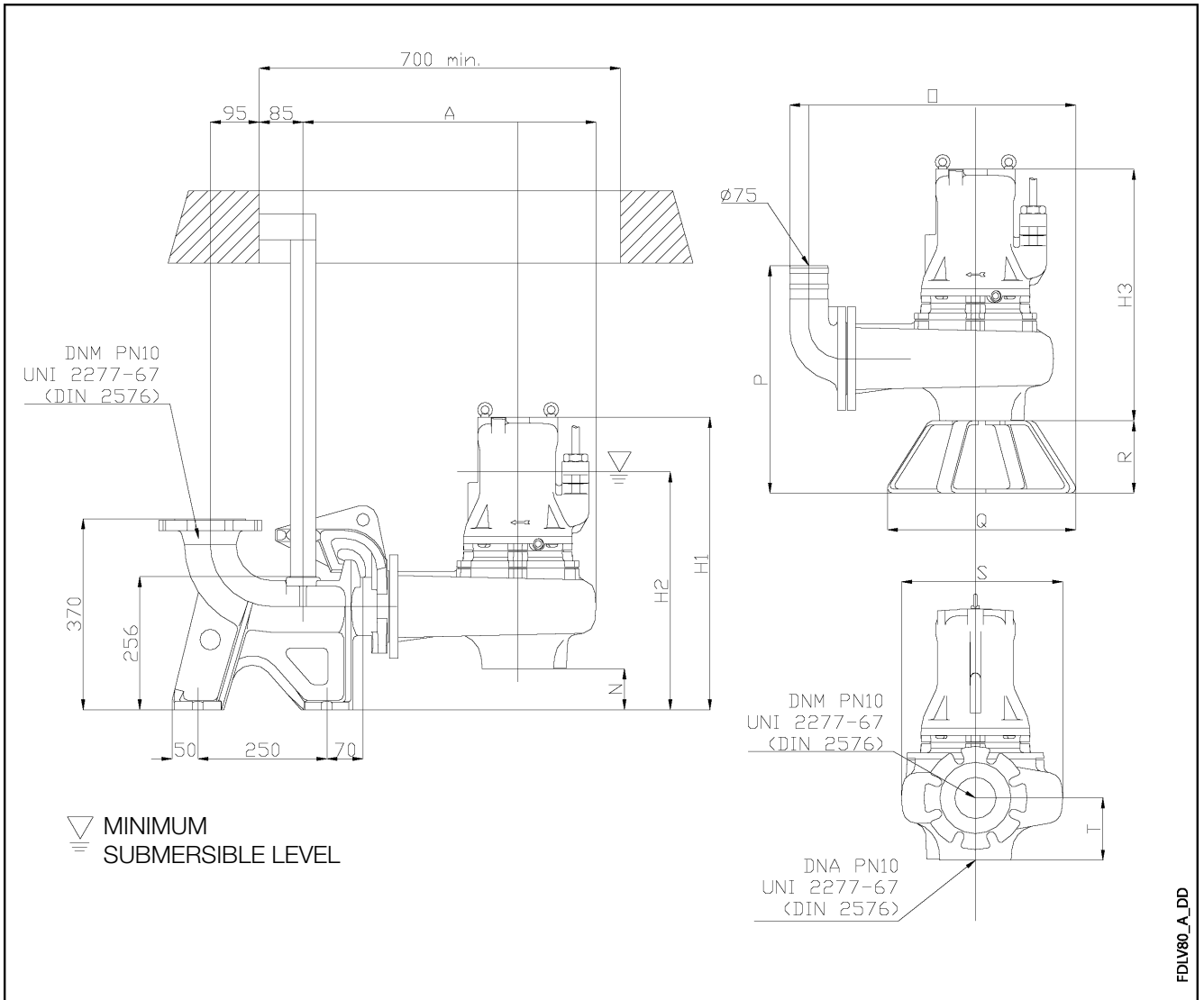

PUMP TYPE	DIMENSIONS (mm)											DNA	DNM	WEIGHT
	A	N	O	P	Q	R	S	T	H1	H2	H3			
FDLV 82-42N	568	80	512	441	370	140	312	121	567	451	487	DN 80	DN 80	64
FDLV 82-41N	568	80	512	441	370	140	312	121	567	451	487	DN 80	DN 80	64
FDLV 84-22	564	125	509	394	370	140	300	91	681	443	560	DN 80	DN 80	70
FDLV 85-21	564	125	509	394	370	140	300	91	681	443	560	DN 80	DN 80	70
FDLV 815-24	559	122	509	398	370	140	298	78	853	526	731	DN 80	DN 80	150
FDLV 815-23	559	122	509	398	370	140	298	78	853	526	731	DN 80	DN 80	150
FDLV 815-22	559	122	509	398	370	140	298	78	853	526	731	DN 80	DN 80	150
FDLV 815-21	559	122	509	398	370	140	298	78	853	526	731	DN 80	DN 80	150
FDLV 83-42N	568	80	512	441	370	140	312	121	626	481	546	DN 80	DN 80	75
FDLV 83-41N	568	80	512	441	370	140	312	121	626	481	546	DN 80	DN 80	75

FDLV80_A_TD

DIMENSIONS AND WEIGHTS, FDLV SERIES (DN100)

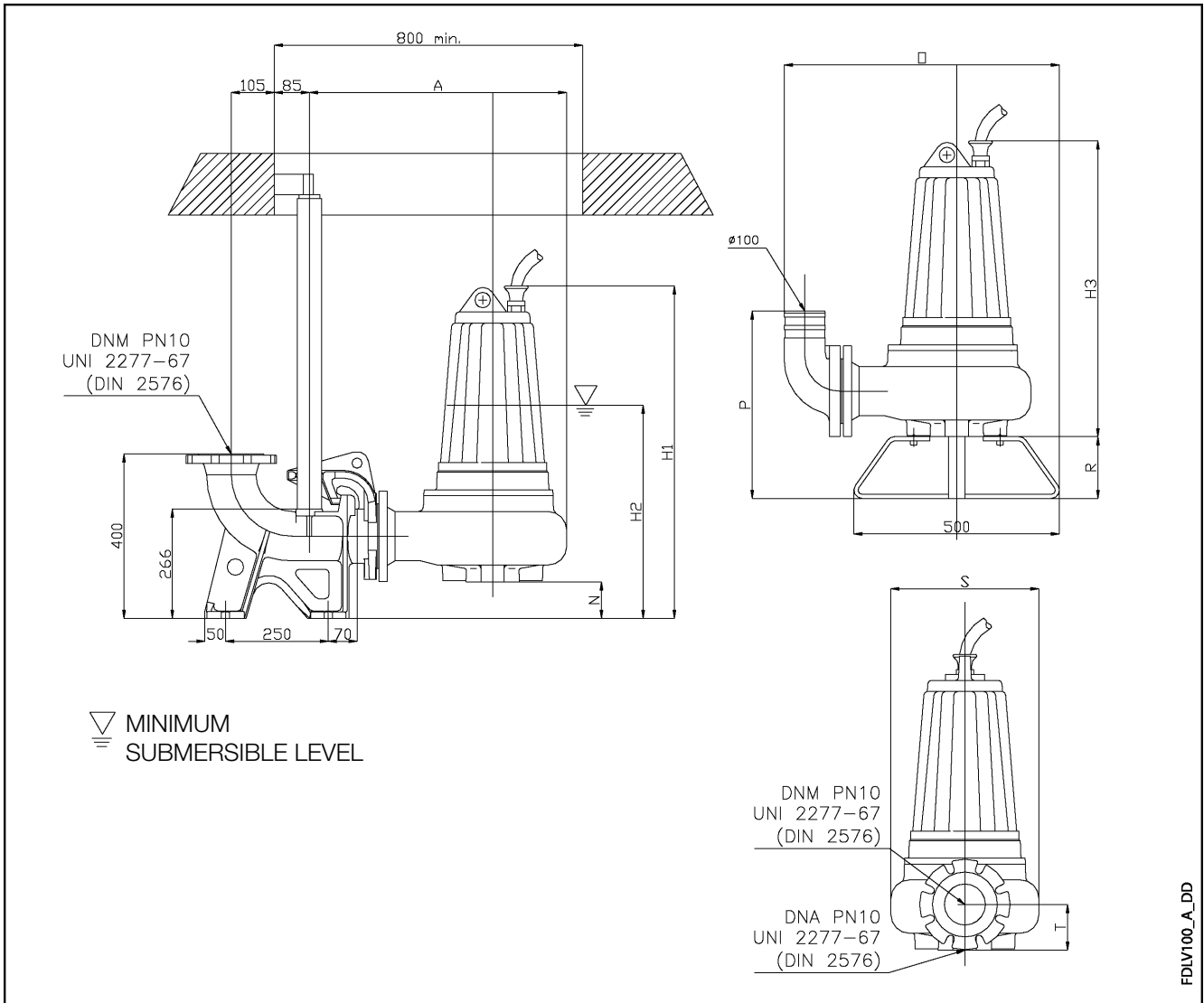

PUMP TYPE	DIMENSIONS (mm)										DNA	DNM	WEIGHT kg
	A	N	O	P	R	S	T	H1	H2	H3			
FDLV 104-41	626	90	670	491	150	360	110	731	492	641	DN125	DN 100	107
FDLV 106-42	626	90	670	491	150	360	110	810	519	720	DN125	DN 100	123
FDLV 106-41	626	90	670	491	150	360	110	810	519	720	DN125	DN 100	123

FDLV100_A_TD

DIMENSIONS AND WEIGHTS, FDLV SERIES (DN150)

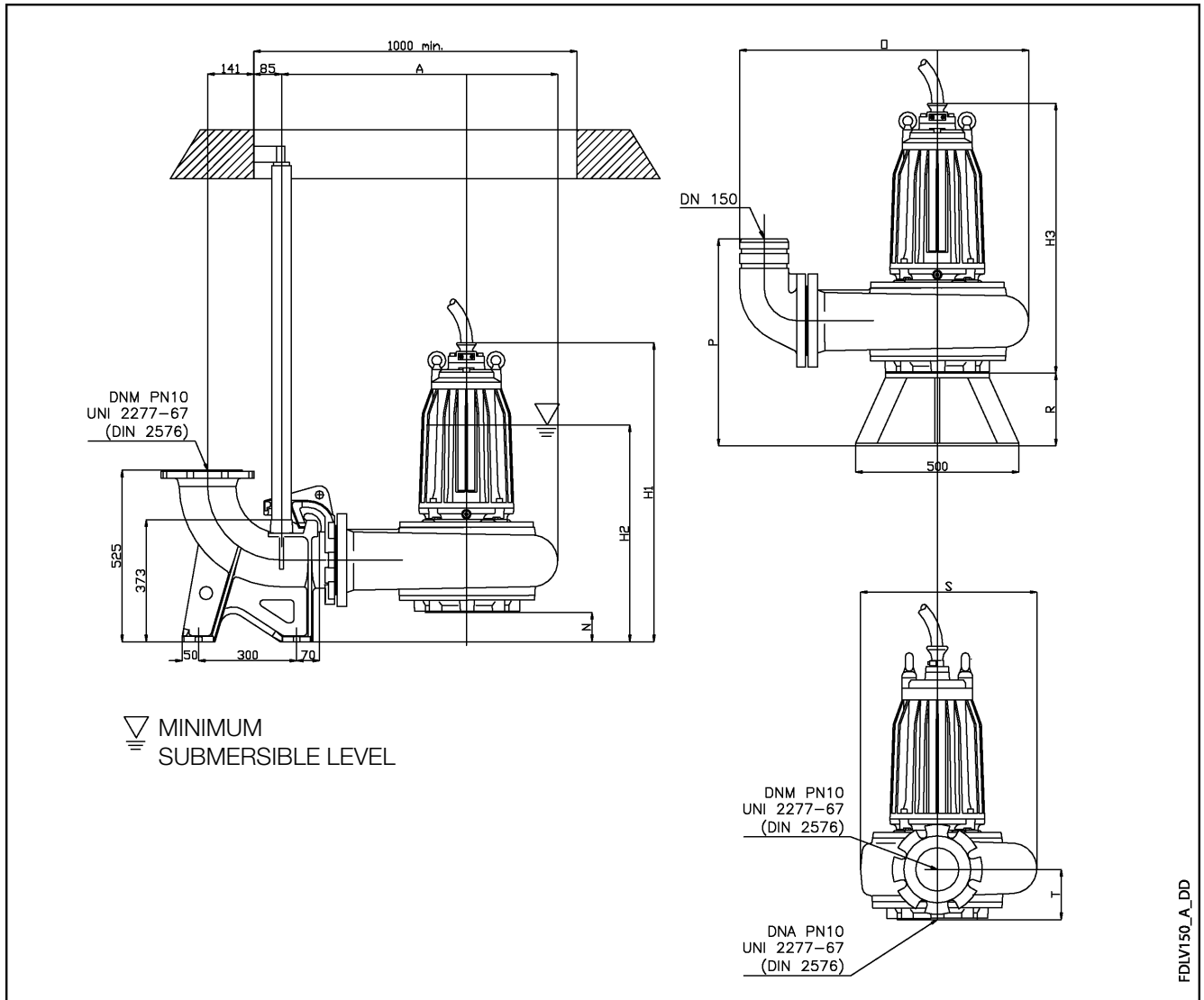

PUMP TYPE	DIMENSIONS (mm)										DNA	DNM	WEIGHT kg
	A	N	O	P	R	S	T	H1	H2	H3			
FDLV 158-64	880	125	919	597	222	528	142	987	658	862	DN150	DN 150	280
FDLV 158-63	880	125	919	597	222	528	142	987	658	862	DN150	DN 150	280
FDLV 151-62	880	125	919	597	222	528	142	1139	717	1014	DN150	DN 150	361
FDLV 151-61	880	125	919	597	222	528	142	1139	717	1014	DN150	DN 150	330
FDLV 152-44	880	125	919	597	222	528	142	1139	717	1014	DN150	DN 150	330
FDLV 152-43	880	125	919	597	222	528	142	1139	717	1014	DN150	DN 150	330
FDLV 152-42	880	125	919	597	222	528	142	1139	717	1014	DN150	DN 150	330
FDLV 153-41	880	125	919	597	222	528	142	1139	717	1014	DN150	DN 150	361

FDLV150_A_TD

**SEZIONE POMPA
SERIE FDLV**

FDLV

Shafts: in contact with liquid made of AISI 420B stainless steel.

Motor: three-phase asynchronous 2-4-6 poles, insulation class F (155°C). Dry, cooled by the surrounding liquid.

Oil chamber: the oil lubricates and cools the seals and emulsifies any water leaks. The pump is equipped with two mechanical seals for perfect insulation between the electric motor and the pumped liquid.
Upper seal: ceramic/graphite
Lower seal: silicon carbide/silicon carbide.

The radial bearings are sized for minimum 10,000 hours of operation.

Passes large diameter solids.

Impeller

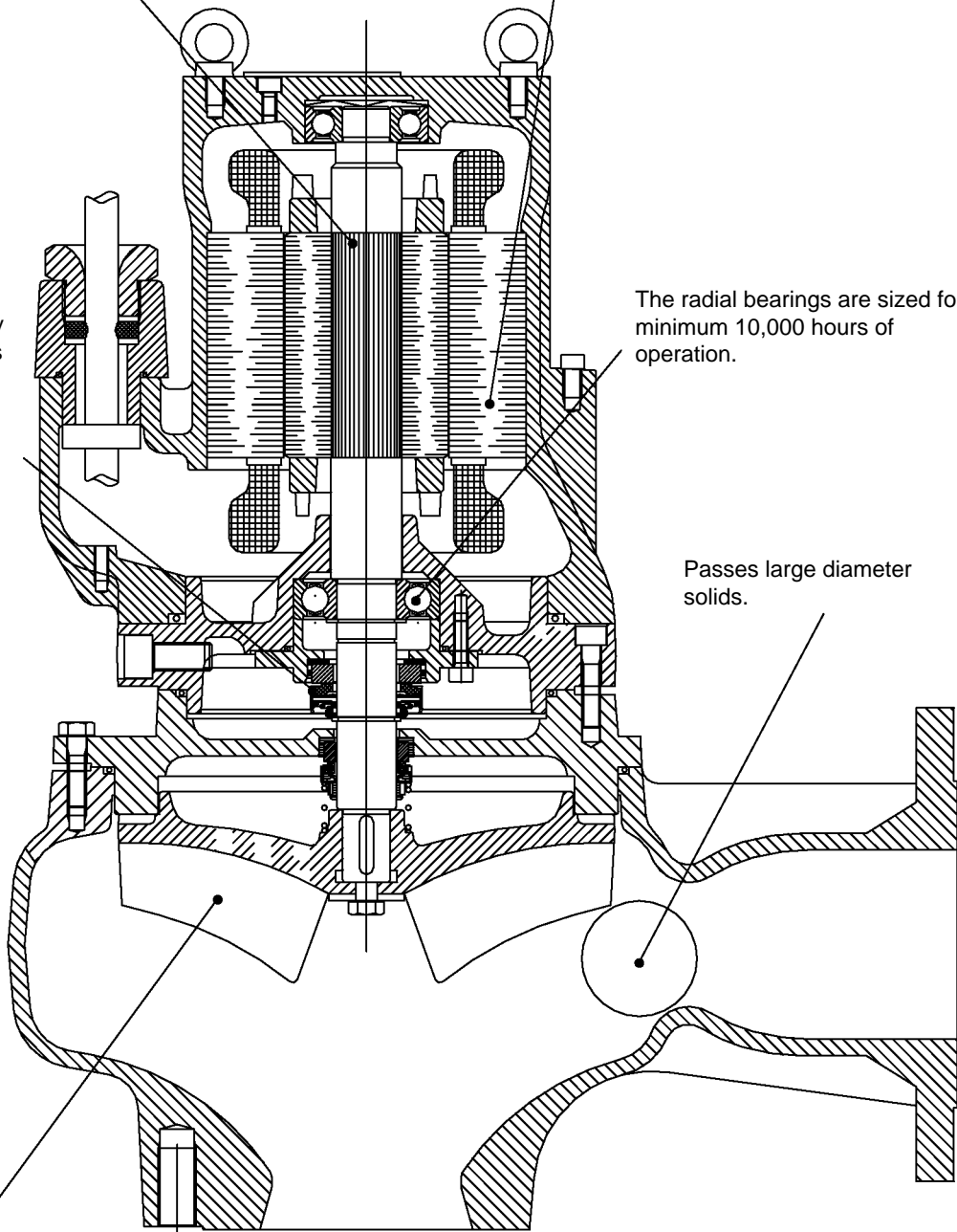

Submersible Electric Pumps

FDLT Series



MARKET SECTORS

DOMESTIC, AGRICULTURAL, INDUSTRIAL, MUNICIPAL, MINING INDUSTRY.

APPLICATIONS

- Handling of sewage, liquids, wastewater and industrial sludge, draining of flooded excavations and marshy ground.

SPECIFICATIONS

- **Delivery:** up to 15 m³/h.
- **Head:** up to 47 m.
- Maximum liquid **temperature:** 25-40°C (see hydraulic performance table).
- Maximum immersion depth: 20 m.
- **Passes solids** 6 to 7 mm in diameter.
- Motor with IP 68 protection and class F insulation (155°C).
 - Power supply: single-phase and three-phase, 50 Hz.
- **Motor power:** up to 5 kW.
 - Maximum number of starts per hour: approx. 20 (possibly more, depending on the application).

CONSTRUCTION CHARACTERISTICS

- Sturdy cast iron construction.
- Open **impeller** with grinder assembly.
- Double seal: Silicon Carbide / Silicon Carbide inner seal, Ceramic / Carbon upper seal or Nitrile Rubber seal ring with interposed oil chamber.
- Adjustable volute bottom cover to compensate for impeller wear and ensure stable long-lasting hydraulic performances.
- Oversized motor bearings.
- 10-metre power supply cable with neoprene sheath (H07RN-F).
- Moisture sensor in oil chamber (see electric data table).
- Control panel included (single-phase models only).

OPTIONAL FEATURES

- Cathodic protection
- Cooling sleeve for dry installations

- Version without float.
- Flameproof construction (EEx).

ACCESSORIES / INSTALLATION

- Lowering system.
- 90° delivery union.
- Threaded flange for delivery port.
- Tripod stand.
- Non-return ball valves.
- Floats for solids-laden waters.
- Control **panels**.

IDENTIFICATION CODE

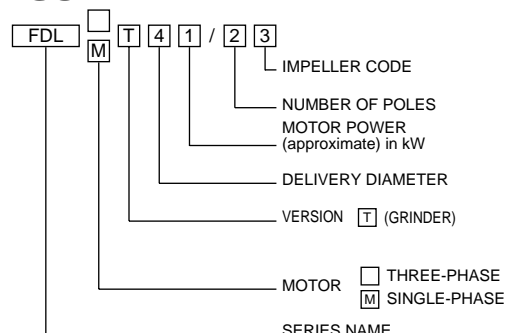

TABLE OF MATERIALS

PART	FDLT MATERIAL
Impeller, Pump body, Motor casing, Volute bottom, Upper cover	250 CAST IRON UNI-ISO 185
Shaft	STAINLESS STEEL (AISI 420B)
Grinder assembly	STAINLESS STEEL (AISI 440)
Bearings	LIFETIME LUBRICATED BALL TYPE
Upper seal	CERAMIC-GRAPHITE OR NITRILE RUBBER SEAL RING
Lower seal	SILICON CARBIDE / SILICON CARBIDE
Gaskets	NITRILE RUBBER
Bolts and screws	STAINLESS STEEL (AISI 304)

FDLT SERIES ELECTRICAL DATA (50 Hz)

PUMP TYPE	ABSORBED POWER*	rpm	ABSORBED CURRENT In(A)			STARTING CURRENT Isp (A)		ELECTRIC CABLE TYPE	STATOR THERMAL PROTECTION**	WATER SENSOR IN OIL CHAMBER**
			220-240 V	380-415 V		220-240 V	380-415 V			
			Δ	Y	Δ	A	A			
THREE-PHASE	kW									
FDLT 41-23	0,8	2850	4,0	2,3		18,3	10,6	4G1,5	NO	NO
FDLT 41-22	1,1	2850	4,3	2,5		19,9	11,5	4G1,5	NO	NO
FDLT 41-21	1,4	2850	5,0	2,9		21,1	12,2	4G1,5	NO	NO
FDLT 42-22	1,5	2850	5,2	3		21,8	12,6	4G1,5	NO	NO
FDLT 42-21	2	2850	6,6	3,8		27,7	16	4G1,5	NO	NO
FDLT 43-22	2,5	2850	7,8	4,5		45,2	26,1	4G2,5	NO	NO
FDLT 43-21	3,2	2850	9,5	5,5		55,2	31,9	4G2,5	NO	NO
FDLT 44-22	3,8	2850	12,1		7	78,7	45,5	12G1,5	YES	YES
FDLT 44-21	4,2	2850	13,0		7,5	84,4	48,8	12G1,5	YES	YES
FDLT 45-21	4,9	2850	14,9		8,6	96,7	55,9	12G1,5	YES	YES

PUMP TYPE	ABSORBED POWER*	rpm	ABSORBED CURRENT In(A) 220-240 V	CAPACITOR		STARTING CURRENT A	ELECTRIC CABLE TYPE	STATOR THERMAL PROTECTION	WATER SENSOR IN OIL CHAMBER
				μf	V				
				SINGLE-PHASE	kW				
FDLMT 41-23	0,8	2850	3,7	35	450	13	3G1,5	YES	NO
FDLMT 41-22	1,1	2850	4,5	35	450	15,8	3G1,5	YES	NO
FDLMT 41-21	1,4	2850	6,3	35	450	22,1	3G1,5	YES	NO
FDLMT 42-22	1,5	2850	7,1	35	450	24,8	3G1,5	YES	NO
FDLMT 42-21	2	2850	9,1	35	450	31,8	3G1,5	YES	NO

*Maximum values within the operating range

Fdlt-2p50_a_te

**Featured in the standard version

**FDLT SERIES
OPERATING CHARACTERISTICS AT 50 Hz**

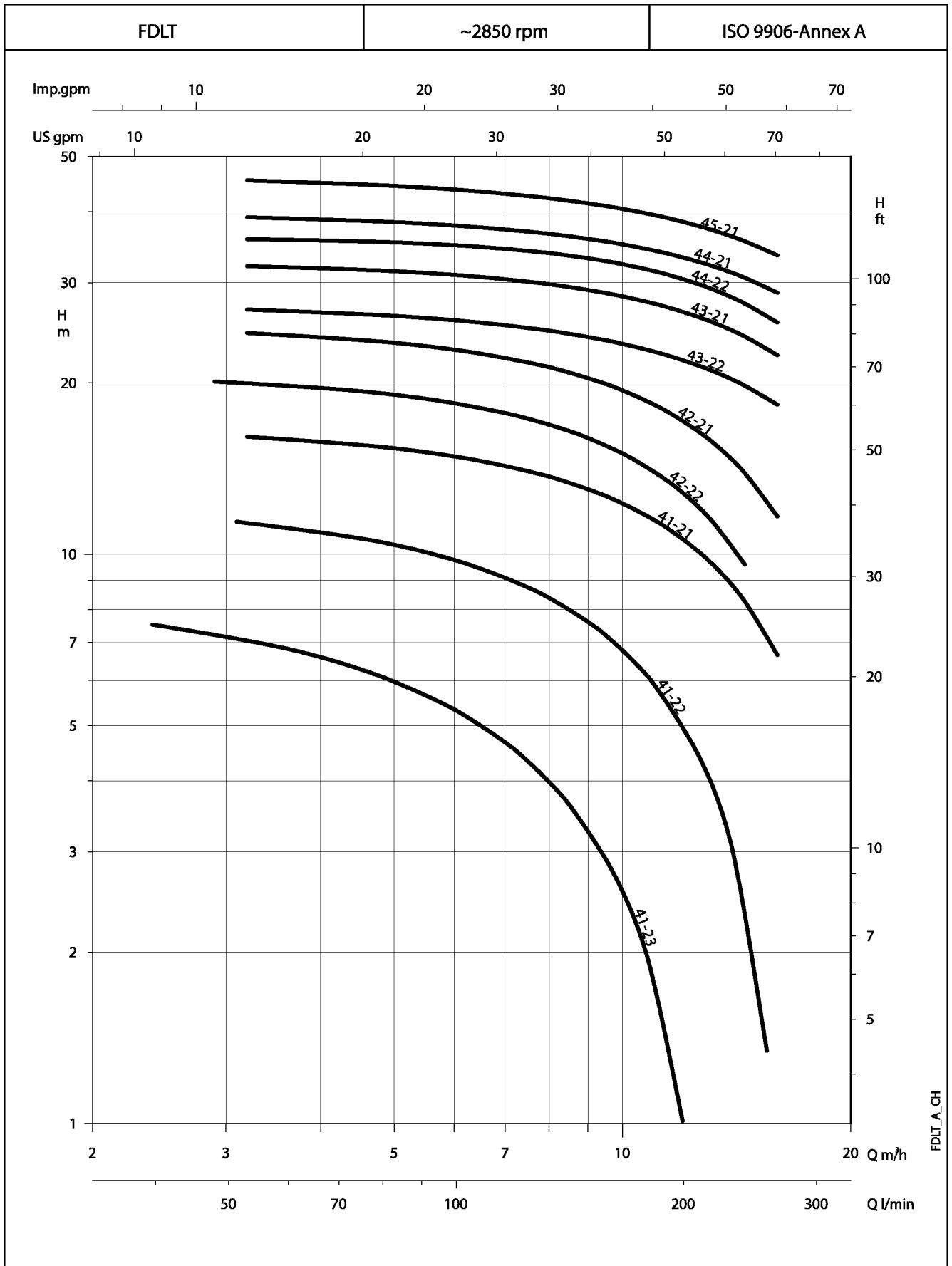

FDLT_A_CH

FDLT SERIES HYDRAULIC PERFORMANCE TABLE

PUMP TYPE	ABSORBED POWER kW	rpm	Q = DELIVERY									DNM	PASSES SOLIDS UP TO (mm)	MAX LIQUID TEMP. °C
			l/min 0	50	75	100	125	150	175	200	250			
			m ³ /h 0	3	4,5	6	7,5	9	10,5	12	15			
H = TOTAL HEAD METERS COLUMN OF WATER														
FDLMT 41-23	0,8	2850	8,6	7,0	6,1	5,2	4,2	3,2	2,0	0,9		40	6	40
FDLMT 41-22	1,1	2850	12,7	11,5	10,7	9,8	8,8	7,6	6,4	5,0	1,9	40	6	40
FDLMT 41-21	1,4	2850	16,9	16,2	15,6	14,9	14,0	13,0	11,9	10,7	7,7	40	6	40
FDLMT 42-22	1,5	2850	20,9	20,1	19,3	18,4	17,3	16,0	14,5	12,8		40	6	40
FDLMT 42-21	2,0	2850	25,5	24,6	23,8	22,9	21,7	20,4	18,9	17,2	13,2	40	6	40
FDLT 41-23	0,8	2850	8,8	7,2	6,3	5,3	4,3	3,3	2,2	1,0		40	6	40
FDLT 41-22	1,1	2850	12,7	11,5	10,7	9,8	8,8	7,6	6,4	5,0	1,9	40	6	40
FDLT 41-21	1,4	2850	16,9	16,2	15,6	14,9	14,0	13,0	11,9	10,7	7,7	40	6	40
FDLT 42-22	1,5	2850	20,9	20,1	19,3	18,4	17,3	16,0	14,5	12,8		40	6	40
FDLT 42-21	2,0	2850	25,5	24,6	23,8	22,9	21,7	20,4	18,9	17,2	13,2	40	6	40
FDLT 43-22	2,5	2850	27,7	27,0	26,4	25,8	25,0	24,1	23,1	21,9	19,3	40	7	40
FDLT 43-21	3,2	2850	32,7	32,1	31,6	31,0	30,1	29,1	28,0	26,7	23,6	40	7	40
FDLT 44-22	3,8	2850	35,8	35,8	35,5	34,9	34,1	33,1	31,9	30,5	26,9	40	7	40
FDLT 44-21	4,2	2850	39,9	39,2	38,6	37,8	36,9	35,8	34,6	33,2	30,0	40	7	40
FDLT 45-21	4,9	2850	46,6	45,5	44,7	43,7	42,6	41,4	40,0	38,4	34,8	40	7	40

PERFORMANCES MEASURED WITH PURE WATER AT 20 °C

FDLT_A_TH

**FDLMT SERIES
OPERATING CHARACTERISTICS AT 2850 rpm 50 Hz**

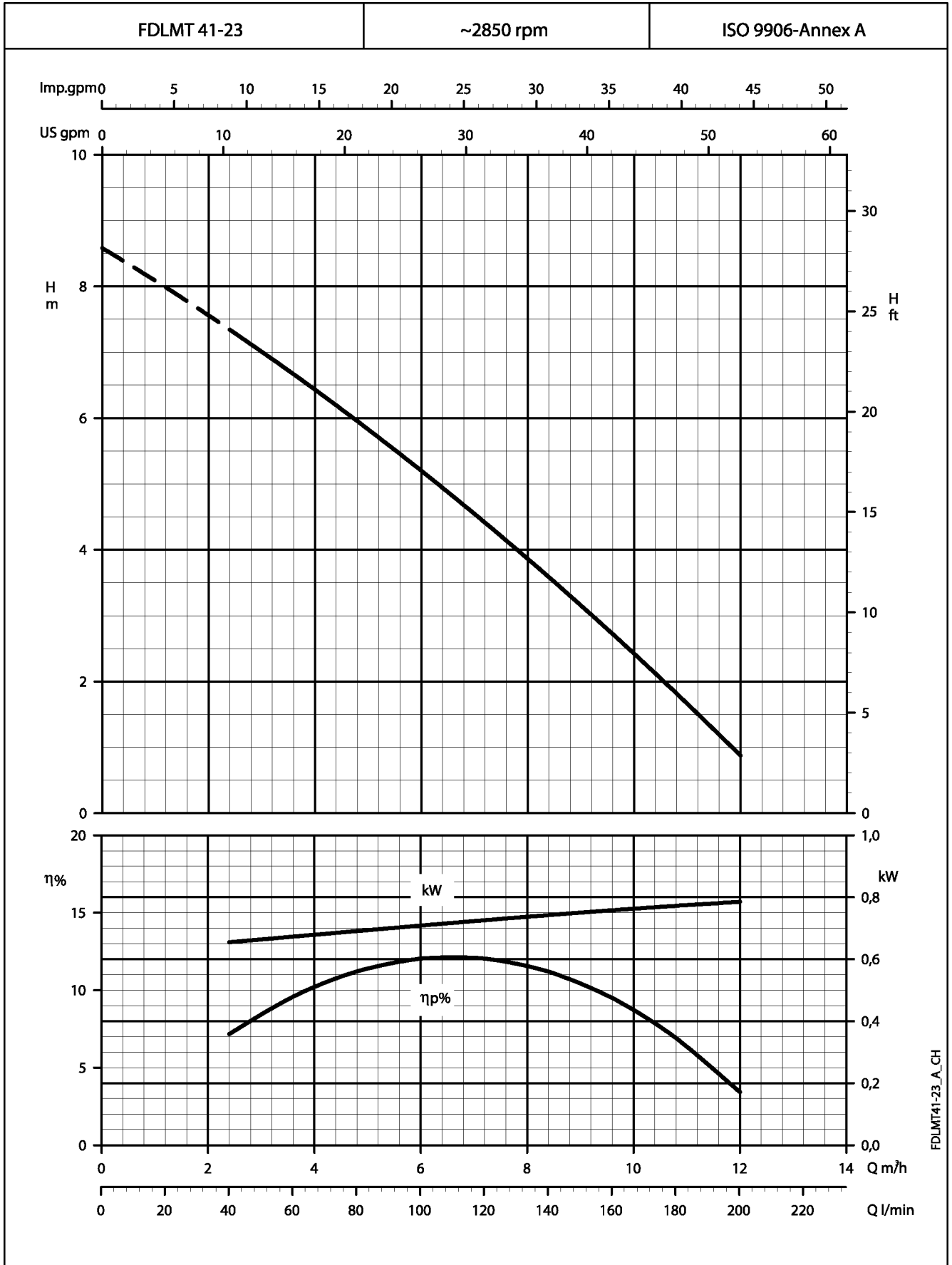

These performances are valid for liquids with density $\rho = 1.0 \text{ kg/dm}^3$ and kinematic viscosity $\gamma = 1 \text{ mm}^2/\text{s}$.

**FDLMT SERIES
OPERATING CHARACTERISTICS AT 2850 rpm 50 Hz**

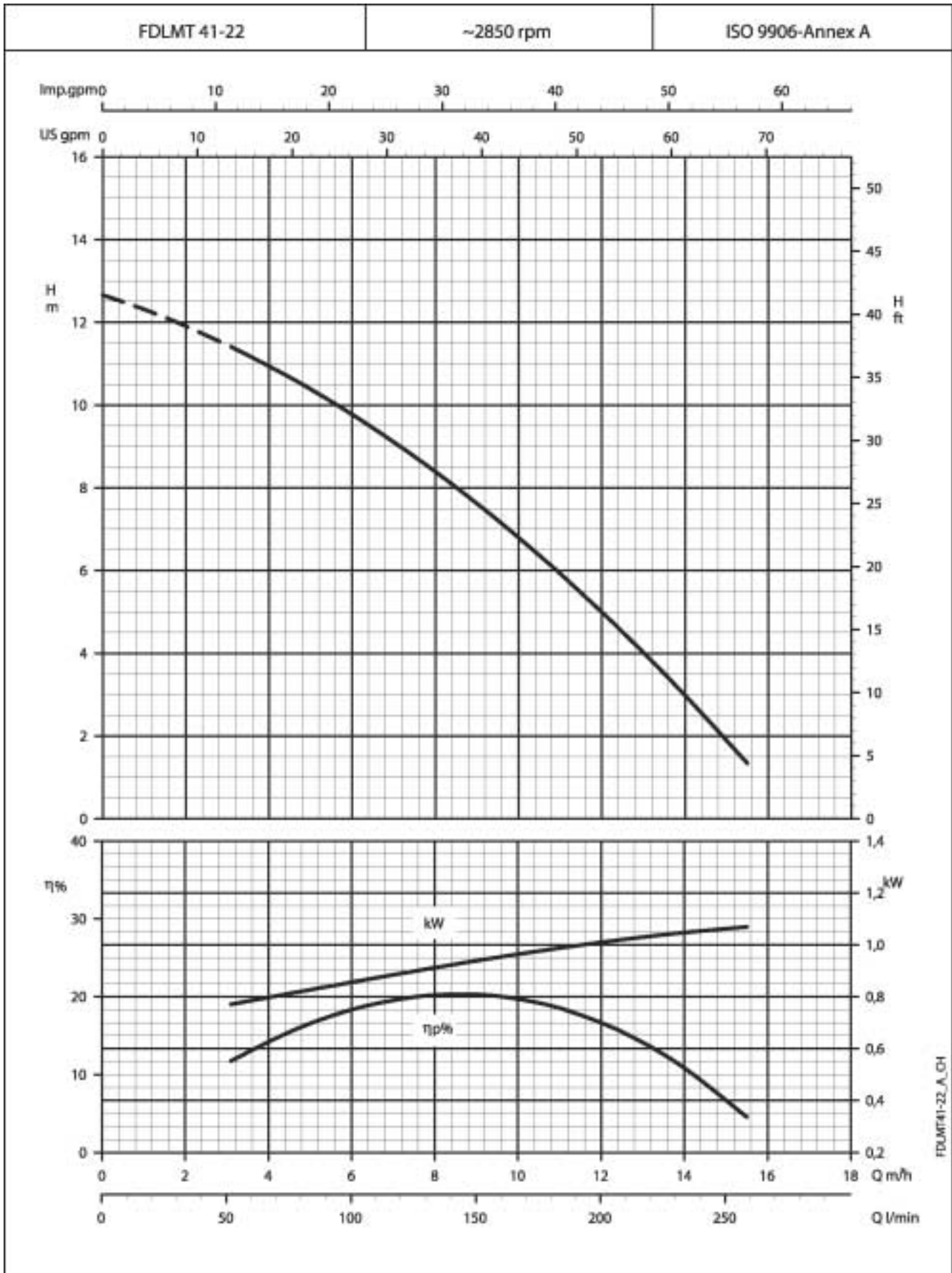

These performances are valid for liquids with density $\rho = 1.0 \text{ kg/dm}^3$ and kinematic viscosity $\nu = 1 \text{ mm}^2/\text{s}$.

**FDLMT SERIES
OPERATING CHARACTERISTICS AT 2850 rpm 50 Hz**

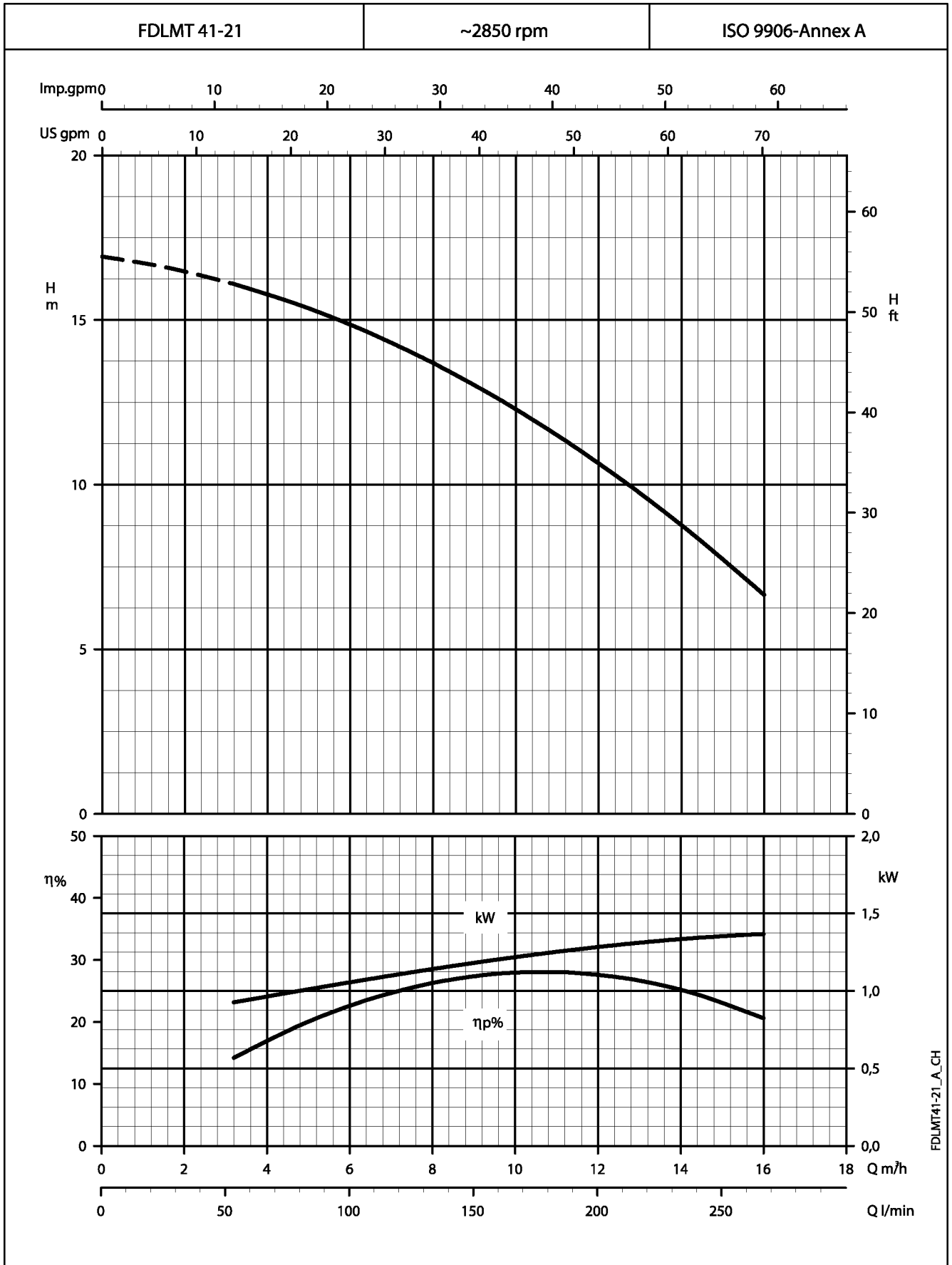

These performances are valid for liquids with density $\rho = 1.0 \text{ kg/dm}^3$ and kinematic viscosity $\gamma = 1 \text{ mm}^2/\text{s}$.

**FDLMT SERIES
OPERATING CHARACTERISTICS AT 2850 rpm 50 Hz**

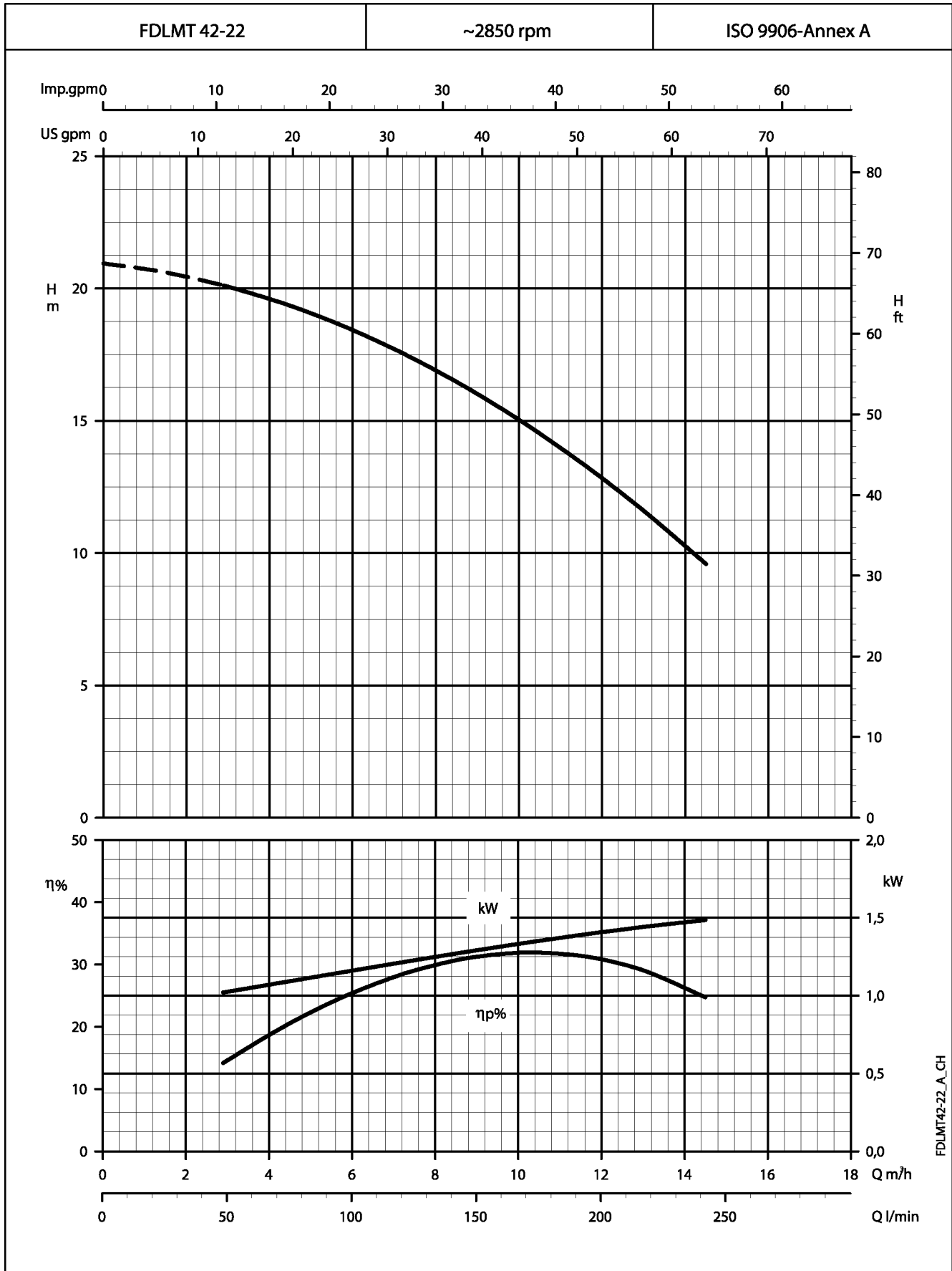

These performances are valid for liquids with density $\rho = 1.0 \text{ kg/dm}^3$ and kinematic viscosity $\gamma = 1 \text{ mm}^2/\text{s}$.

**FDLMT SERIES
OPERATING CHARACTERISTICS AT 2850 rpm 50 Hz**

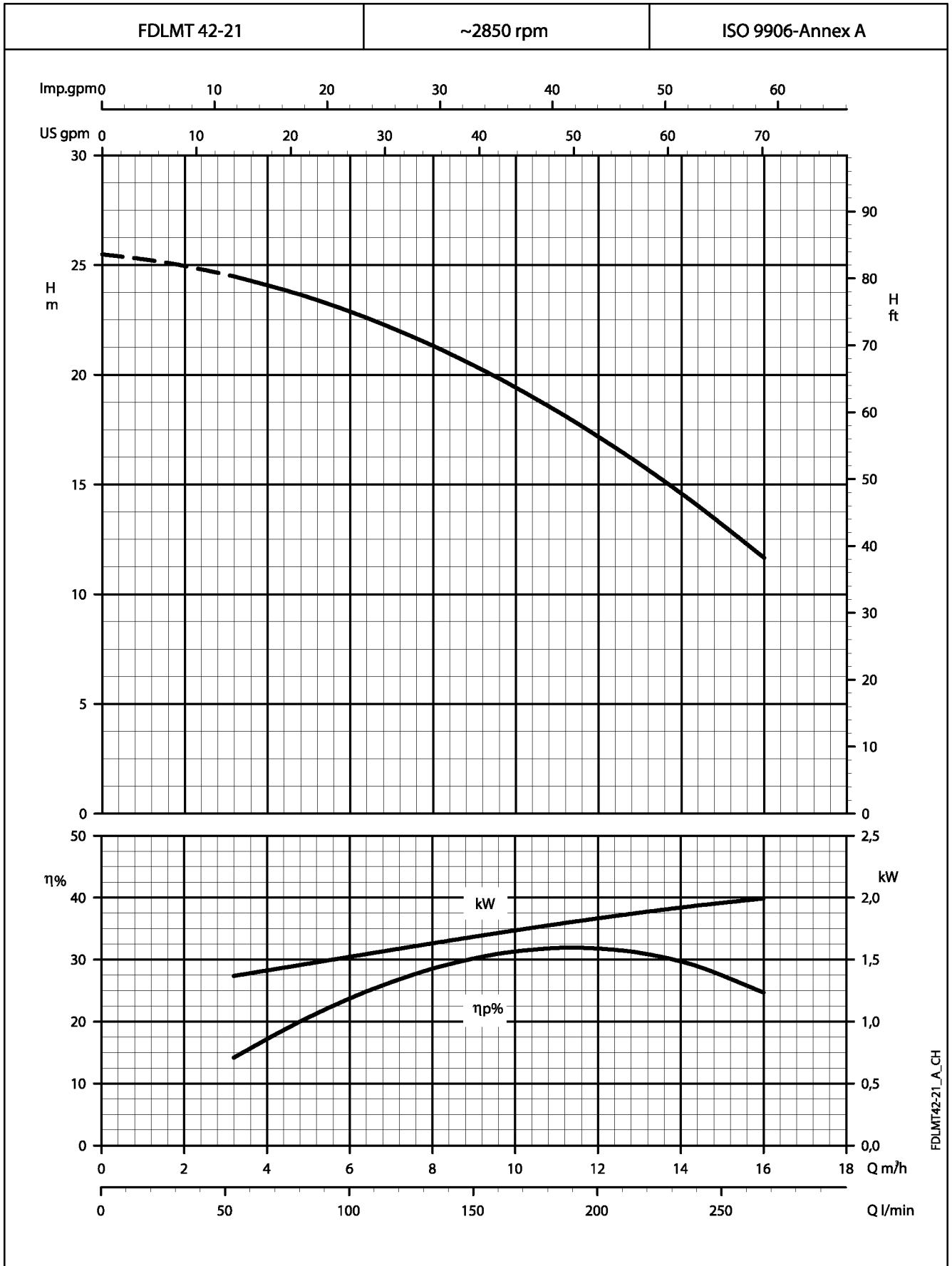

These performances are valid for liquids with density $\rho = 1.0 \text{ kg/dm}^3$ and kinematic viscosity $\gamma = 1 \text{ mm}^2/\text{s}$.

**FDLT SERIES
OPERATING CHARACTERISTICS AT 2850 rpm 50 Hz**

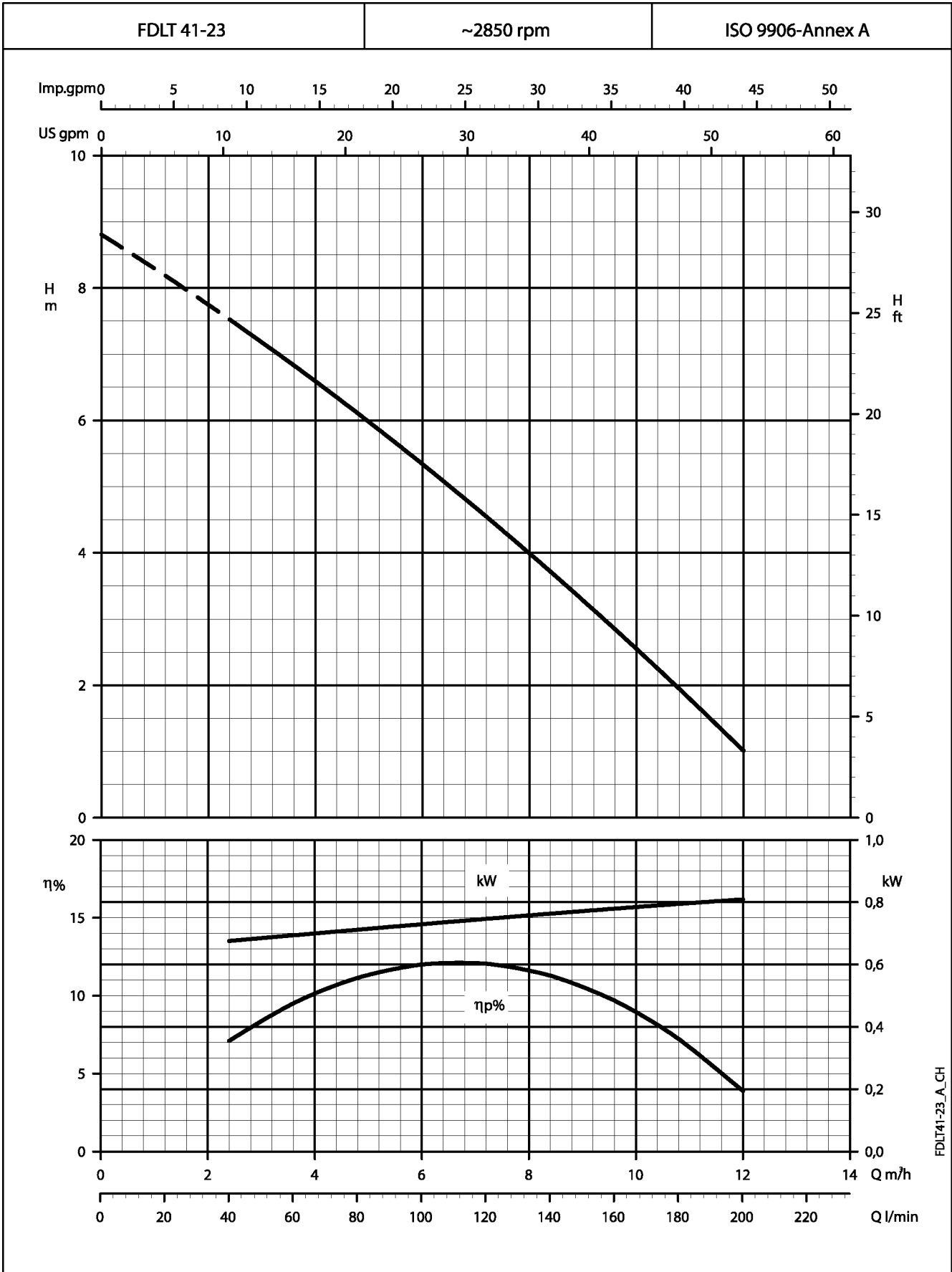

These performances are valid for liquids with density $\rho = 1.0 \text{ kg/dm}^3$ and kinematic viscosity $\nu = 1 \text{ mm}^2/\text{s}$.

**FDLT SERIES
OPERATING CHARACTERISTICS AT 2850 rpm 50 Hz**

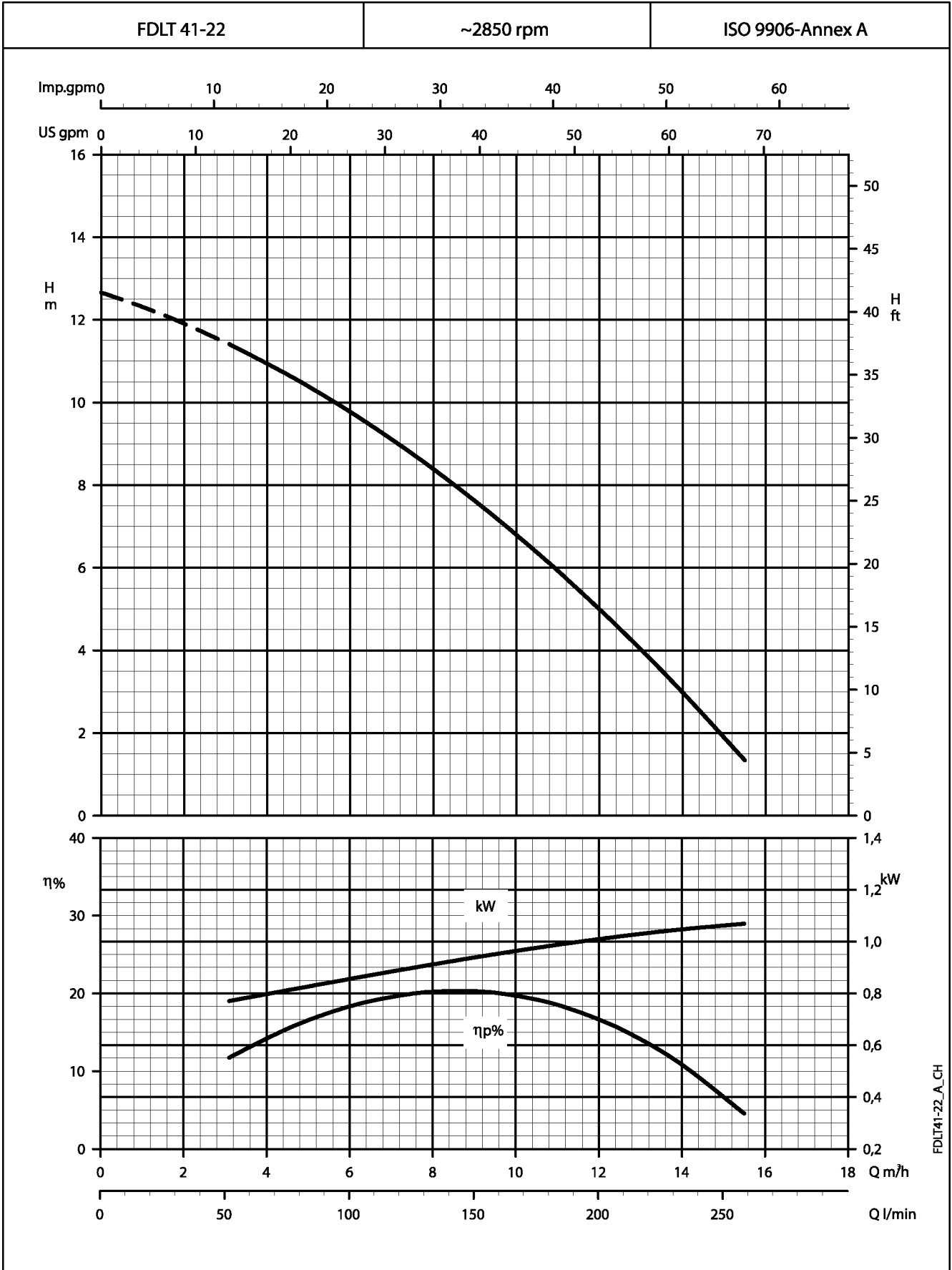

These performances are valid for liquids with density $\rho = 1.0 \text{ kg/dm}^3$ and kinematic viscosity $\gamma = 1 \text{ mm}^2/\text{s}$.

**FDLT SERIES
OPERATING CHARACTERISTICS AT 2850 rpm 50 Hz**

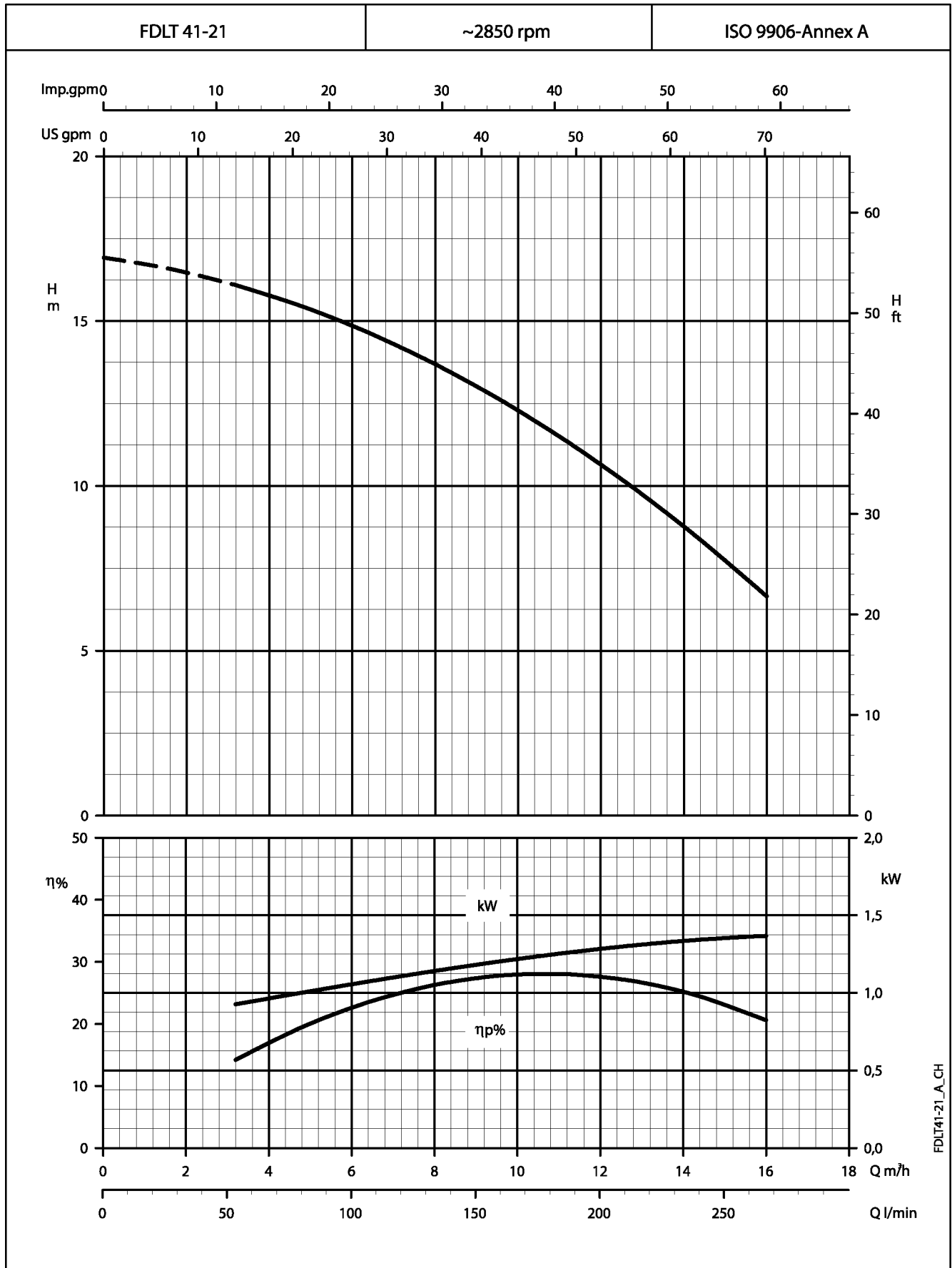

These performances are valid for liquids with density $\rho = 1.0 \text{ kg/dm}^3$ and kinematic viscosity $\nu = 1 \text{ mm}^2/\text{s}$.

**FDLT SERIES
OPERATING CHARACTERISTICS AT 2850 rpm 50 Hz**

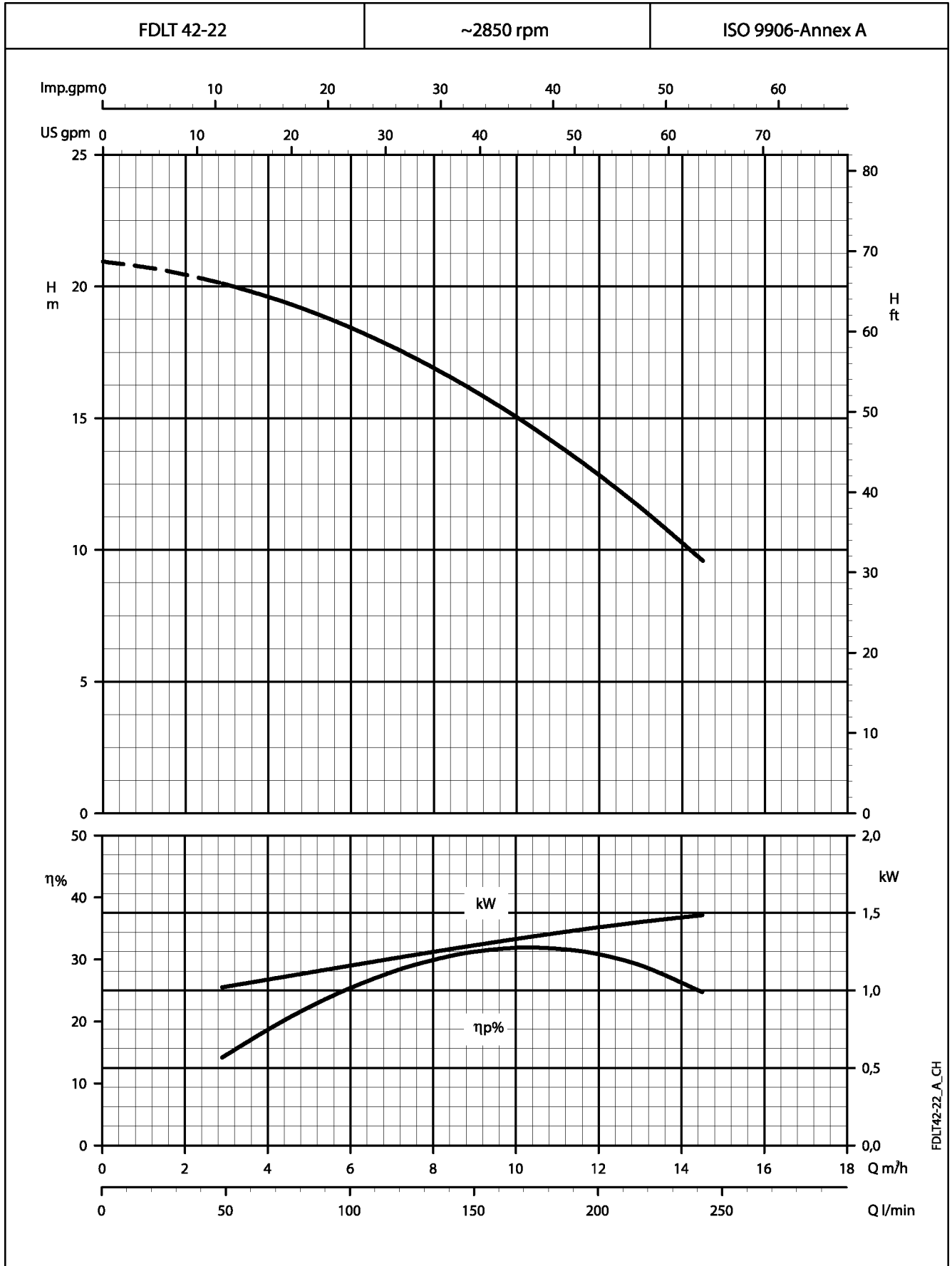

These performances are valid for liquids with density $\rho = 1.0 \text{ kg/dm}^3$ and kinematic viscosity $\gamma = 1 \text{ mm}^2/\text{s}$.

**FDLT SERIES
OPERATING CHARACTERISTICS AT 2850 rpm 50 Hz**

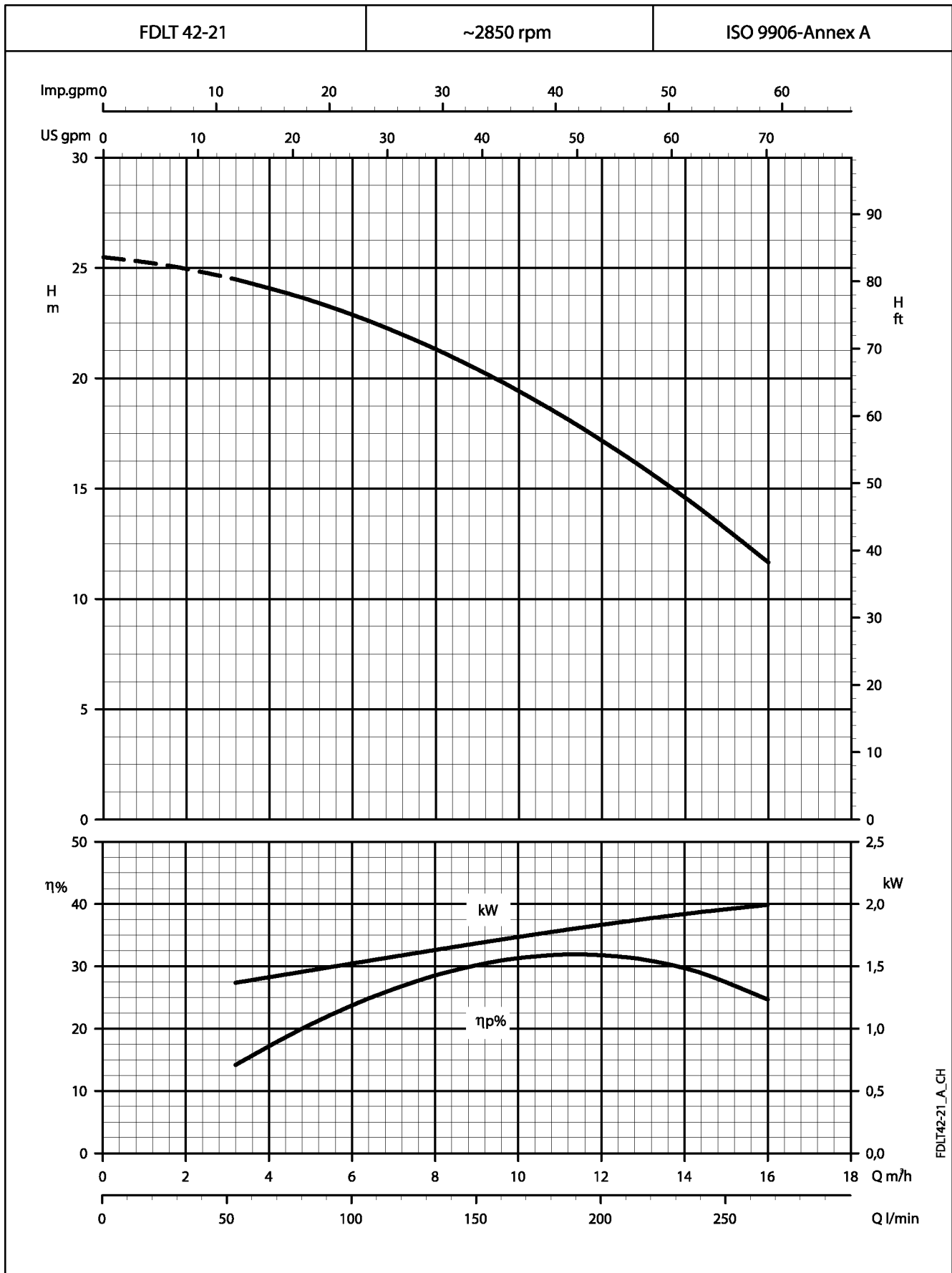

These performances are valid for liquids with density $\rho = 1.0 \text{ kg/dm}^3$ and kinematic viscosity $\gamma = 1 \text{ mm}^2/\text{s}$.

**FDLT SERIES
OPERATING CHARACTERISTICS AT 2850 rpm 50 Hz**

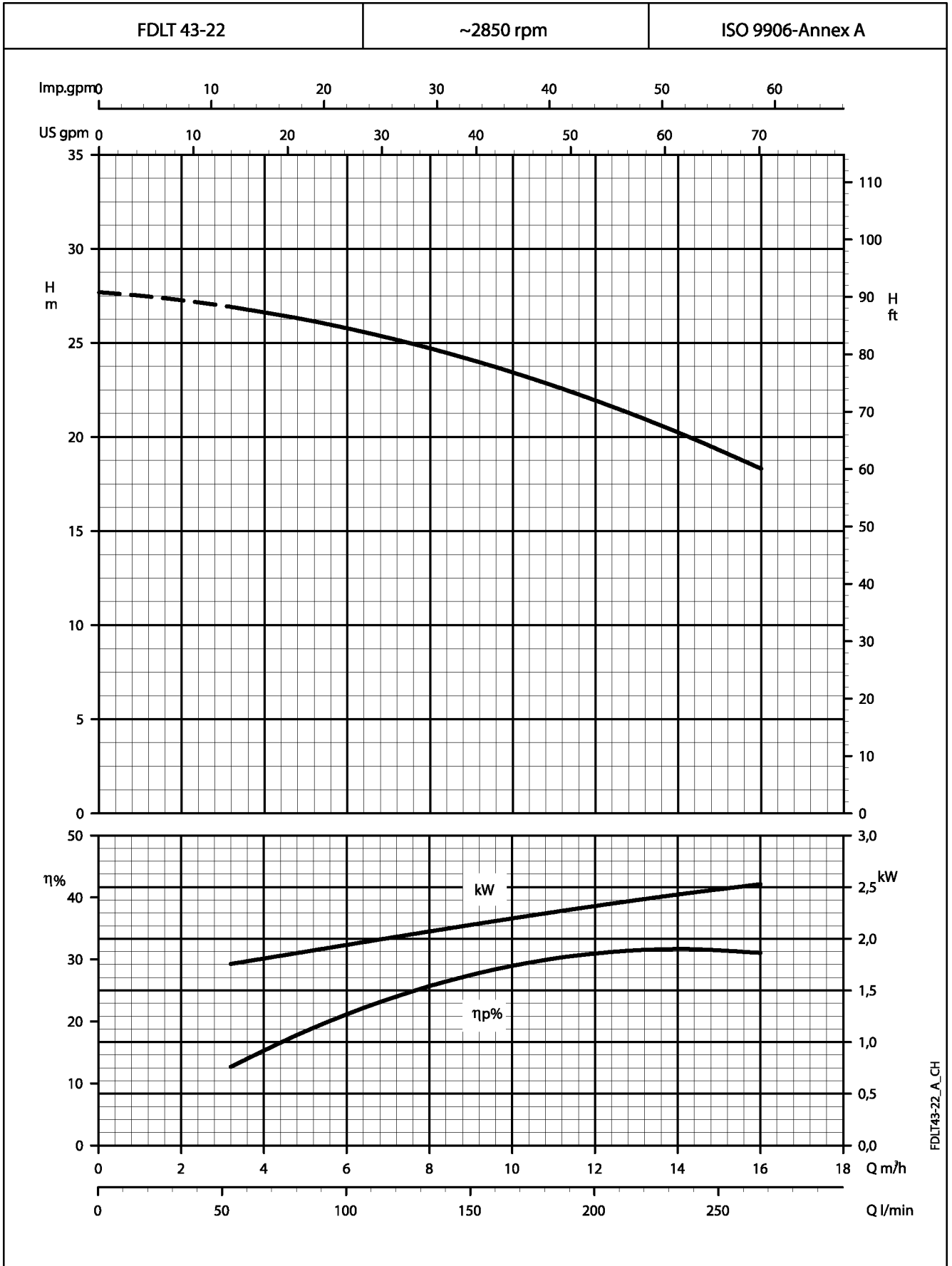

These performances are valid for liquids with density $\rho = 1.0 \text{ kg/dm}^3$ and kinematic viscosity $\gamma = 1 \text{ mm}^2/\text{s}$.

**FDLT SERIES
OPERATING CHARACTERISTICS AT 2850 rpm 50 Hz**

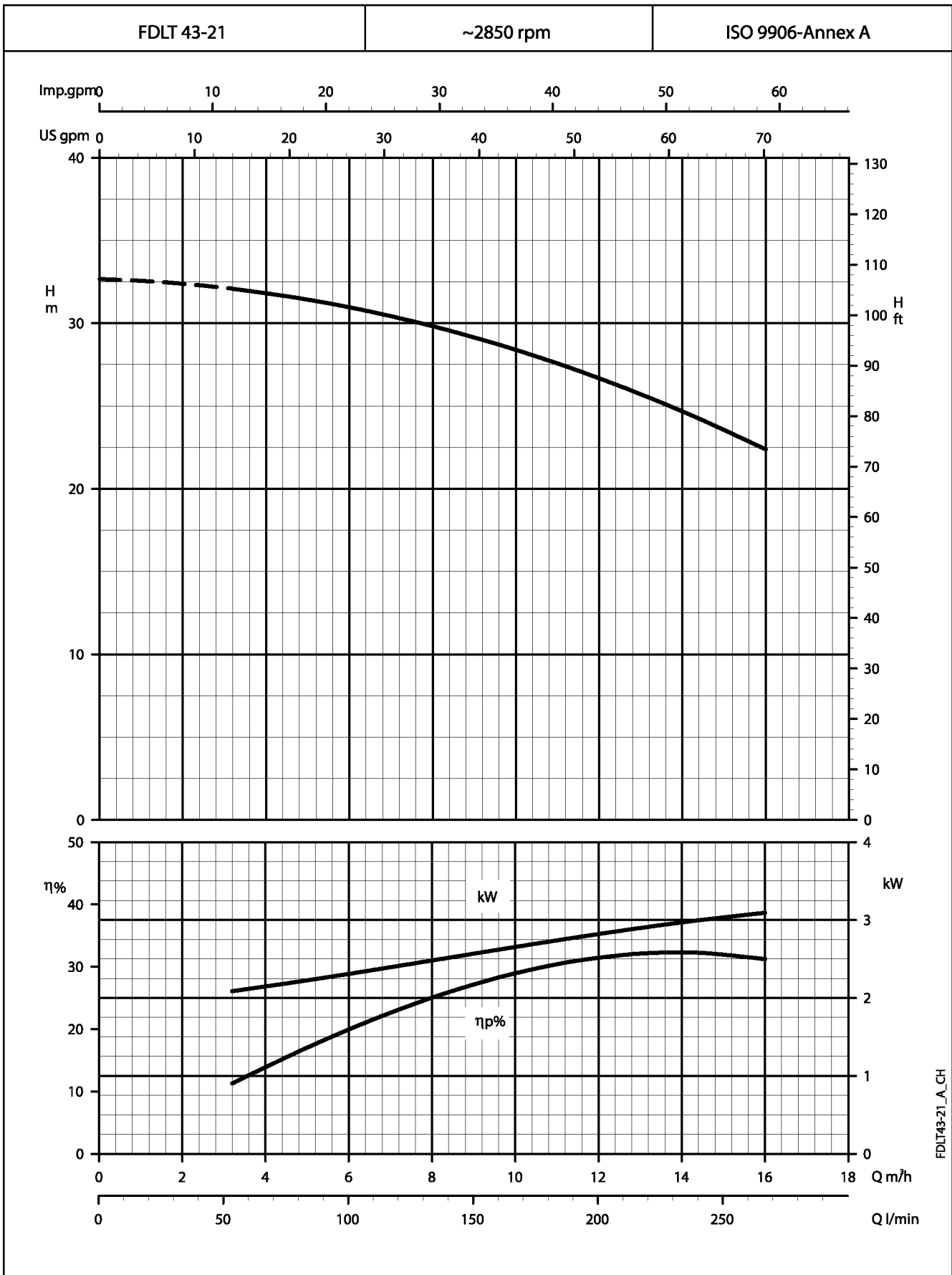

These performances are valid for liquids with density $\rho = 1.0 \text{ kg/dm}^3$ and kinematic viscosity $\gamma = 1 \text{ mm}^2/\text{s}$.

**FDLT SERIES
OPERATING CHARACTERISTICS AT 2850 rpm 50 Hz**

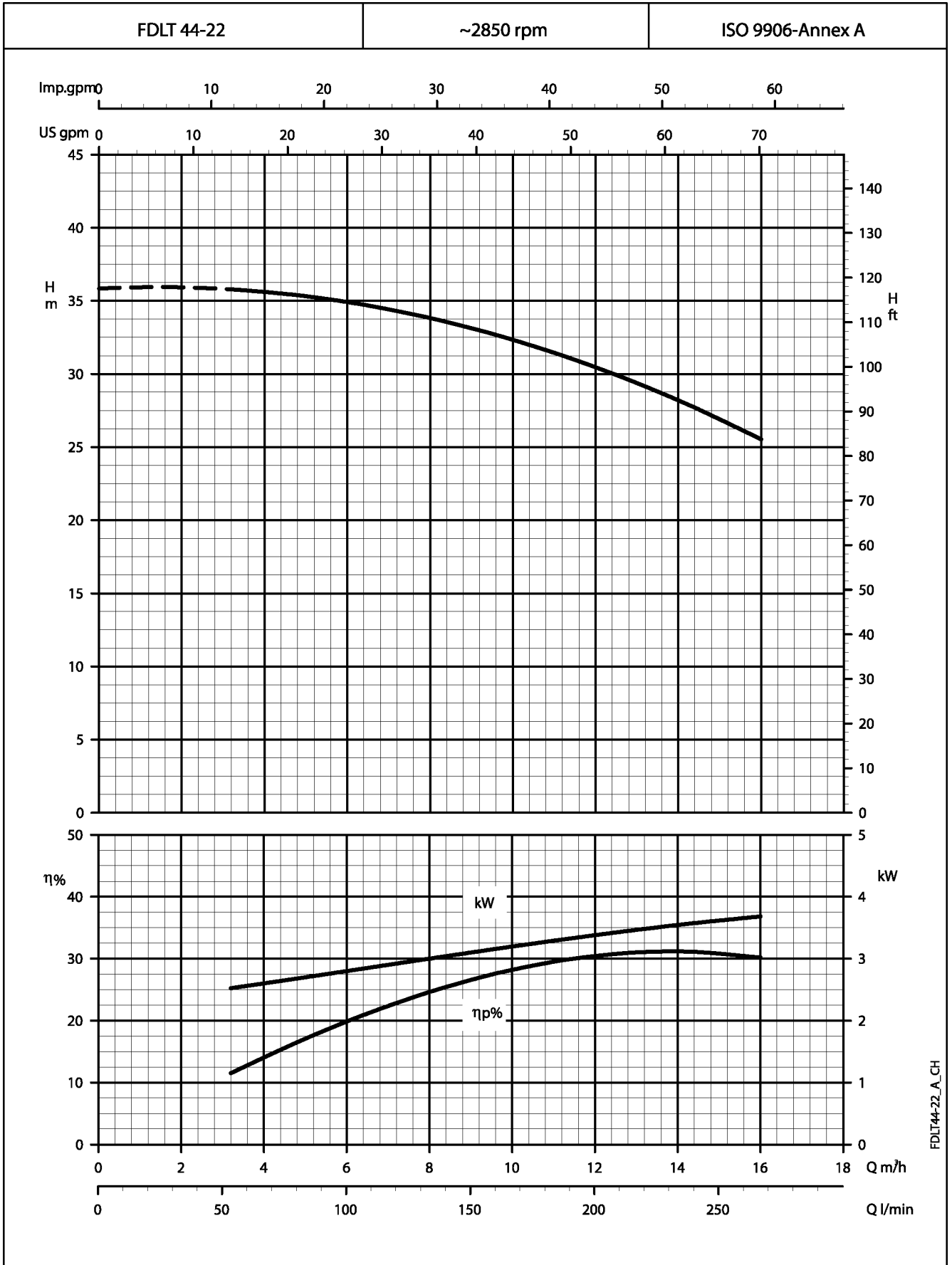

These performances are valid for liquids with density $\rho = 1.0 \text{ kg/dm}^3$ and kinematic viscosity $\gamma = 1 \text{ mm}^2/\text{s}$.

**FDLT SERIES
OPERATING CHARACTERISTICS AT 2850 rpm 50 Hz**

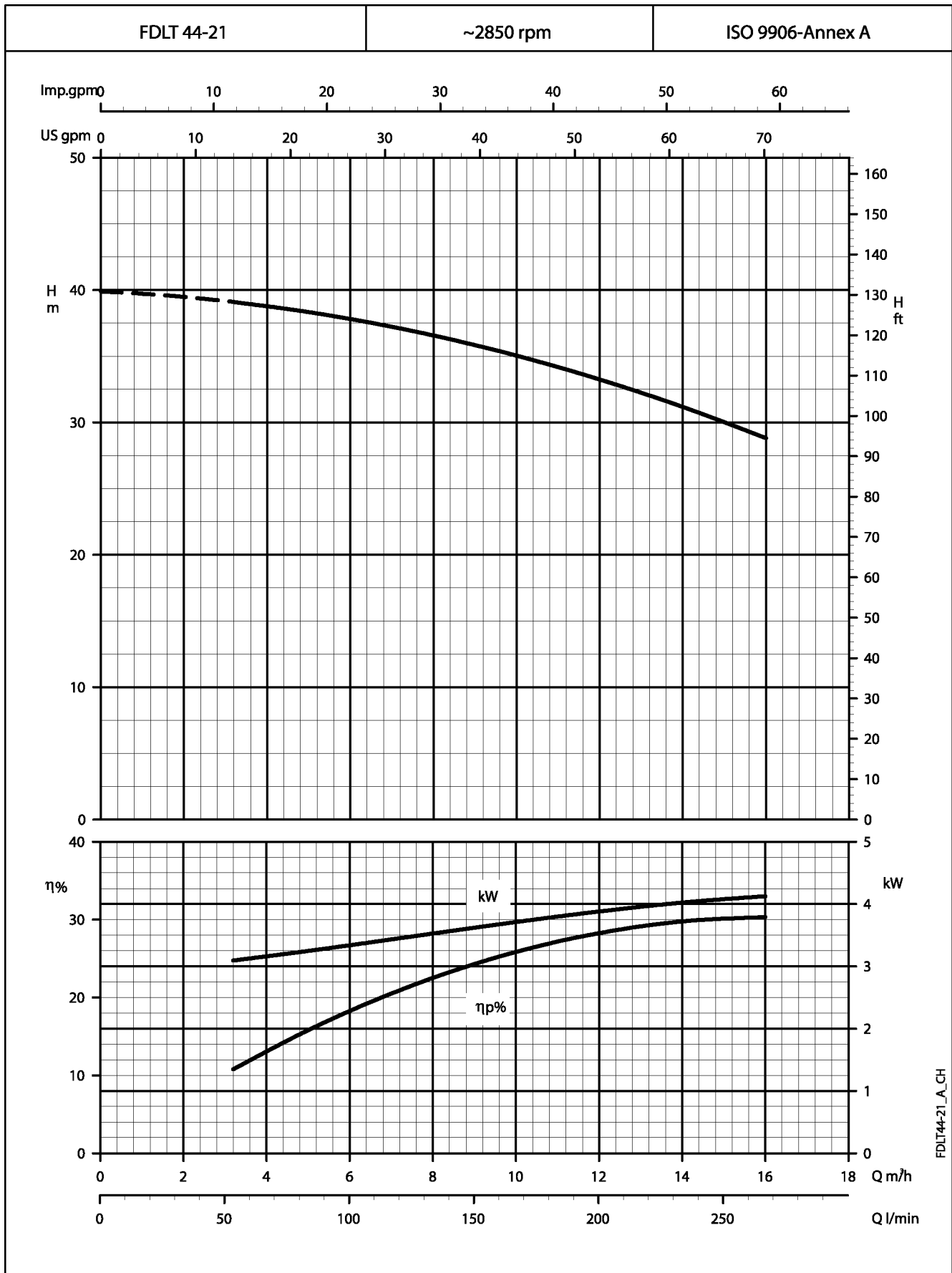

These performances are valid for liquids with density $\rho = 1.0 \text{ kg/dm}^3$ and kinematic viscosity $\nu = 1 \text{ mm}^2/\text{s}$.

**FDLT SERIES
OPERATING CHARACTERISTICS AT 2850 rpm 50 Hz**

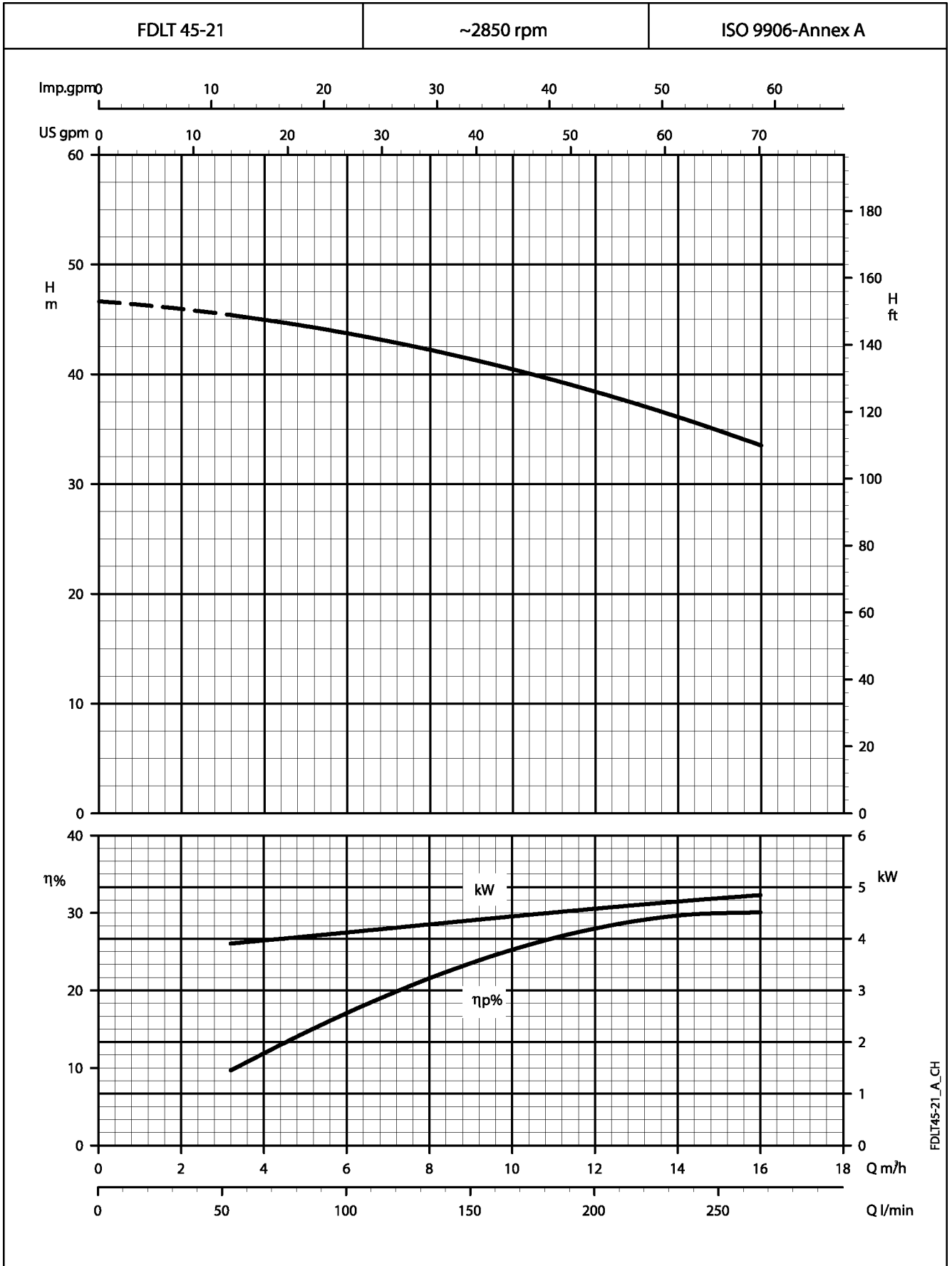

These performances are valid for liquids with density $\rho = 1.0 \text{ kg/dm}^3$ and kinematic viscosity $\gamma = 1 \text{ mm}^2/\text{s}$.

DIMENSIONS AND WEIGHTS, FDLT SERIES

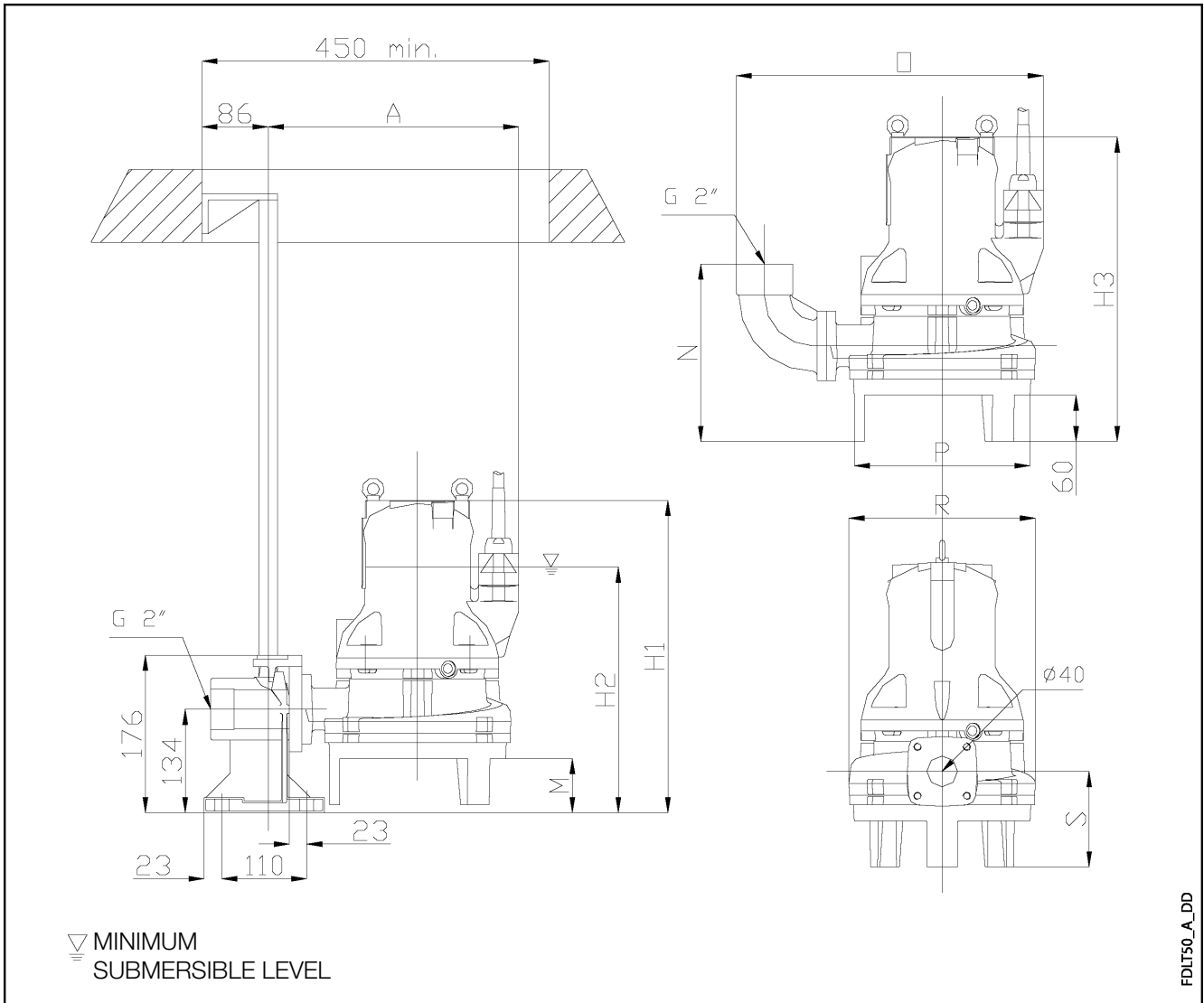

PUMP TYPE	DIMENSIONS (mm)										DNM	WEIGHT kg
	A	M	N	O	P	R	S	H1	H2	H3		
FDLMT 41-23	308	113	186	381	208	208	81	521	325	468	40	37
FDLMT 41-22	308	113	186	381	208	208	81	521	325	468	40	37
FDLMT 41-21	308	113	186	381	208	208	81	521	325	468	40	37
FDLMT 42-22	308	113	186	381	208	208	81	521	325	468	40	37
FDLMT 42-21	308	113	186	381	208	208	81	521	325	468	40	37
FDLT 41-23	308	113	186	381	208	208	81	521	325	468	40	37
FDLT 41-22	308	113	186	381	208	208	81	521	325	468	40	37
FDLT 41-21	308	113	186	381	208	208	81	521	325	468	40	37
FDLT 42-22	308	113	186	381	208	208	81	521	325	468	40	37
FDLT 42-21	308	113	186	381	208	208	81	521	325	468	40	37
FDLT 43-22	292	70	207	358	240	240	112	460	345	450	40	45
FDLT 43-21	292	70	207	358	240	240	112	460	345	450	40	45
FDLT 44-22	325	70	230	398	240	240	126	519	374	509	40	60
FDLT 44-21	325	70	230	398	240	240	126	519	374	509	40	60
FDLT 45-21	325	70	230	398	240	240	126	519	374	509	40	60

FDLT50_A_TD

**PUMP SECTION
FDLT SERIES**

FDLT

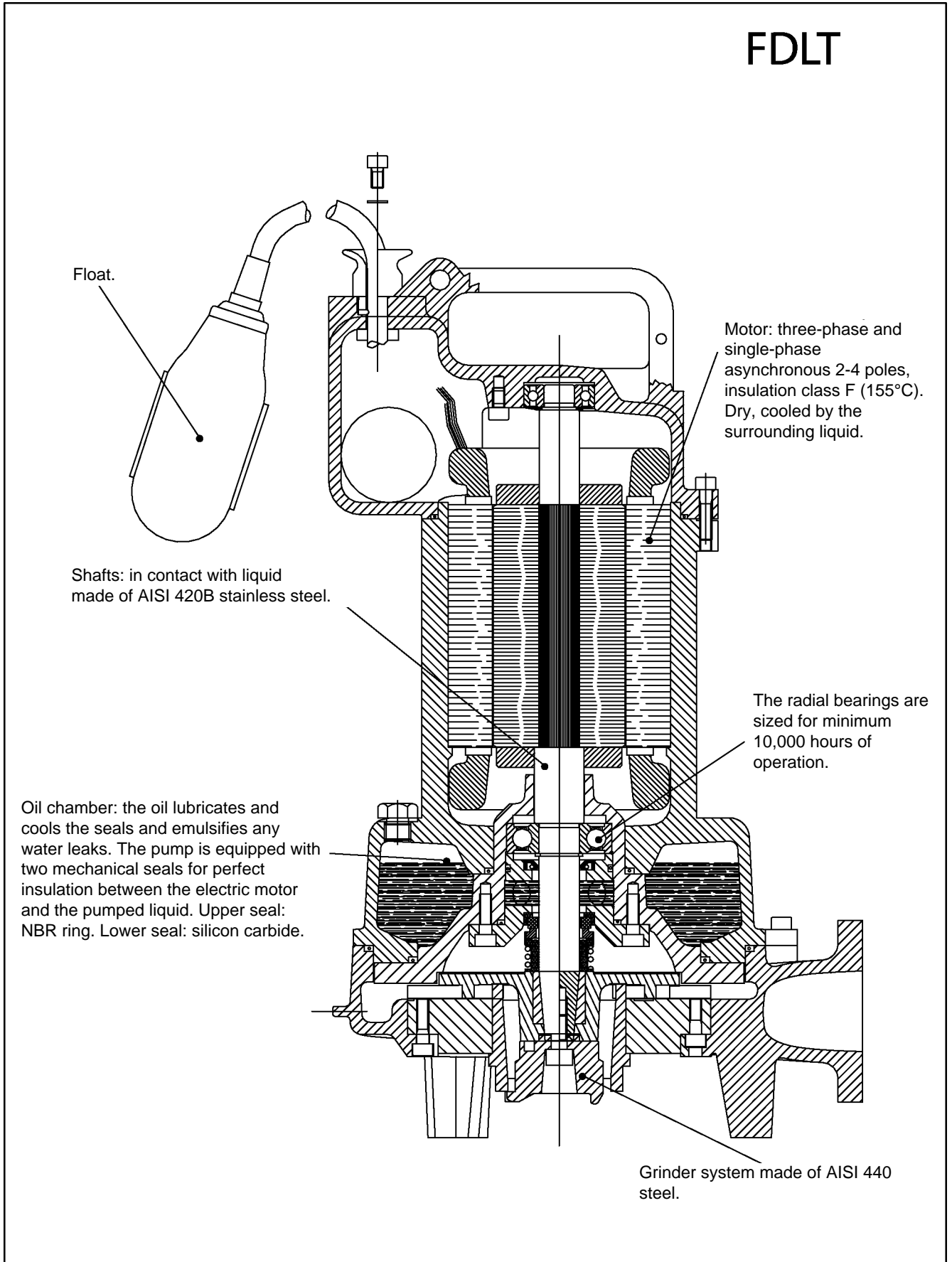

Submersible Electric Pumps

FXDL-FBDL Series



MARKET SECTORS

CHEMICAL, FOOD PROCESSING AND MARINE INDUSTRIES.

APPLICATIONS

- Pumping of chemically aggressive liquids, even those containing suspended solids (FXDL version), pumping of seawater.

SPECIFICATIONS

- **Delivery:** up to 108 m³/h.
- **Head:** up to 44 m.
- Maximum liquid **temperature:** 25-40°C (see hydraulic performance table).
- Maximum immersion depth: 20 m.
- **Passes solids** 6 to 30 mm in diameter (see hydraulic performance table).
- Motor with IP 68 protection and class F insulation (155°C) for the FBDL series, class H (170°C) for the FXDL series.
 - Power supply: three-phase, 50 Hz (also single-phase, 50 Hz for FBDL).
- **Motor power:** up to 7 kW.
- Maximum number of starts per hour: approx. 20 (possibly more, depending on the application).

CONSTRUCTION CHARACTERISTICS

- Sturdy construction with liquid end and casing made of AISI 316 stainless steel (FXDL) or B10 steel bronze (FBDL).
- Open **impeller**, vortex or channel type depending on the model.
- Double seal: Silicon Carbide / Silicon Carbide inner seal, Ceramic / Carbon upper seal or Nitrile Rubber seal ring with interposed oil chamber.
- Adjustable volute bottom cover to compensate for impeller wear and ensure stable long-lasting hydraulic performances.
- Oversized motor bearings.
- 10-metre power supply cable with neoprene sheath (H07RN-F).
- Moisture sensor in oil chamber (see electric data table).
- The FXDL models are equipped with threaded stainless steel cable gland for mounting a stainless steel tube for protection of the power cable.

OPTIONAL FEATURES

- Ceramic treatment
- Cooling sleeve for dry installations
- Versions without float.
- Flameproof construction (EEx).

ACCESSORIES / INSTALLATION

- Lowering system.
- 90° delivery union.
- Threaded flange for delivery port.
- Tripod stand.
- Non-return ball valves.
- Floats for solids-laden waters.
- Command and control panels.

IDENTIFICATION CODE

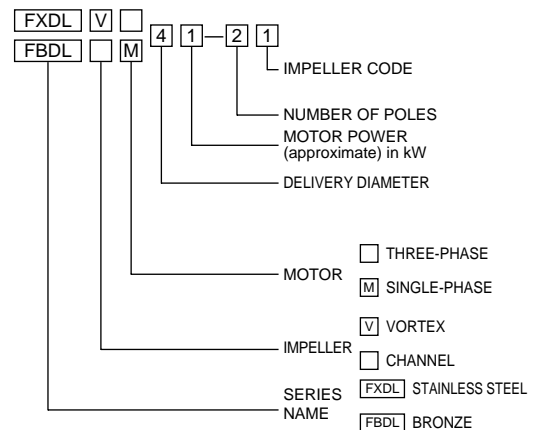

TABLE OF MATERIALS

PART	FDLT MATERIAL
Impeller, Pump body, Motor casing, Volute bottom, Upper cover	FXDL: STAINLESS STEEL (AISI 316) FBDL: B10 STEEL BRONZE
Shaft	STAINLESS STEEL (AISI 316L)
Bearings	LIFETIME LUBRICATED BALL TYPE
Upper seal	CERAMIC-GRAPHITE OR NITRILE RUBBER SEAL RING
Lower seal	FXDL: SILICON CARBIDE/SILICON CARBIDE FBDL: SILICON CARBIDE/SILICON CARBIDE
Gaskets	FXDL: FPM FBDL: NITRILE RUBBER
Bolts and screws	STAINLESS STEEL (AISI 316)

FXDL SERIES ELECTRICAL DATA (50 Hz)

PUMP TYPE	ABSORBED POWER*	rpm	ABSORBED CURRENT In(A)			STARTING CURRENT Isp (A)		ELECTRIC CABLE TYPE	STATOR THERMAL PROTECTION**	WATER SENSOR IN OIL CHAMBER**
			220-240 V	380-415 V		220-240 V	380-415 V			
			Δ	Y	Δ	A	A			
DRAINAGE IMPELLER										
FXDL 41-21	1	2850	3,3	1,9		15,1	8,7	4G1,5	NO	NO
FXDL 53-22	3,2	2850	9,5	5,5		55,2	31,9	4G2,5	NO	NO
FXDL 56-23	6	2850	17,5		10,1	115,3	66,7	12G1,5	YES	YES
FXDL 56-22	6,6	2850	19,7		11,4	130,2	75,2	12G1,5	YES	YES
FXDL 56-21	9	2850	22,1		12,8	146,2	84,5	12G1,5	YES	YES
SINGLE-CHANNEL IMPELLER										
FXDL 62-22	1,7	2850	5,0	2,9		18,6	10,7	4G2,5	NO	NO
FXDL 62-21	2,2	2850	6,4	3,7		37,1	21,5	4G2,5	NO	NO
MULTIPLE-CHANNEL IMPELLER										
FXDL 64-22	3,8	2850	11,6	6,7		67,2	38,9	4G2,5	NO	NO
FXDL 65-22	5,2	2850	15,2		8,8	99,0	57,2	12G1,5	YES	YES
FXDL 66-21	6,6	2850	19,0		11	123,7	71,5	12G1,5	YES	YES
VORTEX IMPELLER										
FXDLV 41-21	0,8	2850	3,1	1,8		14,3	8,3	4G1,5	NO	NO

*Maximum values within the operating range

Fxdl-2p50_b_te

**Featured in the standard version

FBDL SERIES ELECTRICAL DATA (50 Hz)

PUMP TYPE	ABSORBED POWER*	rpm	ABSORBED CURRENT In(A)			STARTING CURRENT Isp (A)		ELECTRIC CABLE TYPE	STATOR THERMAL PROTECTION**	WATER SENSOR IN OIL CHAMBER**
			220-240 V	380-415 V		220-240 V	380-415 V			
			Δ	Y	Δ	A	A			
SINGLE-CHANNEL IMPELLER										
FBDL 62-22	1,7	2850	5,0	2,9		18,6	10,7	4G2,5	NO	NO
FBDL 62-21	2,2	2850	6,4	3,7		36,5	21,1	4G2,5	NO	NO
MULTIPLE-CHANNEL IMPELLER										
FBDL 64-22	3,5	2850	10,0	5,8		58,2	33,6	4G2,5	NO	NO
FBDL 65-22	5,2	2850	15,2		8,8	99,0	57,2	12G1,5	YES	YES
FBDL 66-21	6,6	2850	19,0		11	123,7	71,5	12G1,5	YES	YES
FBDLV 40-21	0,5	2850	1,7	1		6,4	3,7	4G1	NO	NO

PUMP TYPE	ABSORBED POWER*	rpm	ABSORBED CURRENT In(A) 220-240 V	CAPACITOR		STARTING CURRENT A	ELECTRIC CABLE TYPE	STATOR THERMAL PROTECTION	WATER SENSOR IN OIL CHAMBER
				μf	V				
SINGLE-CHANNEL IMPELLER									
FBDLM 62-22	1,8	2850	8,7	35	450	35,7	4G2,5	NO	NO
VORTEX IMPELLER									
FBDLVM 40-21	0,5	2850	2,3	35	450	7,1	3G1	YES	NO

*Maximum values within the operating range

Fbdl-2p50_b_te

**Featured in the standard version

**FXDL SERIES
OPERATING CHARACTERISTICS AT 50 Hz**

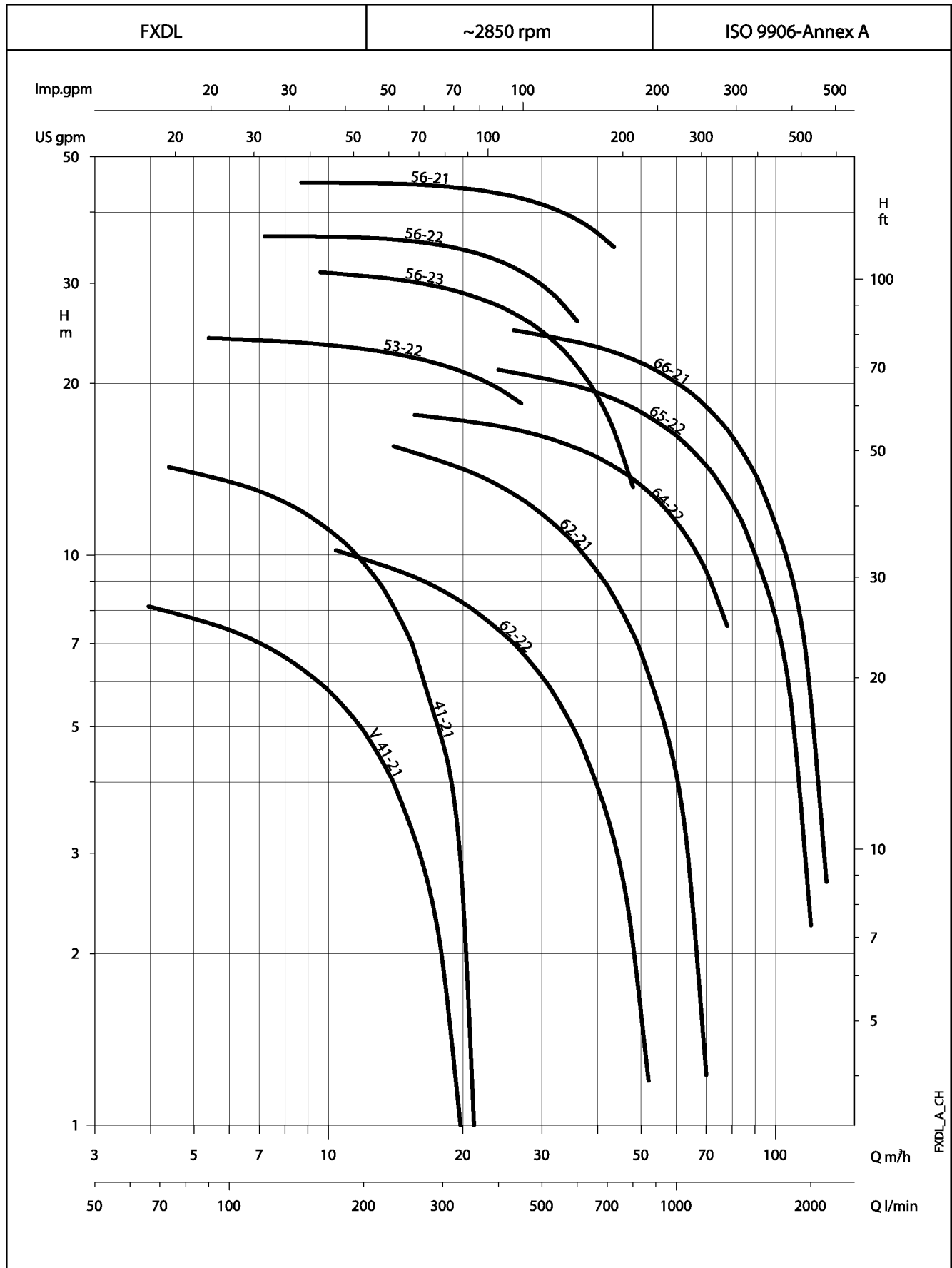

**FBDL SERIES
OPERATING CHARACTERISTICS AT 50 Hz**

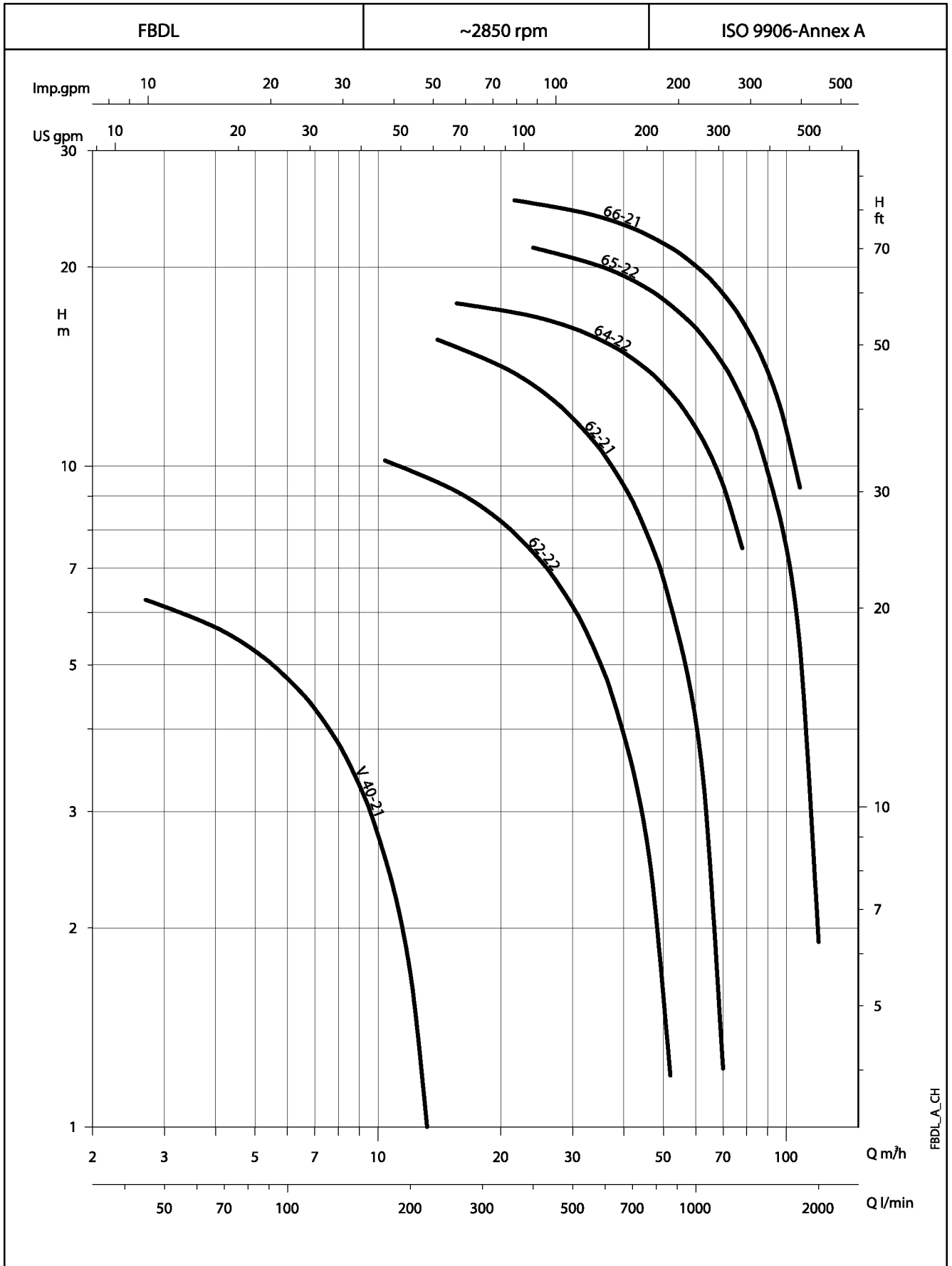

FXDL SERIES HYDRAULIC PERFORMANCE TABLE

PUMP TYPE	ABS. POW. kW	rpm	Q = DELIVERY												DNM	PASSES SOLIDS UP TO (mm)	MAX LIQUID TEMP. °C
			l/min 0	50	100	150	200	300	400	600	800	1000	1200				
			m ³ /h 0	3	6	9	12	18	24	36	48	60	72				
H = TOTAL HEAD METERS COLUMN OF WATER																	
FXDLV 41-21	0,8	2850	9,4	8,5	7,4	6,2	4,9	2,0						Rp 1 1/2	30	40	
FXDL 41-21	1,0	2850	16,0	14,9	13,5	11,8	9,7	4,6						Rp 1 1/2	6	40	
FXDL 53-22	3,2	2850	24,4	24,3	24,0	23,5	23,0	21,5	19,6					Rp 2	7	40	
FXDL 62-22	1,7	2850	12,2	11,6	11,1	10,5	9,9	8,7	7,4	4,8	2,1			70	28	40	
FXDL 62-21	2,2	2850	18,5	17,9	17,3	16,6	16,0	14,6	13,3	10,4	7,3	4,1		70	30	40	
FXDL 64-22	3,8	2850	18,6	18,5	18,3	18,1	17,9	17,4	16,8	15,4	13,6	11,4	8,9	70	30	25	
FXDL 56-23	6,0	2850	32,1	32,0	31,8	31,4	30,9	29,5	27,4	21,5	13,2			Rp 2	8	40	
FXDL 56-22	6,6	2850	35,3	35,9	36,2	36,2	36,0	34,9	32,9	25,7				Rp 2	8	40	
FXDL 56-21	9,0	2850	44,3	44,7	44,9	45,0	45,0	44,4	43,1	38,8				Rp 2	8	40	

PUMP TYPE	ABS. POW. kW	rpm	Q = DELIVERY												DNM	PASSES SOLIDS UP TO (mm)	MAX LIQUID TEMP. °C
			l/min 0	200	300	400	600	800	1000	1200	1400	1600	1800				
			m ³ /h 0	12	18	24	36	48	60	72	84	96	108				
H = TOTAL HEAD METERS COLUMN OF WATER																	
FXDL 65-22	5,2	2850	23,0	22,2	21,7	21,1	19,8	18,1	16,2	14,0	11,5	8,7	5,6	70	30	40	
FXDL 66-21	6,6	2850	26,7	26,0	25,6	25,0	23,7	22,0	20,1	17,9	15,3	12,4	9,3	70	30	40	

PERFORMANCES MEASURED WITH PURE WATER AT 20°C

FXDL_B_TH

FBDL SERIES HYDRAULIC PERFORMANCE TABLE

PUMP TYPE	ABS. POW. kW	rpm	Q = DELIVERY												DNM	PASSES SOLIDS UP TO (mm)	MAX LIQUID TEMP. °C
			l/min 0	50	75	100	150	175	200	250	400	600	1000				
			m ³ /h 0	3	4,5	6	9	10,5	12	15	24	36	60				
H = TOTAL HEAD METERS COLUMN OF WATER																	
FBDLVM 40-21	0,5	2850	8,4	7,0	6,3	5,6	4,0	3,2	2,3					Rp 1 1/4	30	40	
FBDLM 62-22	1,8	2850	12,4	11,7	11,4	11,1	10,5	10,1	9,8	9,2	7,2	4,6		70	28	25	
FBDLV 40-21	0,5	2850	7,4	6,1	5,5	4,8	3,3	2,5	1,7					Rp 1 1/4	30	40	
FBDL 62-22	1,7	2850	12,2	11,6	11,3	11,1	10,5	10,2	9,9	9,3	7,4	4,8		70	28	40	
FBDL 62-21	2,2	2850	18,5	17,9	17,6	17,3	16,6	16,3	16,0	15,3	13,3	10,4	4,1	70	30	40	

PUMP TYPE	ABS. POW. kW	rpm	Q = DELIVERY												DNM	PASSES SOLIDS UP TO (mm)	MAX LIQUID TEMP. °C
			l/min 0	125	175	250	400	600	800	1000	1200	1400	1800				
			m ³ /h 0	7,5	10,5	15	24	36	48	60	72	84	108				
H = TOTAL HEAD METERS COLUMN OF WATER																	
FBDL 64-22	3,5	2850	18,6	18,2	18,0	17,7	16,8	15,4	13,6	11,4	8,9			70	30	25	
FBDL 65-22	5,2	2850	23,5	22,9	22,7	22,3	21,4	19,9	18,2	16,2	13,9	11,3	5,3	70	30	40	
FBDL 66-21	6,6	2850	26,7	26,3	26,1	25,8	25,0	23,7	22,0	20,1	17,9	15,3	9,3	70	30	40	

PERFORMANCES MEASURED WITH PURE WATER AT 20°C

FBDL_B_TH

**FXDL SERIES
OPERATING CHARACTERISTICS AT 2850 rpm 50 Hz**

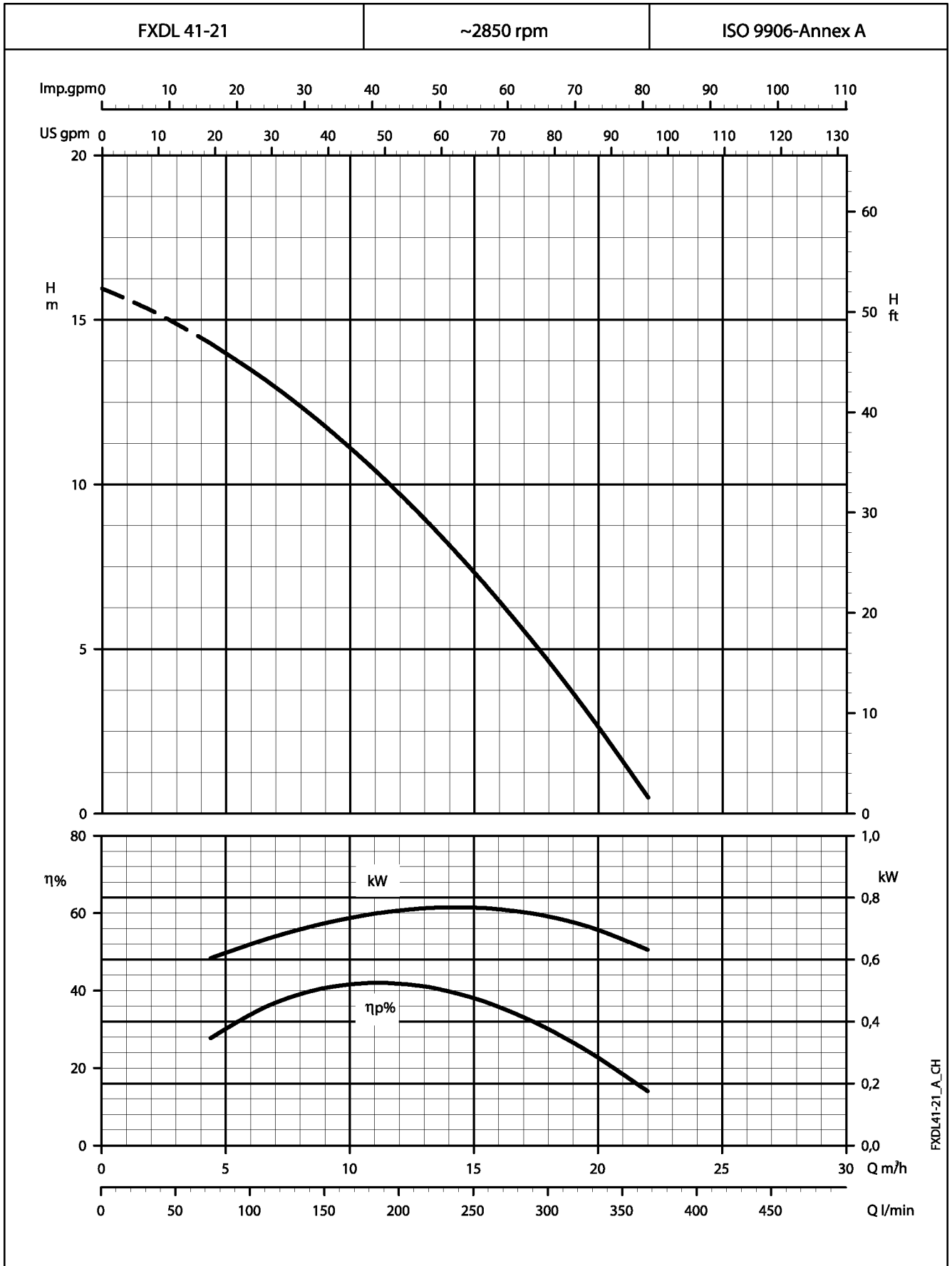

These performances are valid for liquids with density $\rho = 1.0 \text{ kg/dm}^3$ and kinematic viscosity $\gamma = 1 \text{ mm}^2/\text{s}$.

**FXDL SERIES
OPERATING CHARACTERISTICS AT 2850 rpm 50 Hz**

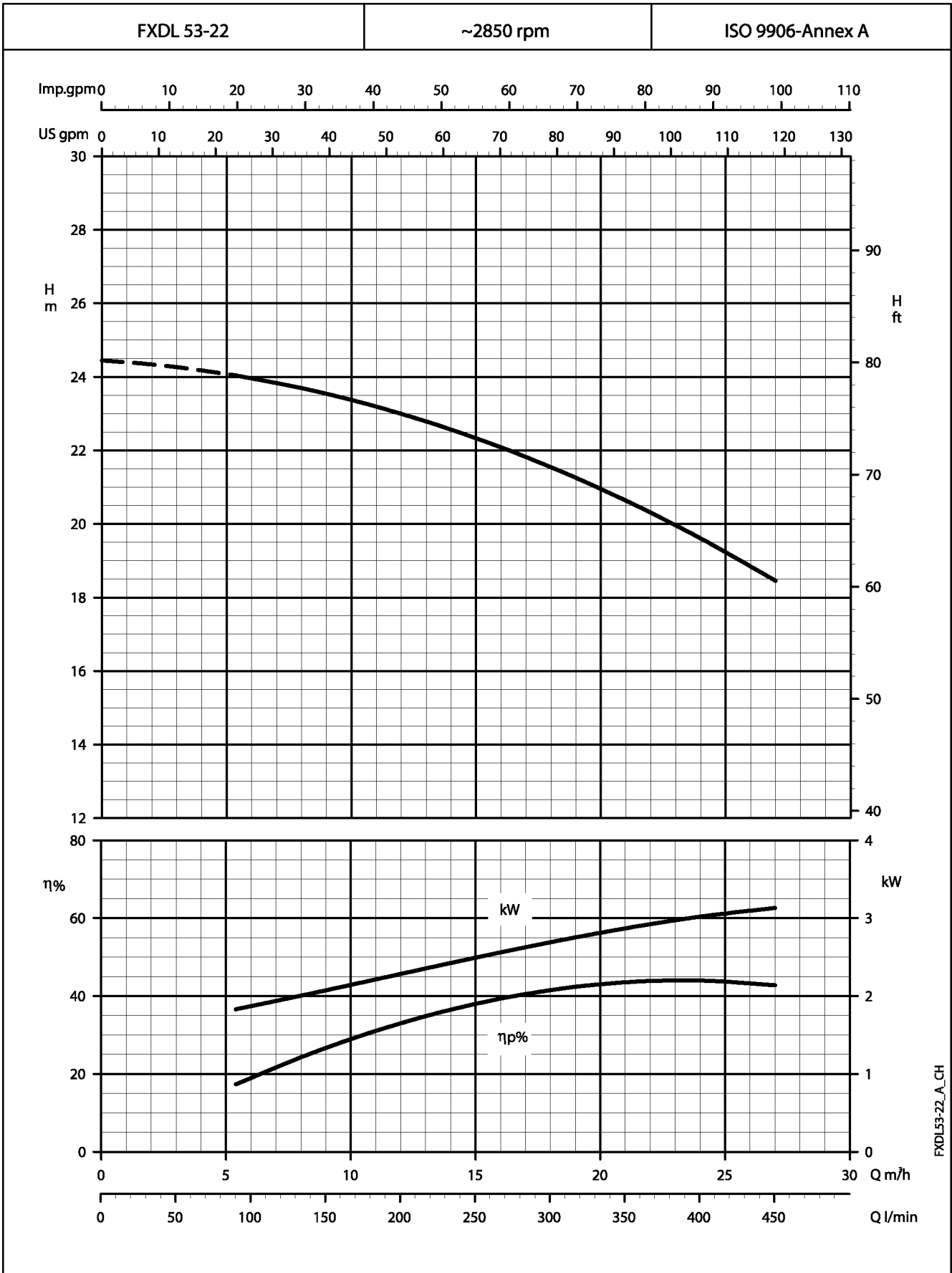

These performances are valid for liquids with density $\rho = 1.0 \text{ kg/dm}^3$ and kinematic viscosity $\gamma = 1 \text{ mm}^2/\text{s}$.

**FXDL SERIES
OPERATING CHARACTERISTICS AT 2850 rpm 50 Hz**

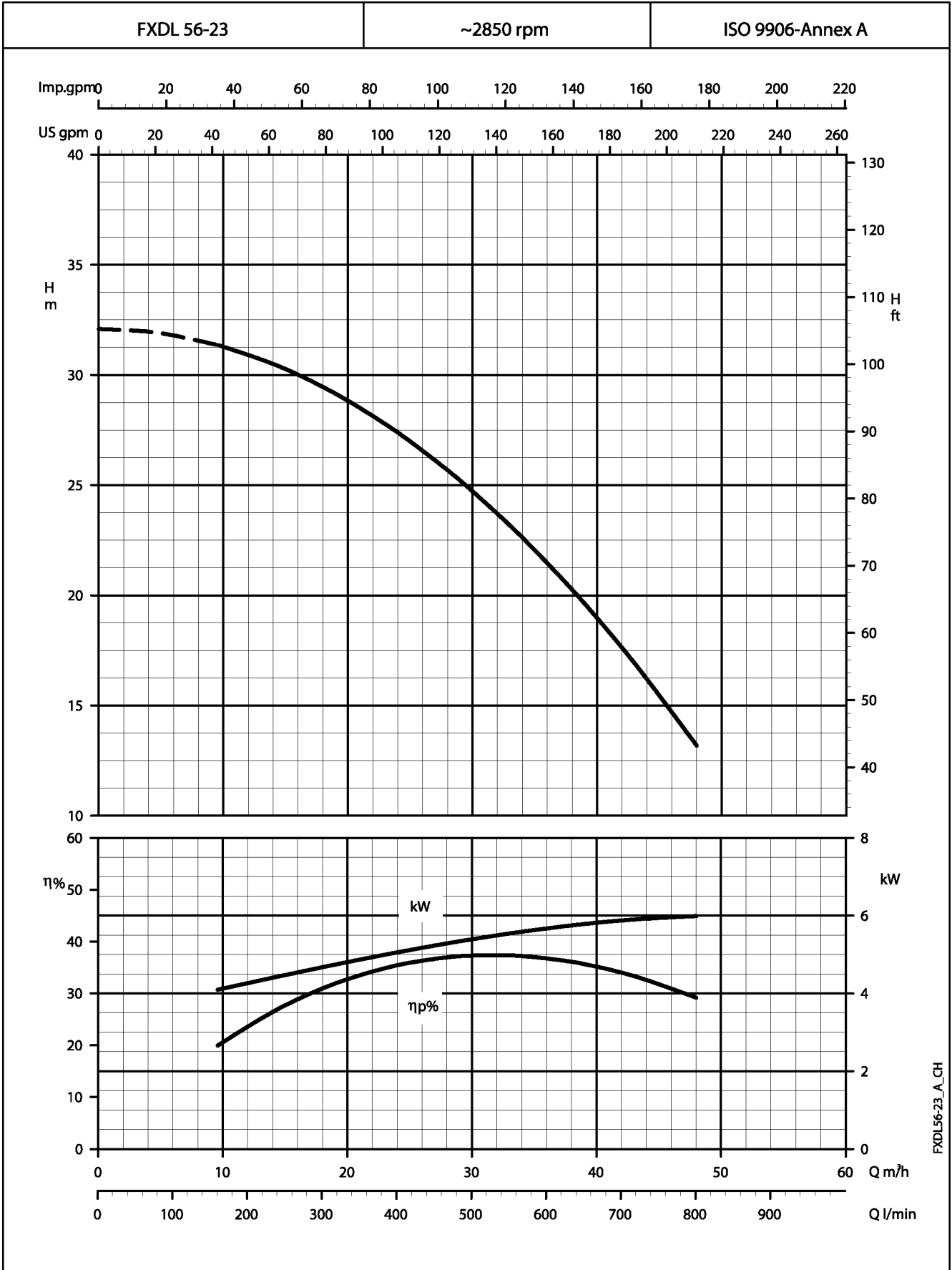

These performances are valid for liquids with density $\rho = 1.0 \text{ kg/dm}^3$ and kinematic viscosity $\gamma = 1 \text{ mm}^2/\text{s}$.

**FXDL SERIES
OPERATING CHARACTERISTICS AT 2850 rpm 50 Hz**

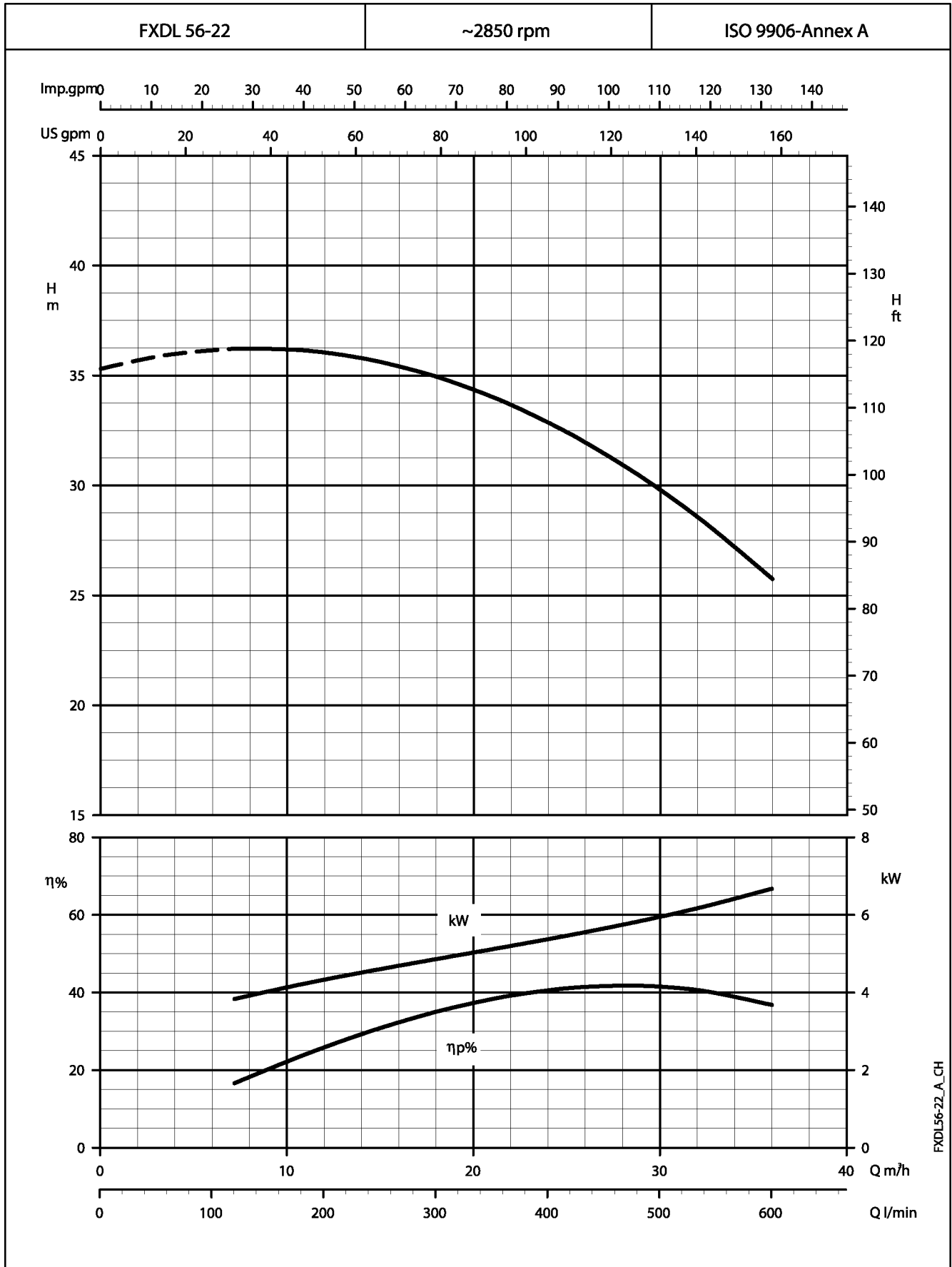

These performances are valid for liquids with density $\rho = 1.0 \text{ kg/dm}^3$ and kinematic viscosity $\nu = 1 \text{ mm}^2/\text{s}$.

**FXDL SERIES
OPERATING CHARACTERISTICS AT 2850 rpm 50 Hz**

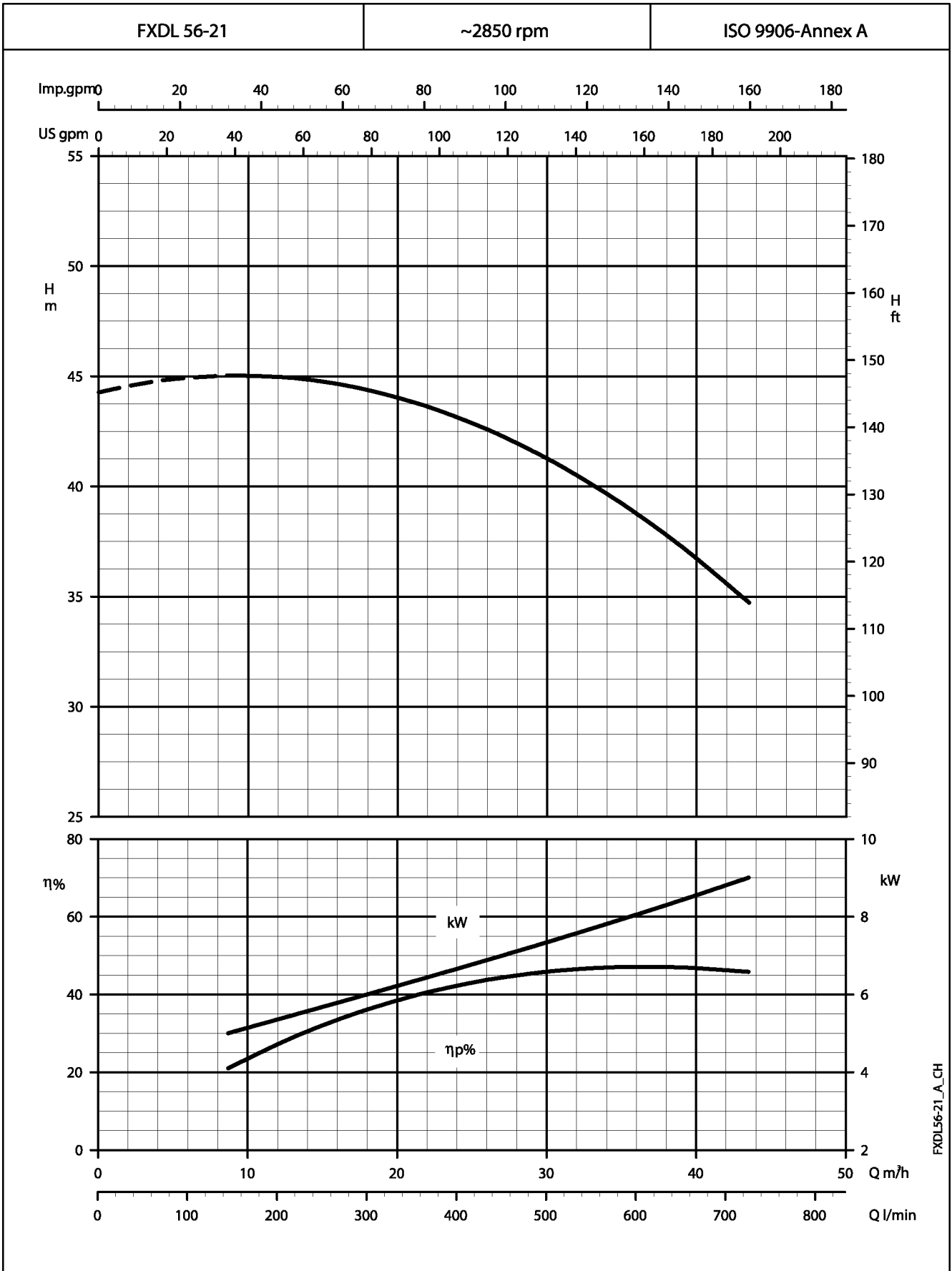

These performances are valid for liquids with density $\rho = 1.0 \text{ kg/dm}^3$ and kinematic viscosity $\gamma = 1 \text{ mm}^2/\text{s}$.

**FXDL SERIES
OPERATING CHARACTERISTICS AT 2850 rpm 50 Hz**

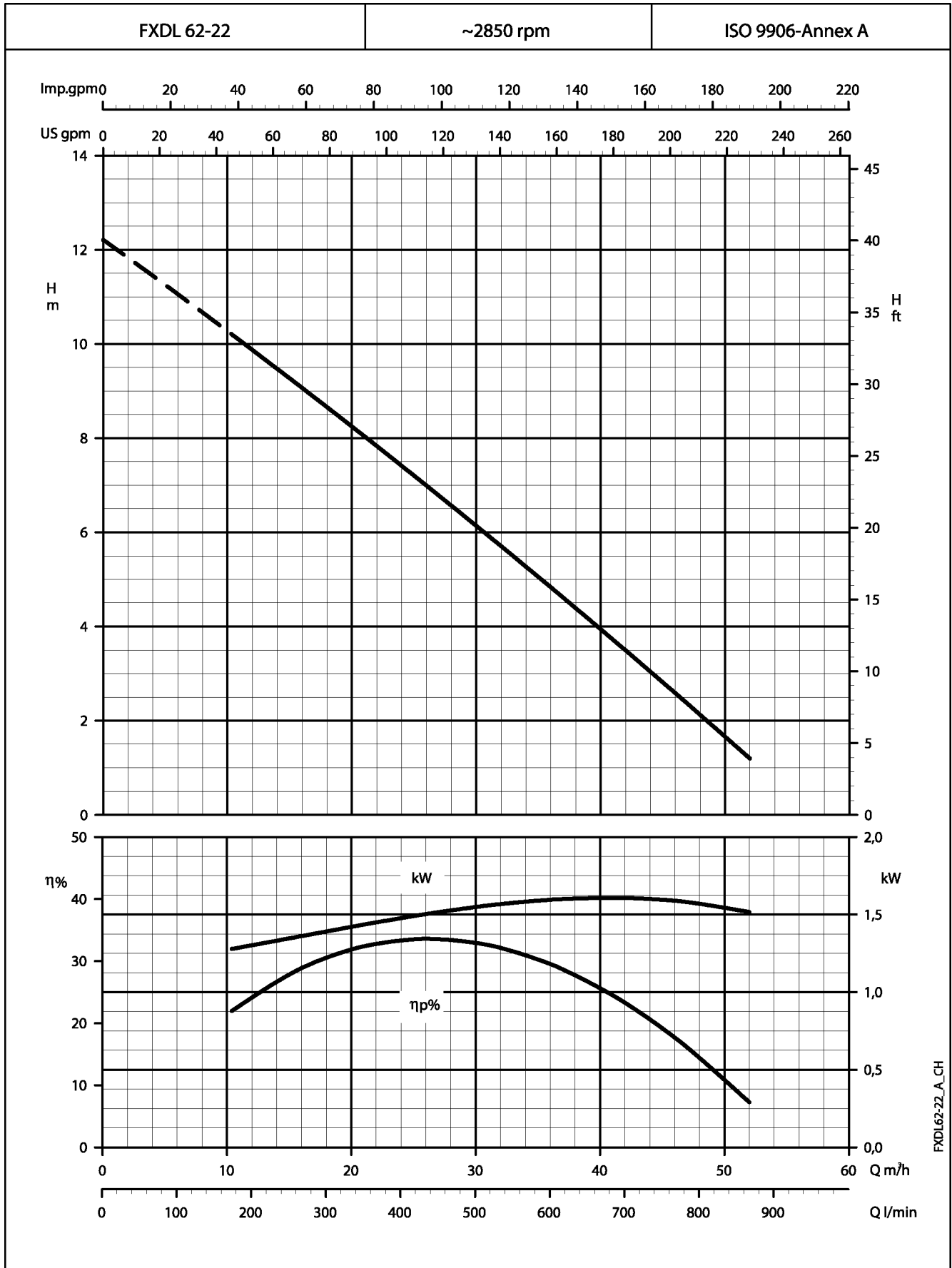

These performances are valid for liquids with density $\rho = 1.0 \text{ kg/dm}^3$ and kinematic viscosity $\nu = 1 \text{ mm}^2/\text{s}$.

**FXDL SERIES
OPERATING CHARACTERISTICS AT 2850 rpm 50 Hz**

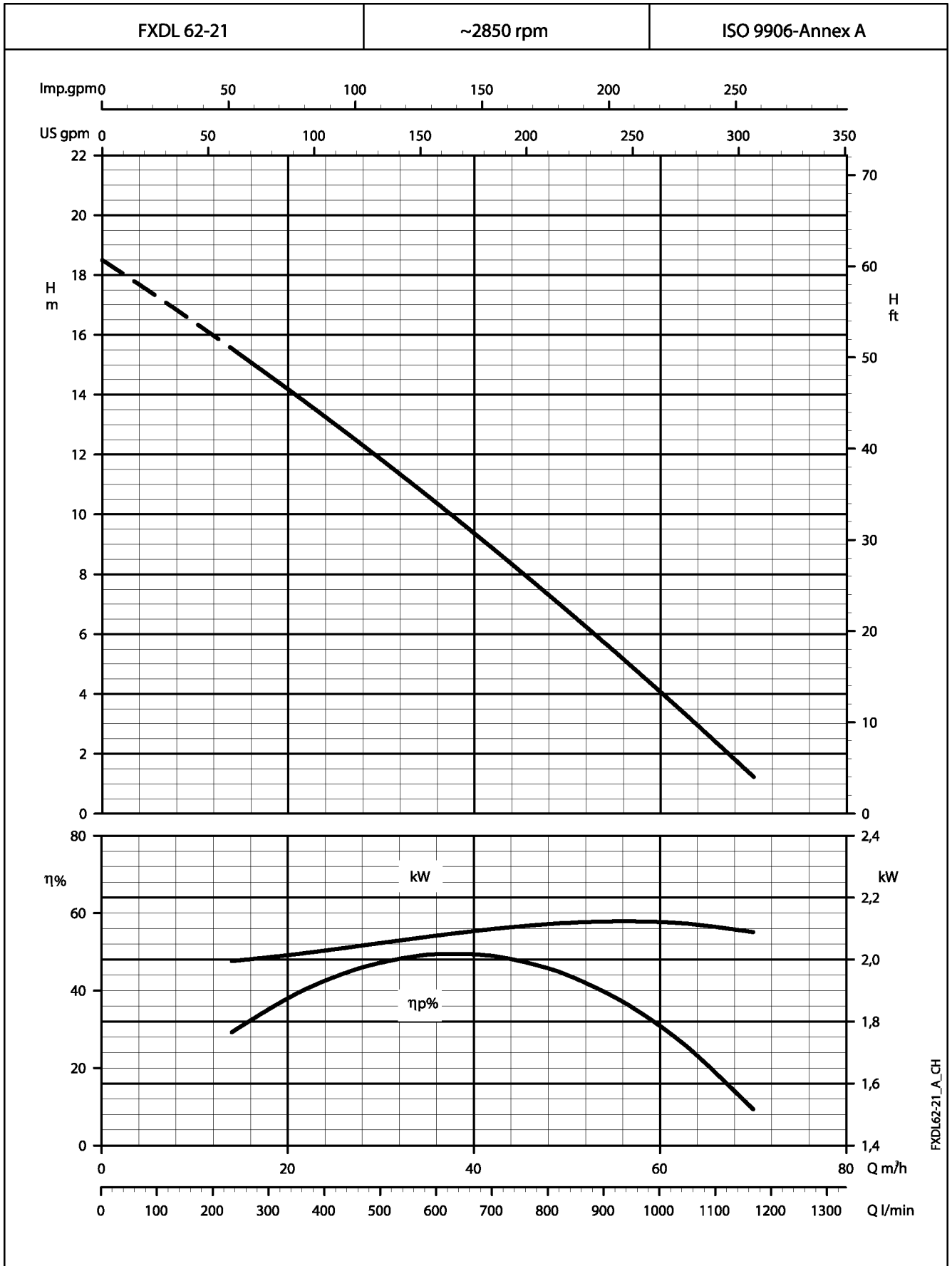

These performances are valid for liquids with density $\rho = 1.0 \text{ kg/dm}^3$ and kinematic viscosity $\gamma = 1 \text{ mm}^2/\text{s}$.

**FXDL SERIES
OPERATING CHARACTERISTICS AT 2850 rpm 50 Hz**

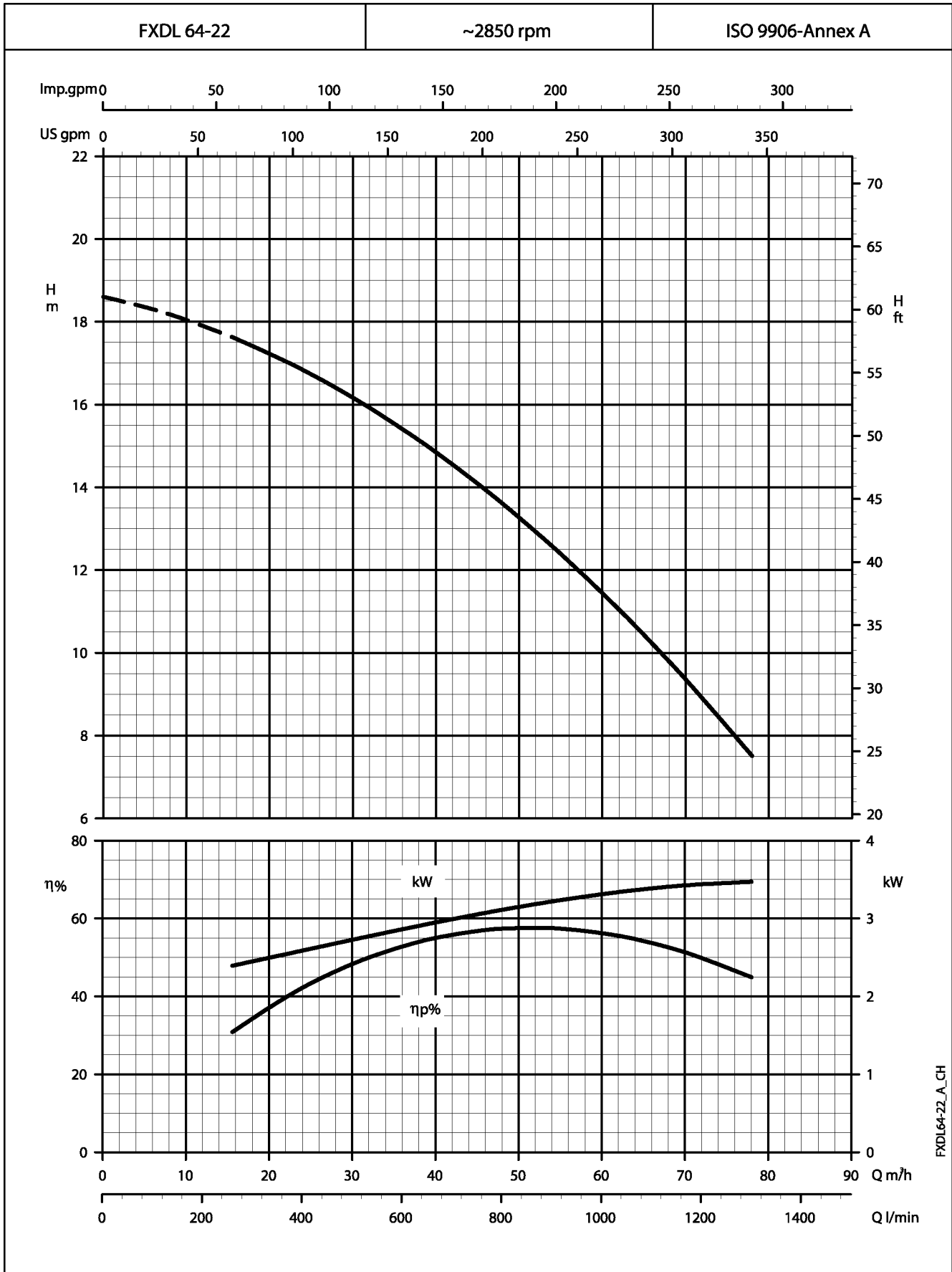

These performances are valid for liquids with density $\rho = 1.0 \text{ kg/dm}^3$ and kinematic viscosity $\gamma = 1 \text{ mm}^2/\text{s}$.

**FXDL SERIES
OPERATING CHARACTERISTICS AT 2850 rpm 50 Hz**

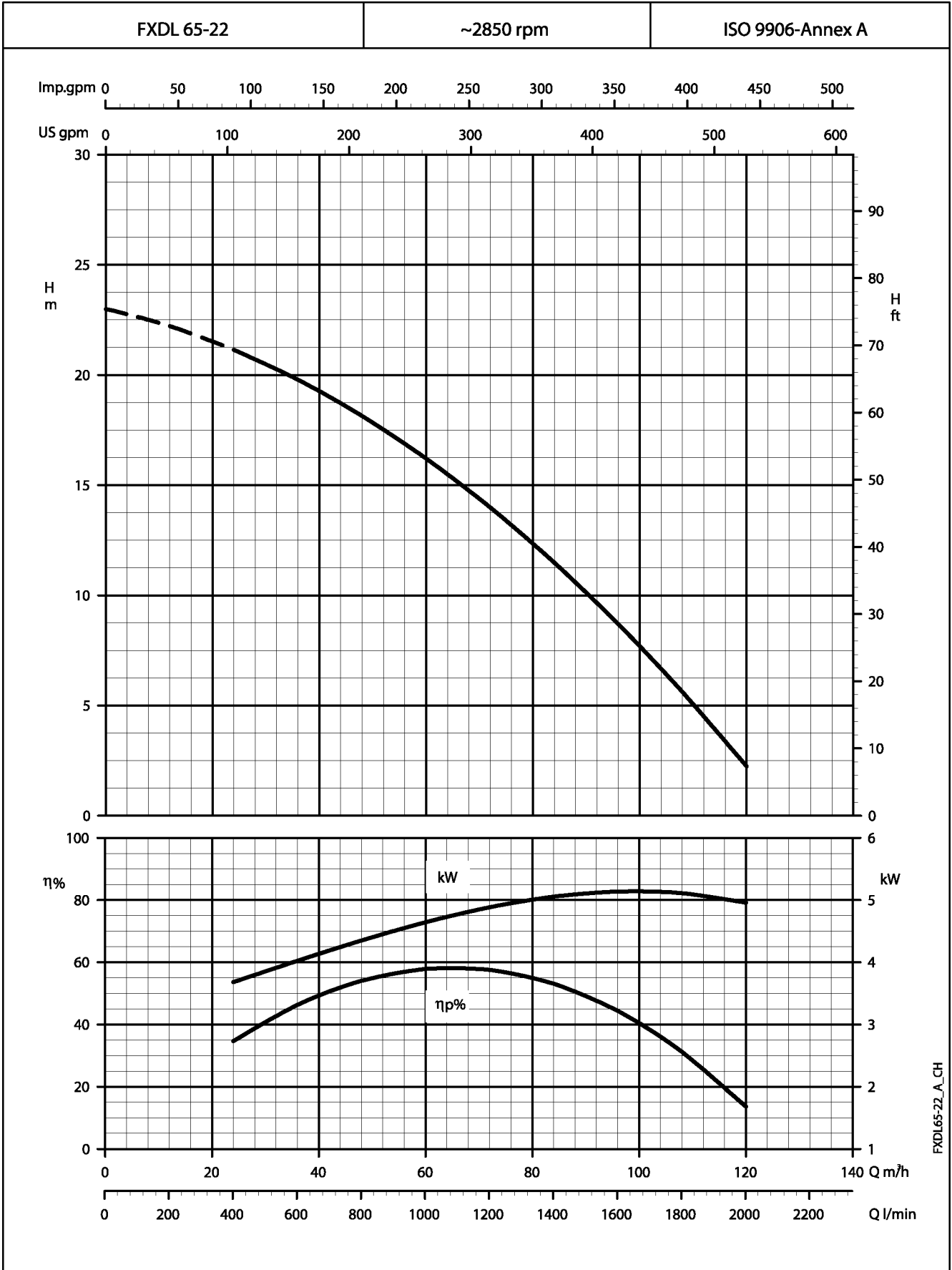

These performances are valid for liquids with density $\rho = 1.0 \text{ kg/dm}^3$ and kinematic viscosity $\gamma = 1 \text{ mm}^2/\text{s}$.

**FXDL SERIES
OPERATING CHARACTERISTICS AT 2850 rpm 50 Hz**

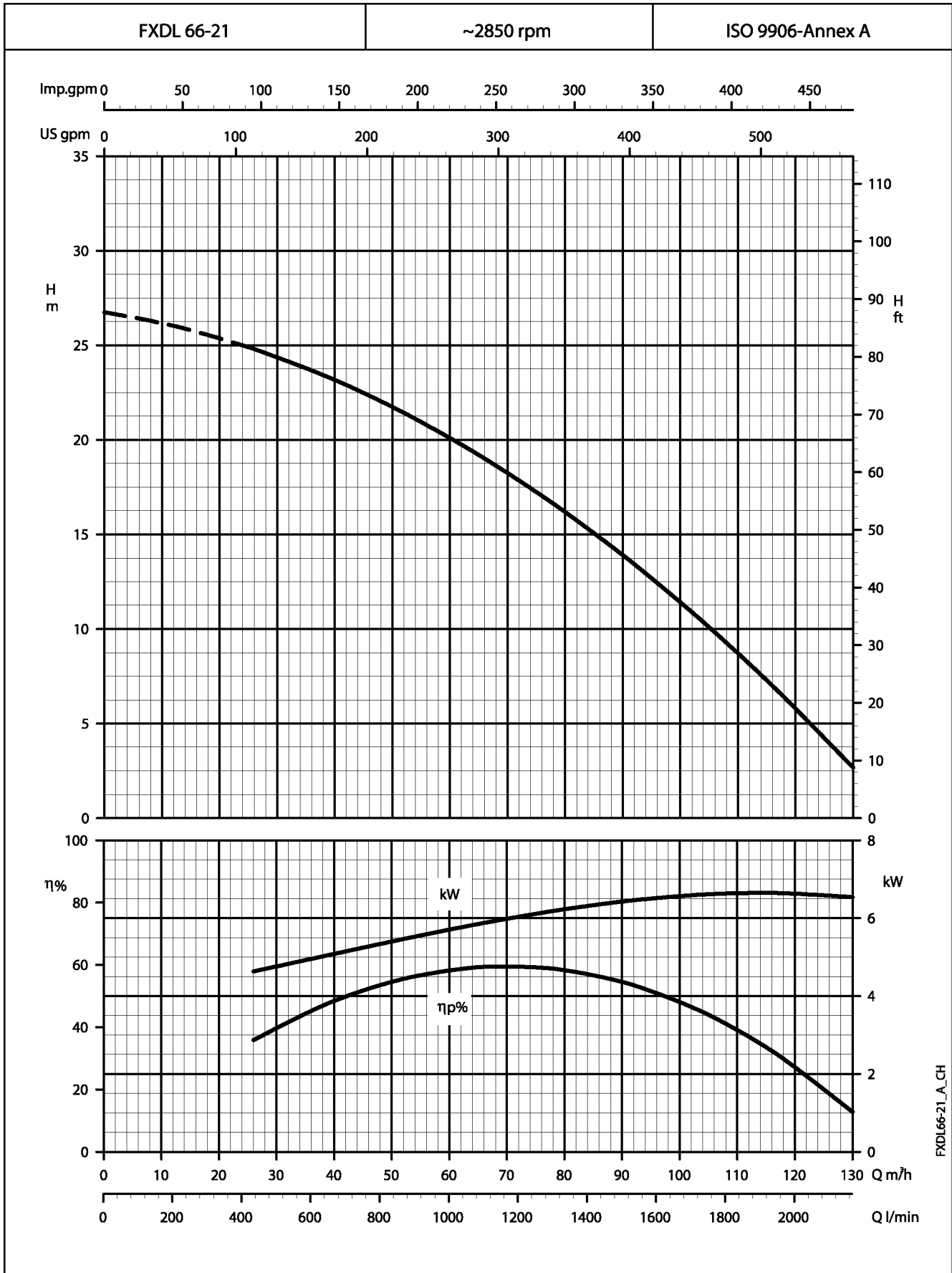

These performances are valid for liquids with density $\rho = 1.0 \text{ kg/dm}^3$ and kinematic viscosity $\gamma = 1 \text{ mm}^2/\text{s}$.

**FXDL SERIES
OPERATING CHARACTERISTICS AT 2850 rpm 50 Hz**

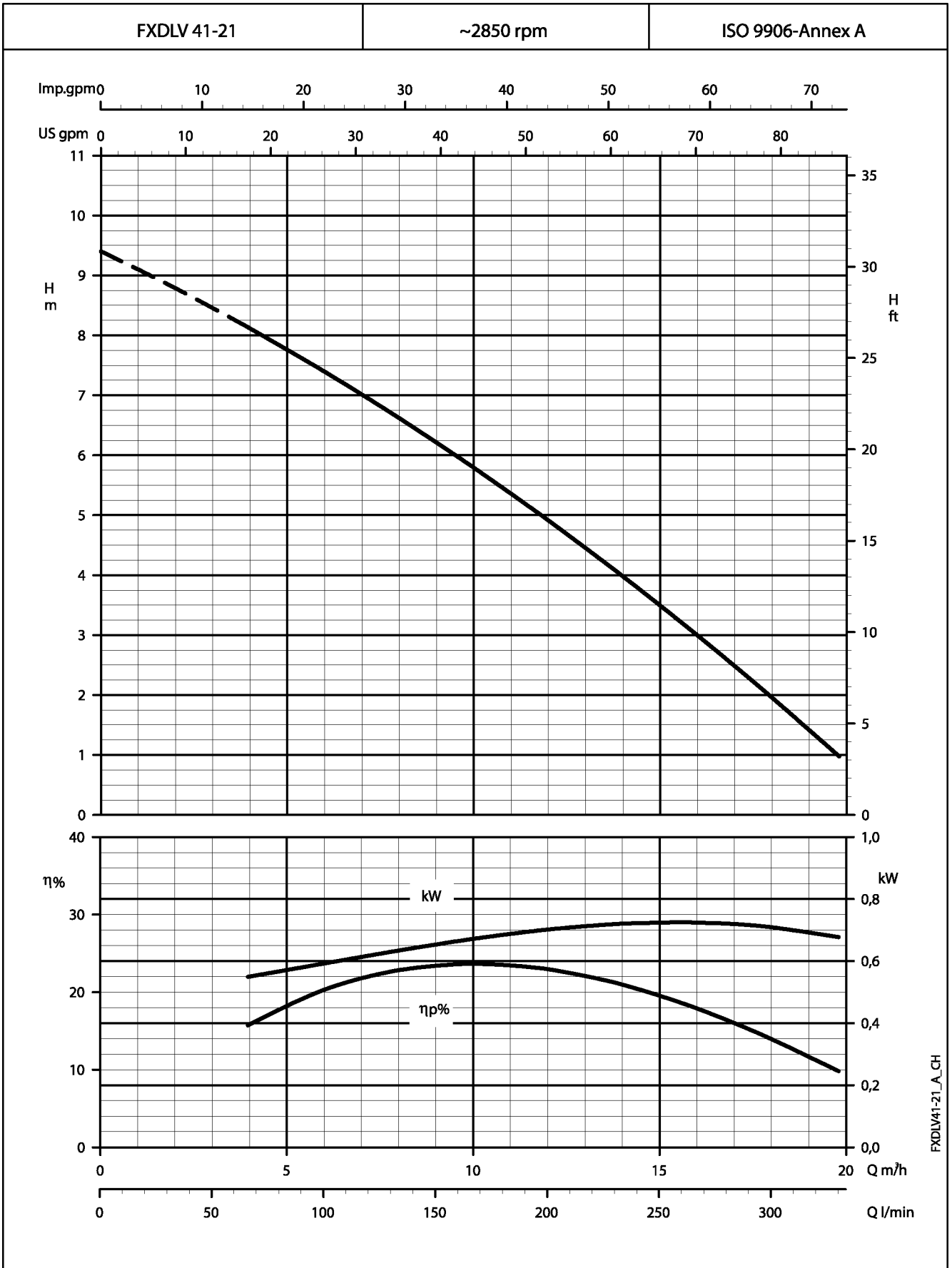

These performances are valid for liquids with density $\rho = 1.0 \text{ kg/dm}^3$ and kinematic viscosity $\gamma = 1 \text{ mm}^2/\text{s}$.

**FBDLM SERIES
OPERATING CHARACTERISTICS AT 2850 rpm 50 Hz**

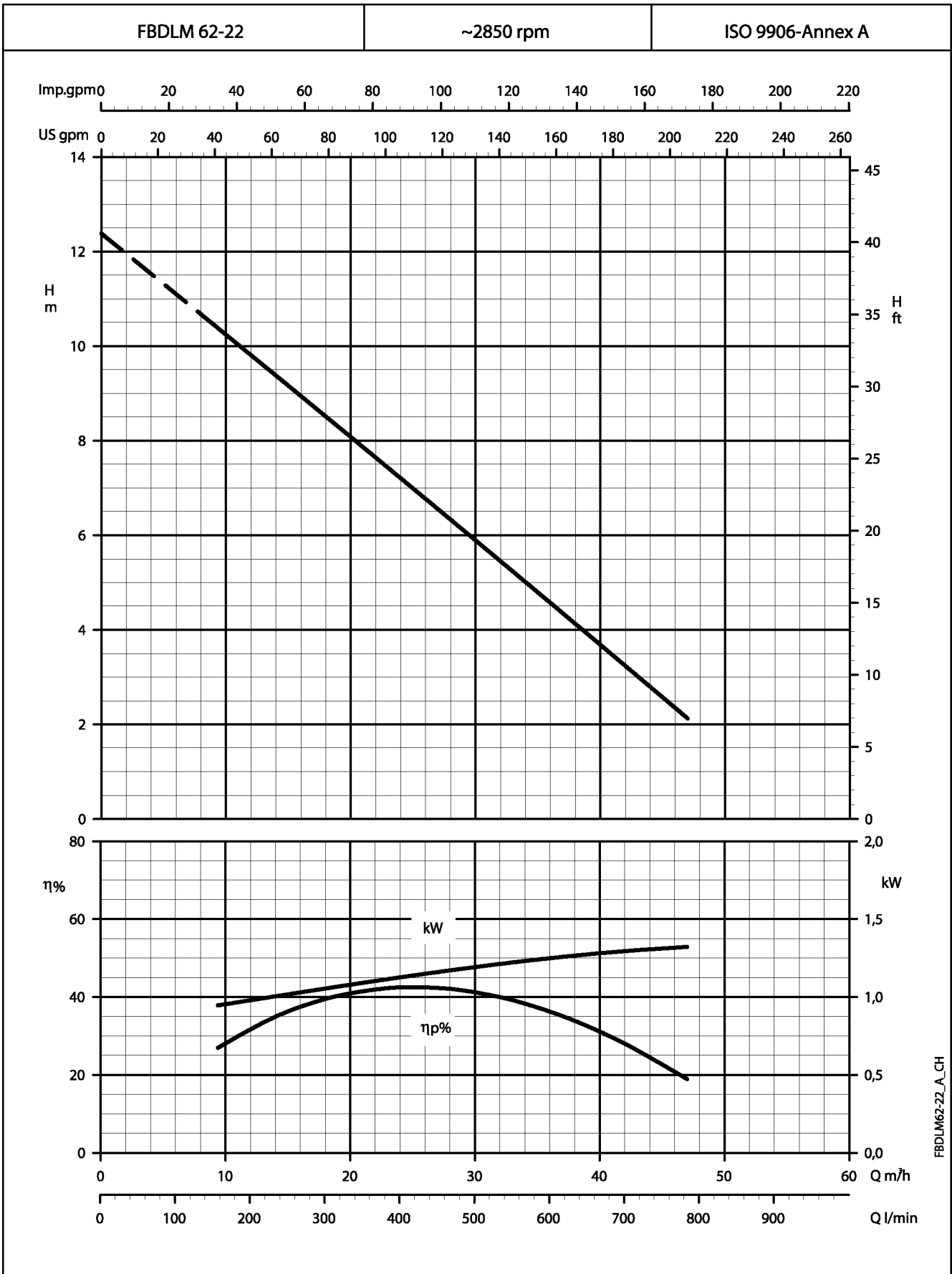

These performances are valid for liquids with density $\rho = 1.0 \text{ kg/dm}^3$ and kinematic viscosity $\nu = 1 \text{ mm}^2/\text{s}$.

**FBDLVM SERIES
OPERATING CHARACTERISTICS AT 2850 rpm 50 Hz**

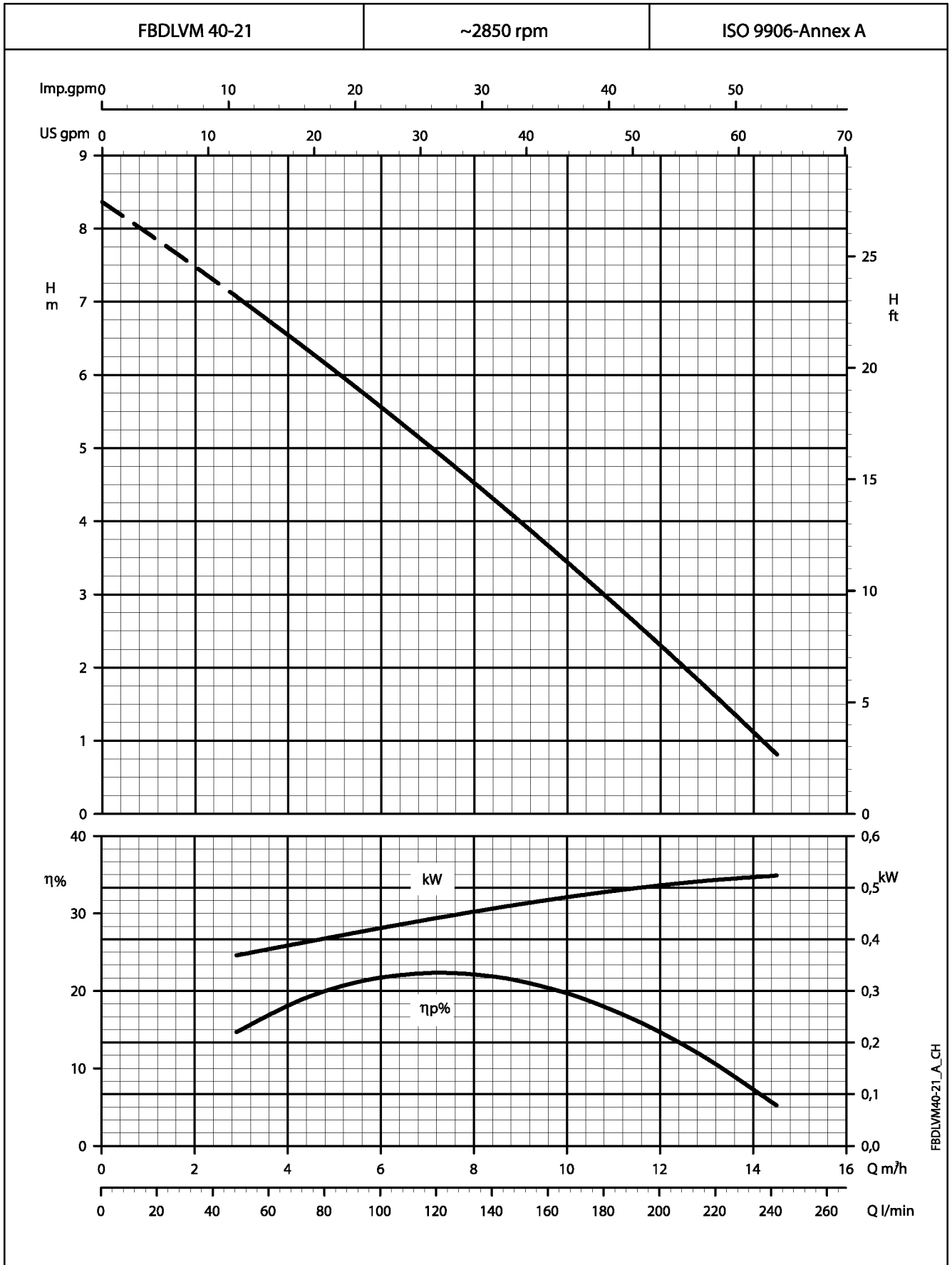

These performances are valid for liquids with density $\rho = 1.0 \text{ kg/dm}^3$ and kinematic viscosity $\gamma = 1 \text{ mm}^2/\text{s}$.

**FBDL SERIES
OPERATING CHARACTERISTICS AT 2850 rpm 50 Hz**

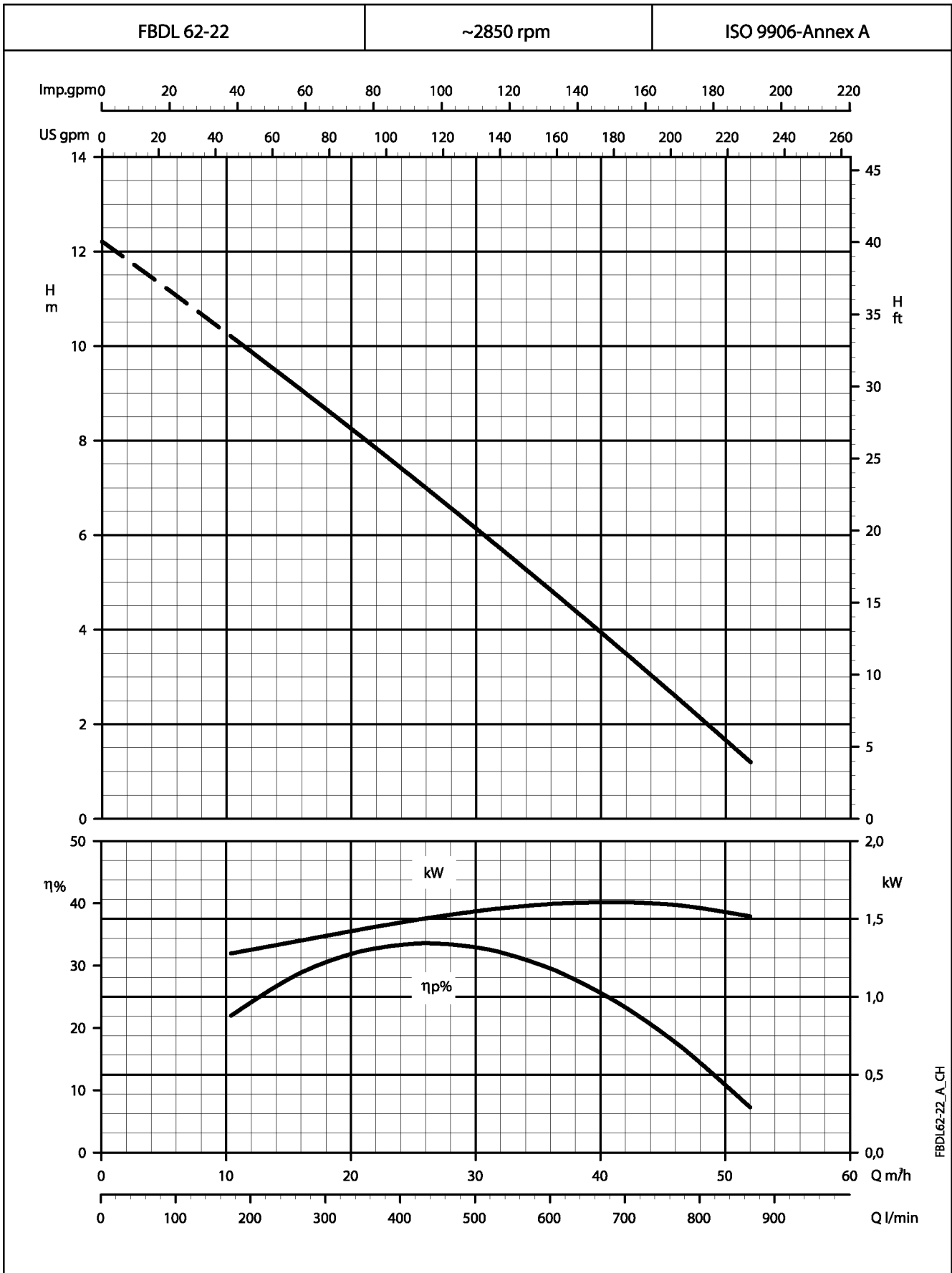

These performances are valid for liquids with density $\rho = 1.0 \text{ kg/dm}^3$ and kinematic viscosity $\gamma = 1 \text{ mm}^2/\text{s}$.

**FBDL SERIES
OPERATING CHARACTERISTICS AT 2850 rpm 50 Hz**

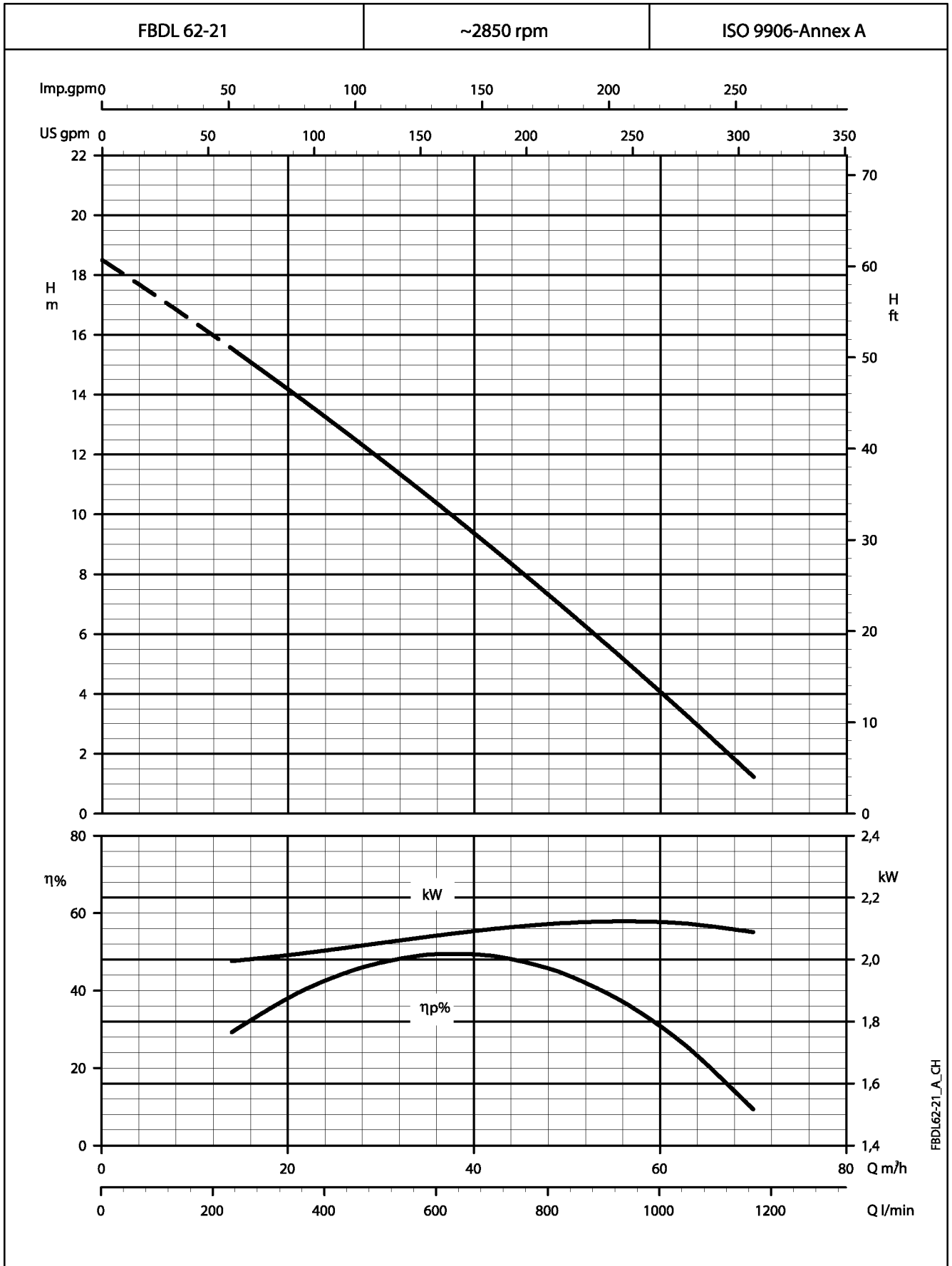

These performances are valid for liquids with density $\rho = 1.0 \text{ kg/dm}^3$ and kinematic viscosity $\gamma = 1 \text{ mm}^2/\text{s}$.

**FBDL SERIES
OPERATING CHARACTERISTICS AT 2850 rpm 50 Hz**

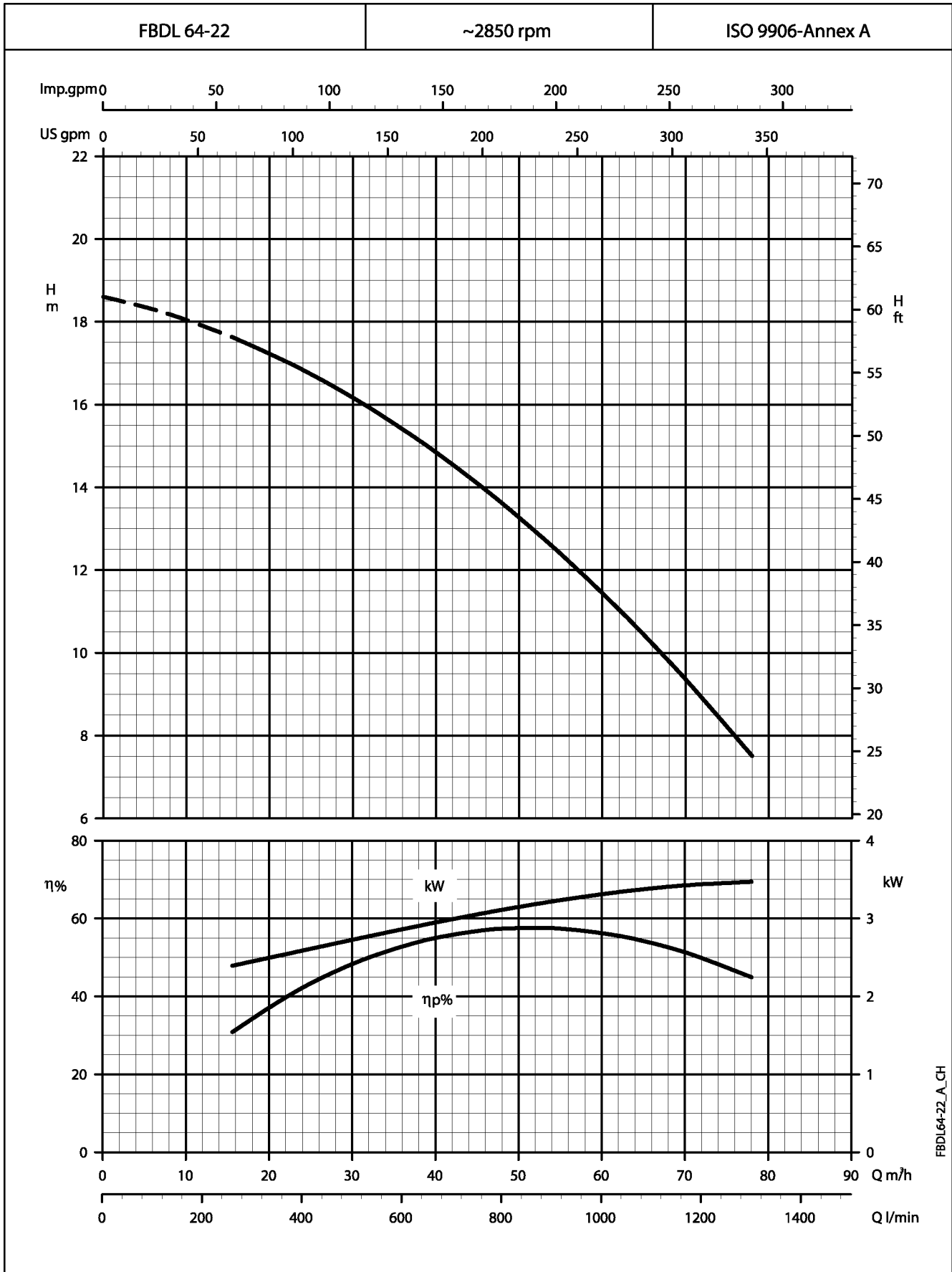

These performances are valid for liquids with density $\rho = 1.0 \text{ kg/dm}^3$ and kinematic viscosity $\gamma = 1 \text{ mm}^2/\text{s}$.

**FBDL SERIES
OPERATING CHARACTERISTICS AT 2850 rpm 50 Hz**

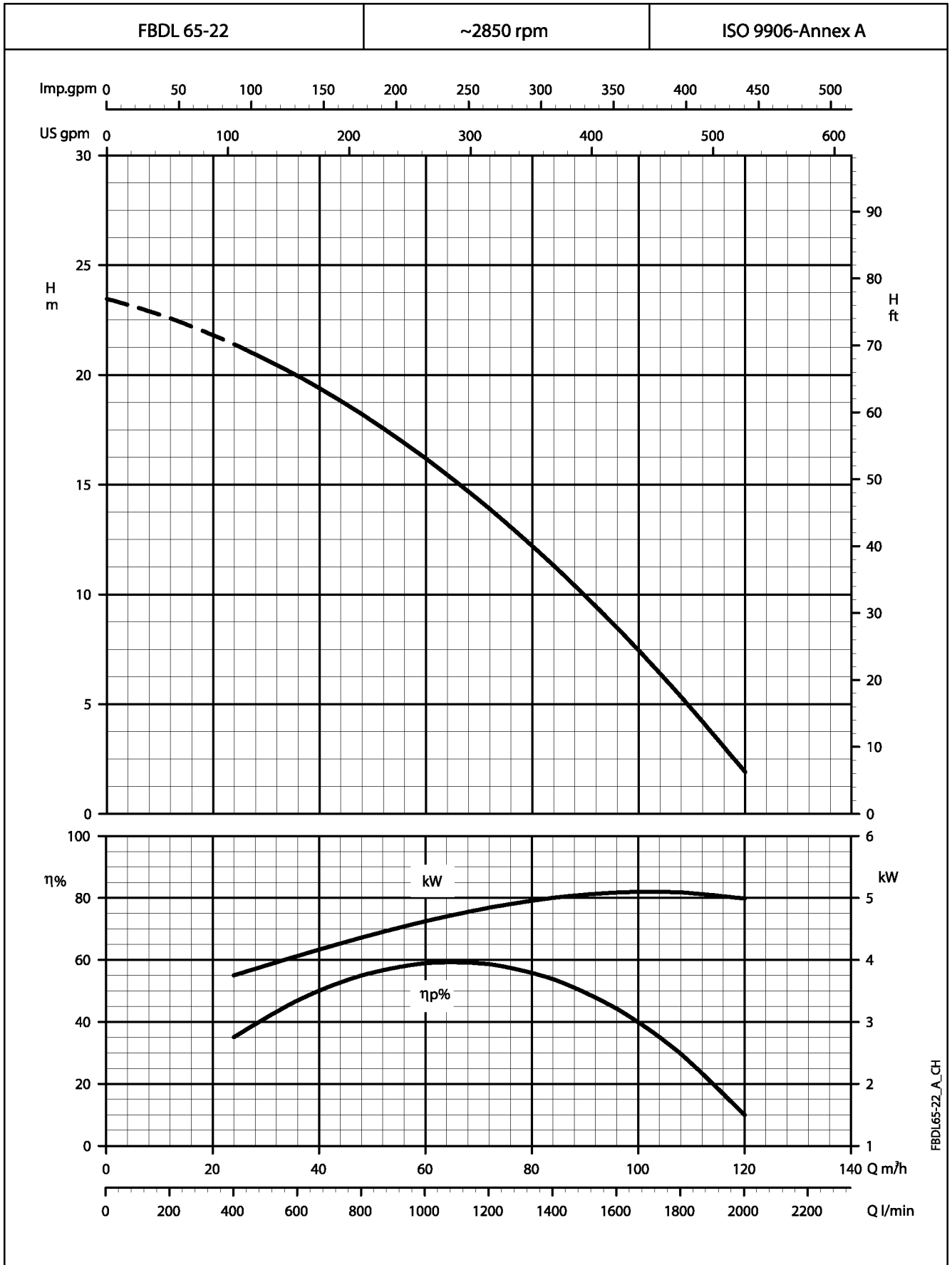

These performances are valid for liquids with density $\rho = 1.0 \text{ kg/dm}^3$ and kinematic viscosity $\gamma = 1 \text{ mm}^2/\text{s}$.

**FBDL SERIES
OPERATING CHARACTERISTICS AT 2850 rpm 50 Hz**

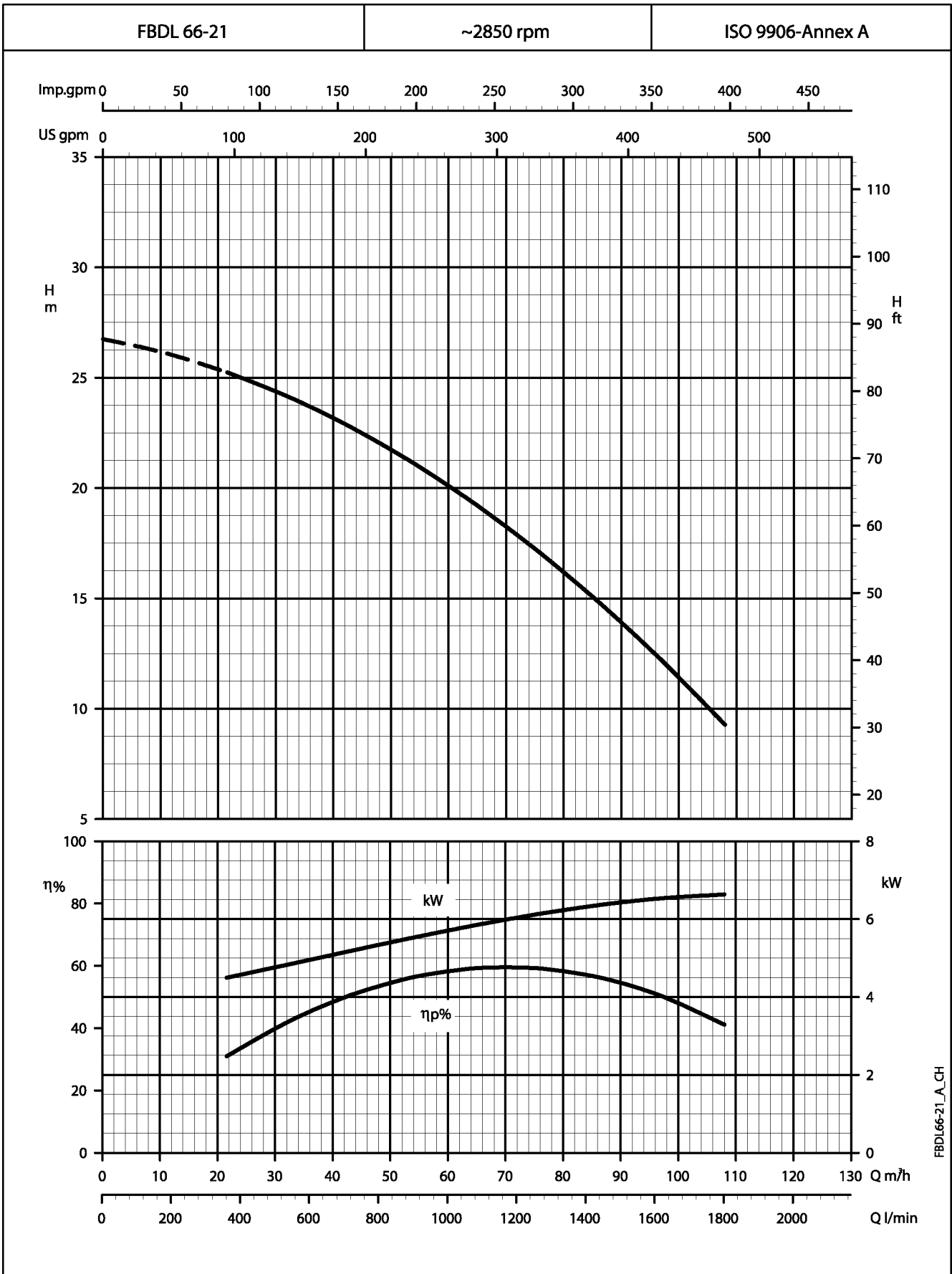

These performances are valid for liquids with density $\rho = 1.0 \text{ kg/dm}^3$ and kinematic viscosity $\gamma = 1 \text{ mm}^2/\text{s}$.

**FBDLV SERIES
OPERATING CHARACTERISTICS AT 2850 rpm 50 Hz**

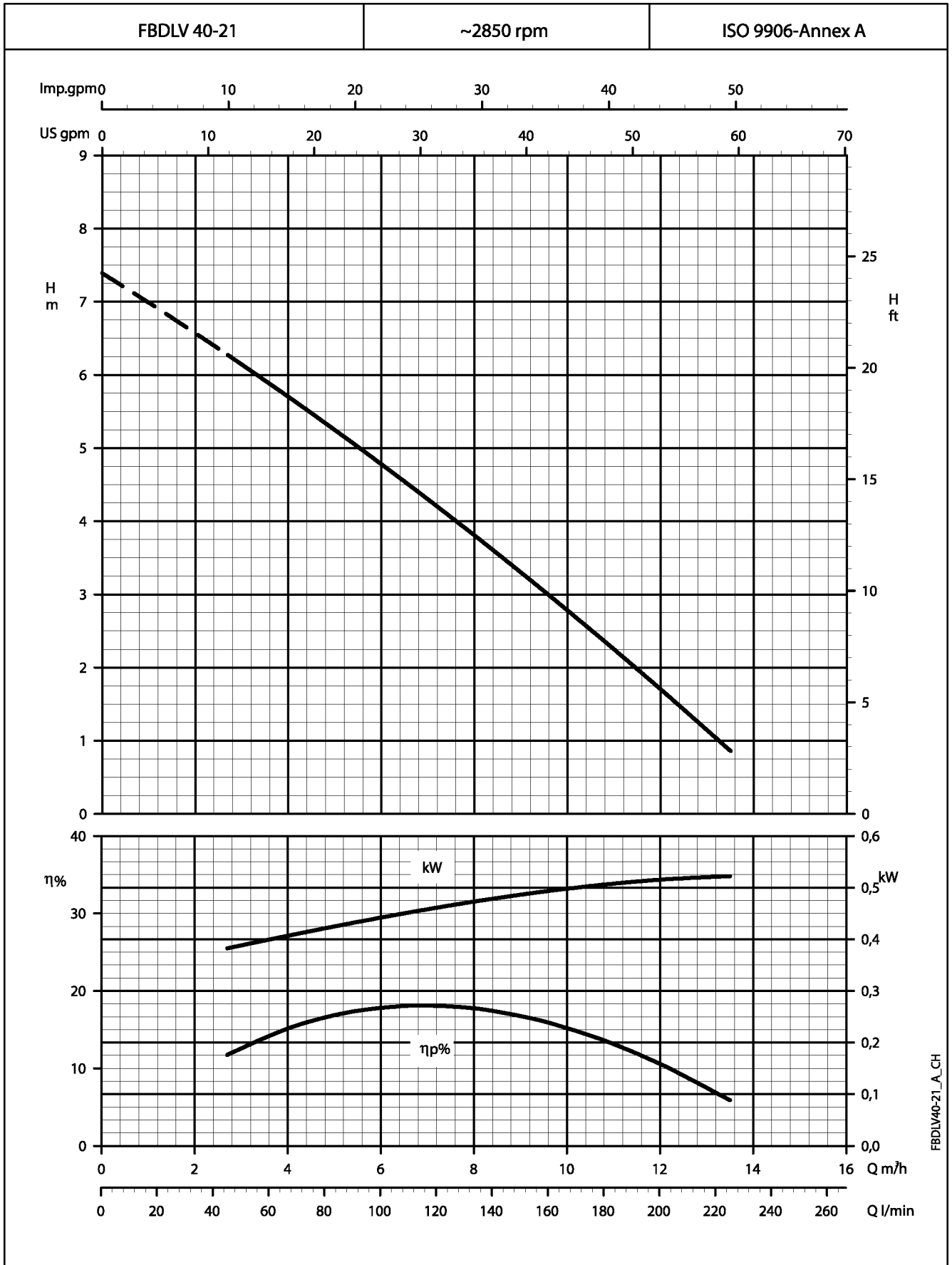

These performances are valid for liquids with density $\rho = 1.0 \text{ kg/dm}^3$ and kinematic viscosity $\gamma = 1 \text{ mm}^2/\text{s}$.

DIMENSIONS AND WEIGHTS, FXDL 70 SERIES

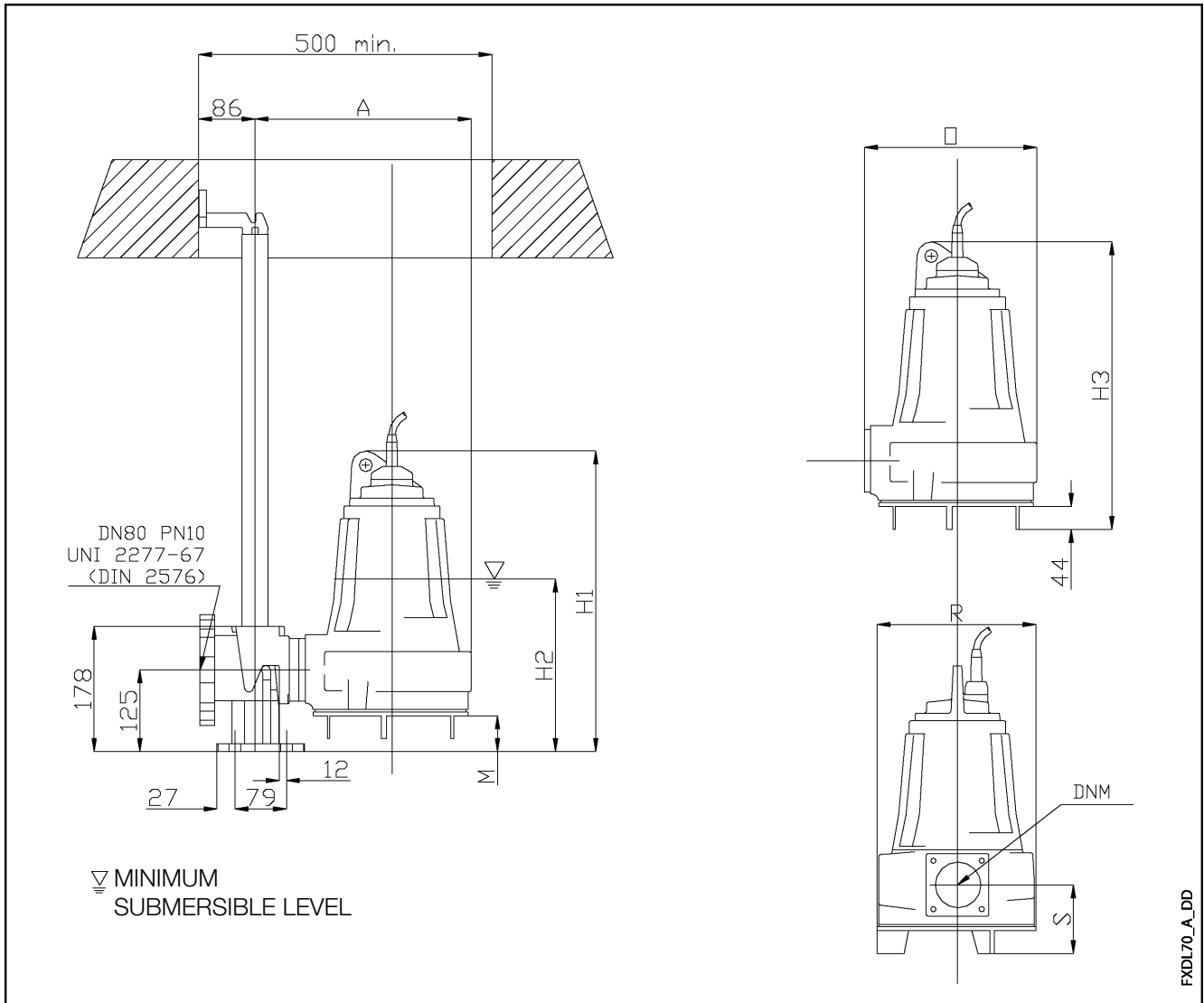

PUMP TYPE	DIMENSIONS (mm)									DNM mm	WEIGHT kg
	A	M	O	R	S	H1	H2	H3			
FXDL 62-22	332	55	279	243	105	460	265	440	70	40	
FXDL 62-21	400	44	348	269	125	472	340	472	70	51	
FXDL 64-22	400	44	348	269	125	472	340	472	70	51	
FXDL 65-22	400	44	348	269	125	570	331	570	70	70	
FXDL 66-21	400	44	348	269	125	570	331	570	70	70	

FXDL70_A_TD

DIMENSIONS AND WEIGHTS, FXDL Rp 1 1/2, Rp 2 SERIES

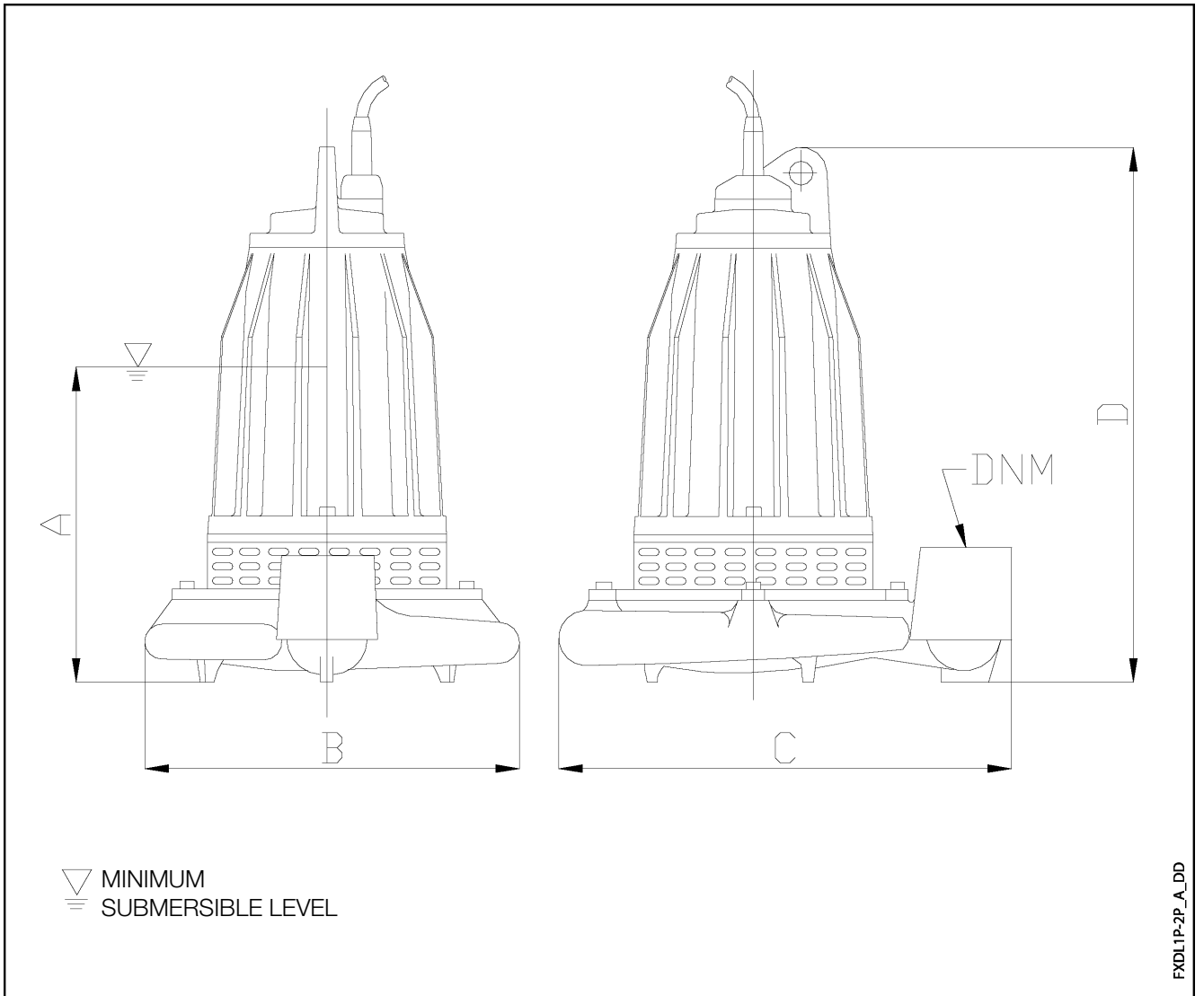

FXDL1P-2P_A_DD

PUMP TYPE	DIMENSIONS (mm)				DNM	WEIGHT kg
	A	B	C	D		
FXDLV 41-21	249	212	240	422	Rp 1 1/2	30
FXDL 41-21	255	212	240	422	Rp 1 1/2	30
FXDL 53-22	264	279	345	440	Rp 2	45
FXDL 56-23	303	290	350	543	Rp 2	92
FXDL 56-22	303	290	350	543	Rp 2	92
FXDL 56-21	303	290	350	543	Rp 2	92

FXDL1P-2P_B_TD

DIMENSIONS AND WEIGHTS, FBDL 70 SERIES

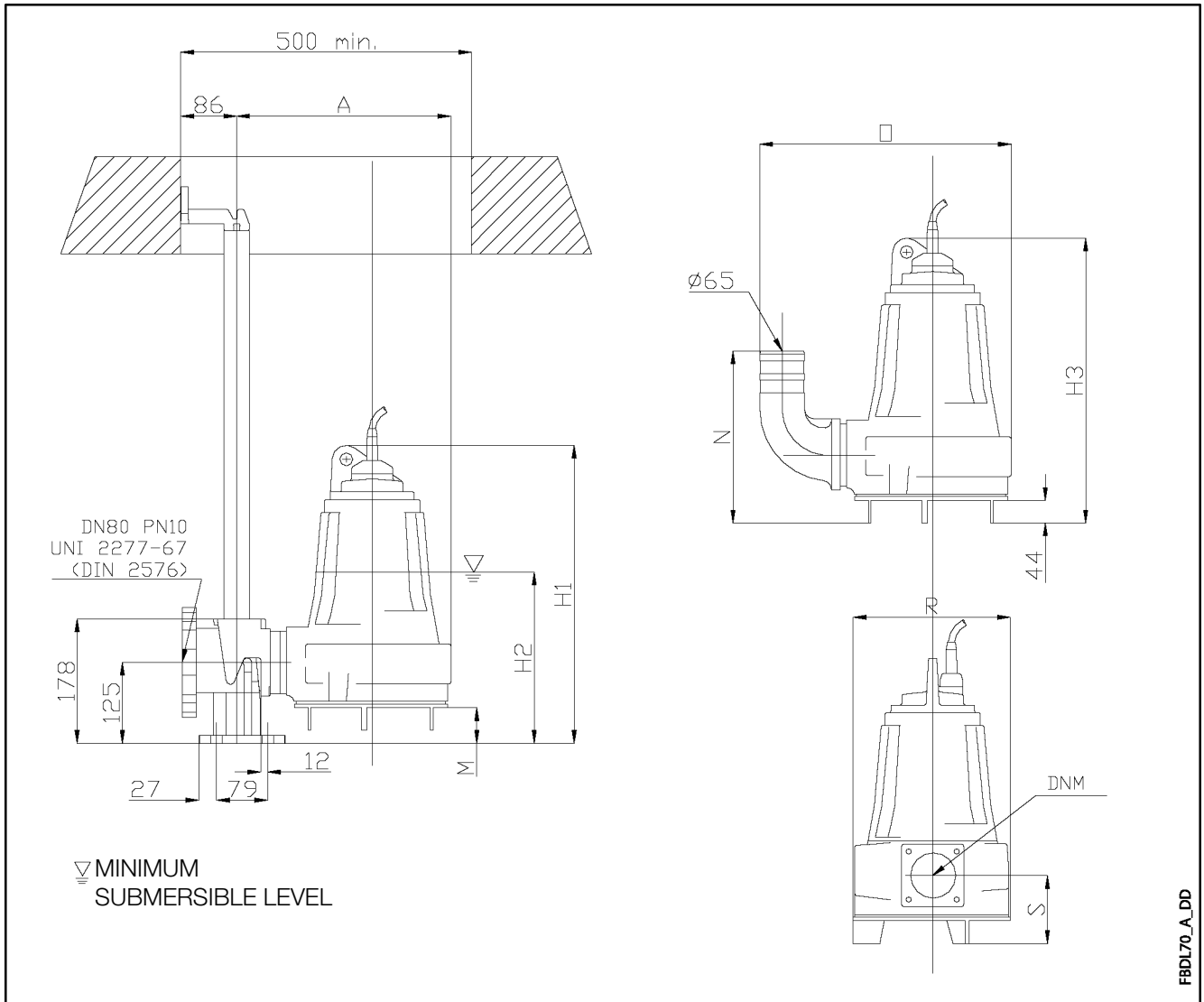

PUMP TYPE	DIMENSIONS (mm)									DNM	WEIGHT kg
	A	M	N	O	R	S	H1	H2	H3		
FBDLM 62-22	332	64	265	388	243	105	460	265	440	70	39
FBDL 62-22	332	64	265	388	243	105	460	265	440	70	39
FBDL 62-21	400	44	285	467	269	125	494	340	494	70	55
FBDL 64-22	400	44	285	467	269	125	494	340	494	70	55
FBDL 65-22	400	44	257	448	242	125	570	331	570	70	79
FBDL 66-21	400	44	257	448	242	125	570	331	570	70	79

FBDL70_A_TD

DIMENSIONS AND WEIGHTS, FBDL Rp 1" 1/4 SERIES

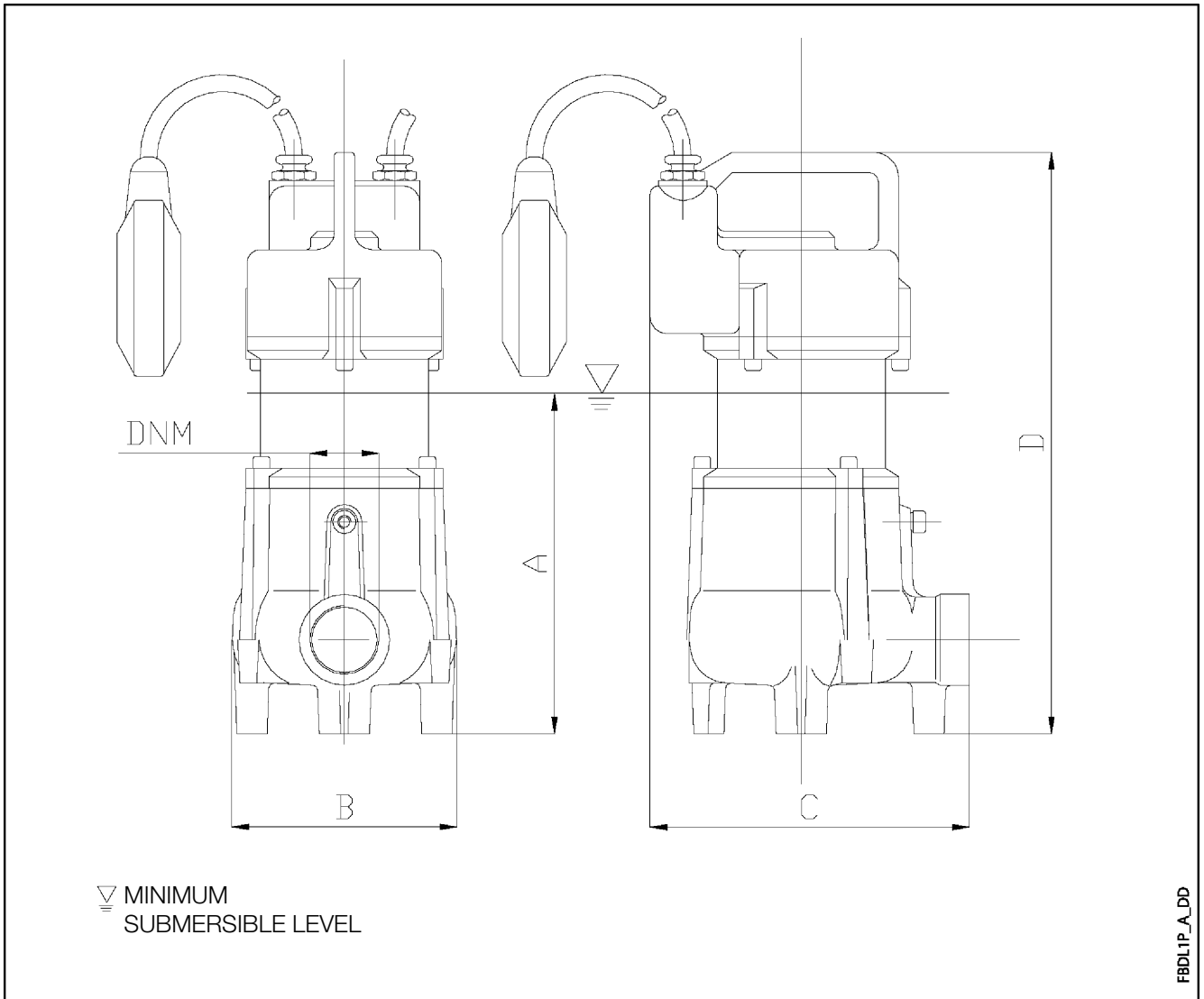

PUMP TYPE	DIMENSIONS (mm)				DNM	WEIGHT kg
	A	B	C	D		
FBDLVM 40-21	203	134	190	346	Rp 1 1/4	16
FBDLV 40-21	203	134	190	346	Rp 1 1/4	16

FBDL1P_B_TD

**PUMP SECTION
FXDL-FBDL SERIES**

FXDL-FBDL

Shafts: in contact with liquid made of AISI 316L stainless steel.

Oil chamber: the oil lubricates and cools the seals and emulsifies any water leaks. The pump is equipped with two mechanical seals for perfect insulation between the electric motor and the pumped liquid. Upper seal: ceramic/graphite. Lower seal: silicon carbide/silicon carbide.

Motor: three-phase asynchronous 2 poles, insulation class F (155°C) for the FBDL series, and H (170°C) for the FXDL series. Dry, cooled by the surrounding liquid.

The radial bearings are sized for minimum 10,000 hours of operation.

Impeller.

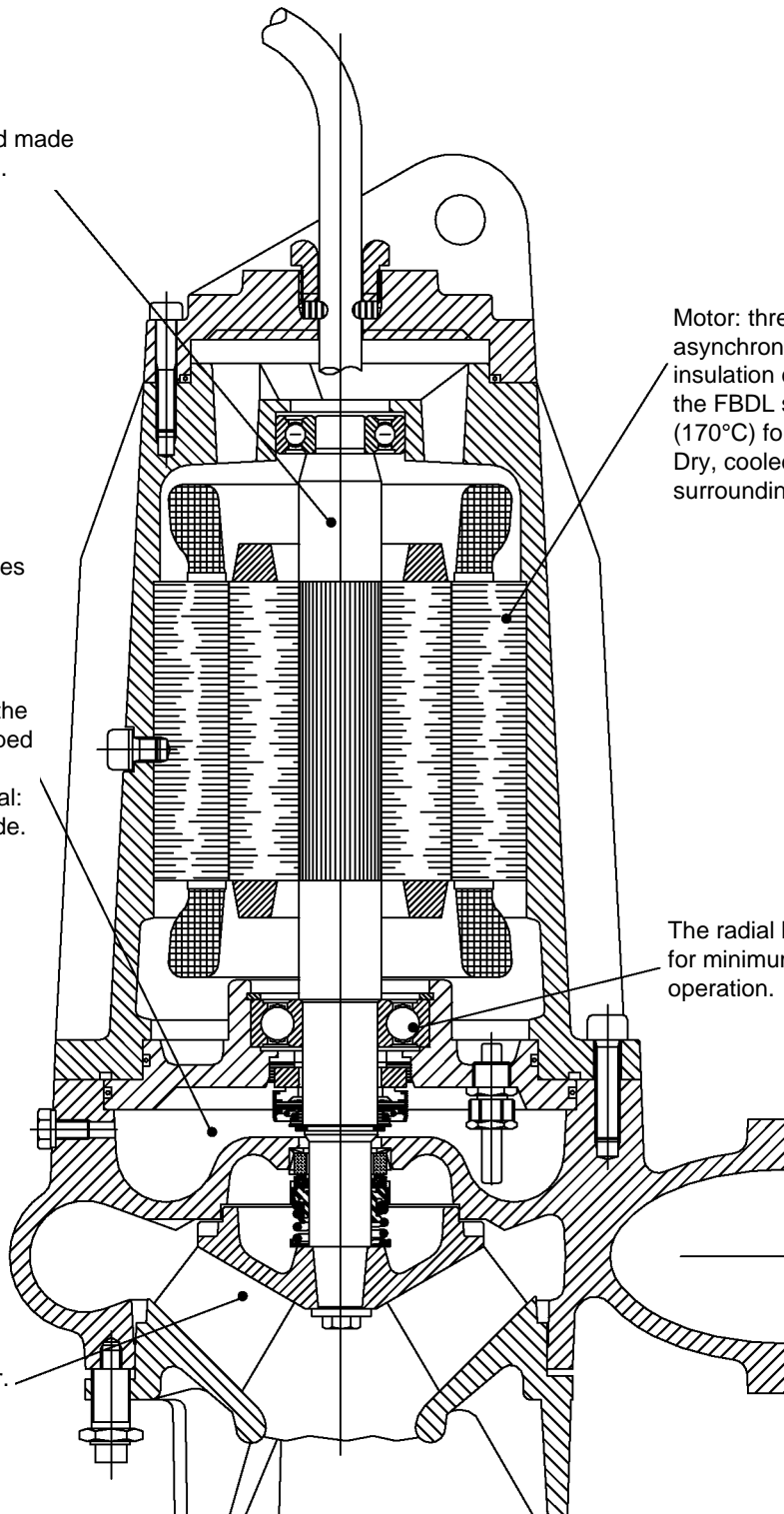

ACCESSORIES

Electric control and protection panels **158**

Installation accessories **167**

Level control and float **175**

Ball check valve **175**

TECHNICAL APPENDIX

Flow resistance **176**

Electric panel for drainage pumps

QDRM SERIES single-phase QDR SERIES three-phase



APPLICATIONS

- Protection and control of a single- or three-phase drainage pump.

SPECIFICATIONS

- Automatic control through electromechanical floats.
- Supply voltage: 1 x 230 V \pm 10 % (single-phase) 3 x 400 V \pm 10% (three-phase).
- Frequency: 50/60 Hz.
- Power: 0.25 to 2.2 kW for single-phase version.
- Power: 0.37 to 9.2 KW for three-phase version.
- Direct motor start.
- Protection class: IP 54.
- Ambient temperature: -5 to +40 °C (according to EN 60439-1).
- Maximum relative humidity: 50% at +40°C, provided that no condensation occurs (according to EN 60439-1).
- Wall mounted.
- Metal enclosure.
- Power, thermal overload, high level indicator lights.

OPTIONAL ACCESSORIES

- Audible or visual signalling device, 12 Vdc 0.5 A max (connection terminal inside the electric panel) for high-level alarm.
 - 109890740 VR1 single-phase module (for QDRM) for overvoltage protection (lightning protector).
 - 109890760 VR3 three-phase module (for QDR) for overvoltage protection (lightning protector).

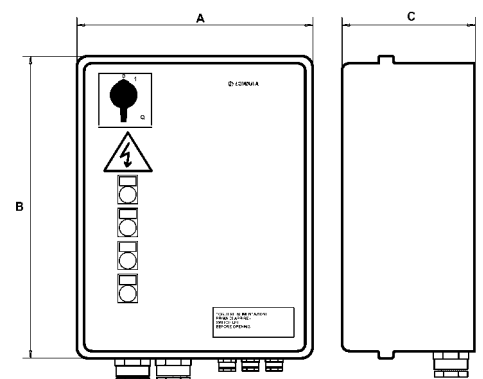

ELECTRICAL DATA

PANEL TYPE	RATED POWER		APPLICATION RANGE A	DIMENSIONS A x B x C	WEIGHT WITH PACKING kg	COMPATIBLE ELECTRIC PUMPS DRAINAGE
	kw	HP				
QDRM/02	0,25	0,33	1,4-2,3	235x265x150	6,3	All the pumps in this range that are equipped with an incorporated capacitor or with one that is integrated in an external container can be supplied without pre-assembled float.
QDRM/03	0,37	0,5	2,0-3,3			
QDRM/05	0,55	0,75	3,0-5,0			
QDRM/07	0,75	1	4,5-7,5			
QDRM/11	1,1	1,5	6,0-10,0			
QDRM/22	2,2	3	9,0-15,0			

PANEL TYPE	RATED POWER		APPLICATION RANGE A	DIMENSIONS A x B x C	WEIGHT WITH PACKING kg	COMPATIBLE ELECTRIC PUMPS DRAINAGE
	kw	HP				
QDR/03	0,37	0,5	0,9-1,5	235x265x150	6,3	DOC DIWA DN DOMO DL FDL* FXDL* FBDL*
QDR/05	0,55	0,75	1,4-2,3			
QDR/11	1,1	1,5	2,0-3,3			
QDR/15	1,5	2	3,0-5,0			
QDR/22	2,2	3	4,5-7,5			
QDR/30	3	4	6,0-10,0			
QDR/40	4	5,5	9,0-12,0			
QDR/55	5,5	7,5	9,0-15,0			
QDR/92	9,2	12,5	14,0-23,0			

Line protection to be provided by user.

* Electric pump without thermal stator protection or water sensor in oil chamber.

For proper selection, make sure that the ampere input of the electric motor falls within the application range shown in the table.

Electric panel for drainage pumps

9QDRM2 SERIES single-phase 9QDR2 SERIES three-phase



APPLICATIONS

- Protection and control of two single- or three-phase drainage pumps.

SPECIFICATIONS

- Automatic control through electromechanical floats.
- Supply voltage: 1 x 230 V \pm 10 % (single-phase) 3 x 400 V \pm 10% (three-phase).
- Frequency: 50/60 Hz.
- Power: 0.25 to 2.2 kW for single-phase version.
- Power: 0.37 to 9.2 KW for three-phase version.
- Direct motor start.
- Protection class: IP 54.
- Ambient temperature: -5 to +40 °C (according to EN 60439-1).
- Maximum relative humidity: 50% at +40°C, provided that no condensation occurs (according to EN 60439-1).
- Wall mounted.
- Metal enclosure.
- Electronic board with power, thermal overload, high level alarm, pump start/stop indicator LEDs.

OPTIONAL ACCESSORIES

- Audible or visual signalling device, 12 Vdc 0.3 A max (two connection terminals inside the electric panel) for high-level alarm.
 - 109890740 VR1 single-phase module (for 9QDRM2) for overvoltage protection (lightning protector).
 - 109890760 VR3 three-phase module (for 9QDR2) for overvoltage protection (lightning protector).
 - 109391130 signal relay board kit (power, auto/man, start/stop, thermal overload, high level).

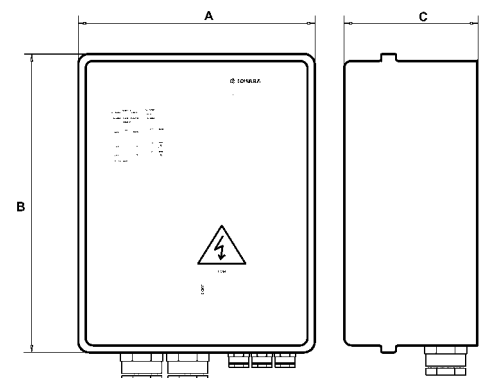

ELECTRICAL DATA

PANEL TYPE	RATED POWER		APPLICATION RANGE A	DIMENSIONS A x B x C	WEIGHT WITH PACKING kg	COMPATIBLE ELECTRIC PUMPS DRAINAGE
	kw	HP				
9QDRM2/02	0,25	0,33	1,0-1,6	260x380x150	9,4	All the pumps in this range that are equipped with an incorporated capacitor or with one that is integrated in an external container can be supplied without pre-assembled float.
9QDRM2/03	0,37	0,5	1,6-2,5			
9QDRM2/05	0,55	0,75	2,5-4,0			
9QDRM2/07	0,75	1	4,0-6,5			
9QDRM2/11	1,1	1,5	6,3-10,0			
9QDRM2/22	2,2	3	9,0-14,0			

PANEL TYPE	RATED POWER		APPLICATION RANGE A	DIMENSIONS A x B x C	WEIGHT WITH PACKING kg	COMPATIBLE ELECTRIC PUMPS DRAINAGE
	kw	HP				
9QDR2/03	0,37	0,5	0,63-1,0	260x380x150	9,4	DOC DIWA DN DOMO DL FDL* FXDL* FBDL*
9QDR2/05	0,55	0,75	1,0-1,6			
9QDR2/11	1,1	1,5	1,6-2,5			
9QDR2/15	1,5	2	2,5-4,0			
9QDR2/22	2,2	3	4,0-6,5			
9QDR2/30	3	4	6,3-10,0			
9QDR2/40	4	5,5	9,0-14,0			
9QDR2/55	5,5	7,5	13,0-18,0			
9QDR2/92	9,2	12,5	17,0-23,0	300x400x180		

Line protection to be provided by user.

* Electric pump without thermal stator protection or water sensor in oil chamber.

For proper selection, make sure that the ampere input of the electric motor falls within the application range shown in the table.

Electric panel for drainage pumps

9QDR2/FG SERIES three-phase

9QYR2/FG SERIES three-phase



APPLICATIONS

- Protection and control of two three-phase drainage pumps.

SPECIFICATIONS

- Automatic control through electromechanical floats.
- Supply voltage: $3 \times 400 \text{ V} \pm 10\%$ (three-phase).
- Frequency: 50/60 Hz.
- Power: 0.8 to 11.2 kW for the three-phase version.
- Direct motor start up to 7.5 kW, star-delta start from 7.5 kW and up.
- Protection class: IP 54.
- Ambient temperature: -5 to $+40^\circ\text{C}$ (according to EN 60439-1).
- Maximum relative humidity: 50% at $+40^\circ\text{C}$, provided that no condensation occurs (according to EN 60439-1).
- Wall mounted.
- Metal enclosure.
- Electronic board with power, thermal overload, high level alarm, pump start/stop indicator LEDs.
- Designed to accommodate thermal stator protector and a water sensor in the oil chamber.

OPTIONAL ACCESSORIES

- Audible or visual signalling device, 12 Vdc 0.3 A max (connection terminal inside the electric panel) for high-level alarm.
 - 109890760 VR3 three-phase module (for 9QDR2) for overvoltage protection (lightning protector).
 - 109391130 signal relay board kit (power, auto/man, start/stop, thermal overload, high level).

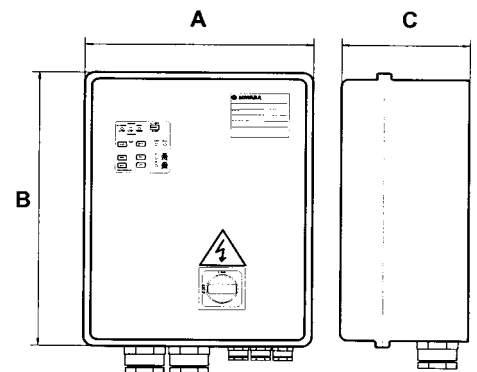

PANEL TYPE	RATED POWER		APPLICATION RANGE A	DIMENSIONS A x B x C	WEIGHT WITH PACKING kg	COMPATIBLE ELECTRIC PUMPS DRAINAGE
	kW	HP				
9QDR2/08-10/FG	0,8-1	0,9-1,3	1,6-2,5	260x380x150	10	FDL* FXDL* FBDL*
9QDR2/1-22/FG	1,5-2,2	2-3	2,5-4			
9QDR2/24-35/FG	2,4-3,5	3,2-4,7	4-6,5			
9QDR2/38-52/FG	3,8-5,2	5,1-7	6,3-10			
9QDR2/54-68/FG	5,4-6,8	7,3-9,2	9-14			
9QDR2/96/FG	9,6	13	17-23			
9QDR2/112/FG	11,2	15,2	20-25			
9QYR2/96-112/FG	9,6-11,2	13-15,2	16-25			
9QYR2/155/FG	15,5	21	24-35			
9QYR2/235-247/FG	23,5-24,7	32-33,6	35-50			
9QYR2/296-306/FG	29,6-30,6	40-41,5	48-62			

Line protection to be provided by user.

* Electric pump without thermal stator protection or water sensor in oil chamber.

For proper selection, make sure that the ampere input of the electric motor falls within the application range shown in the table.

Electric panel for drainage pumps

QDR/FG SERIES three-phase QYR/FG SERIES three-phase



APPLICATIONS

- Protection and control of a three-phase drainage pump.

SPECIFICATIONS

- Automatic control through electromechanical floats.
- Supply voltage: 3 x 400 V ± 10% (three-phase).
- Frequency: 50/60 Hz.
- Power: 0.8 to 6.8 kW for the three-phase version.
- Direct motor start up to 7.5 kW, star-delta start from 7.5 kW and up.
- Protection class: IP 54.
- Ambient temperature: -5 to +40 °C (according to EN 60439-1).
- Maximum relative humidity: 50% at +40°C, provided that no condensation occurs (according to EN 60439-1).
- Wall mounted.
- Metal enclosure.
- Power, thermal overload, high level indicator lights.
- Designed to accommodate thermal stator protector and water sensor in the oil chamber.

OPTIONAL ACCESSORIES

- Audible or visual signalling device, 12 Vdc 0.3 A max (connection terminal inside the electric panel) for high-level alarm.
 - 109890760 VR3 three-phase module (for QDR) for overvoltage protection (lightning protector).

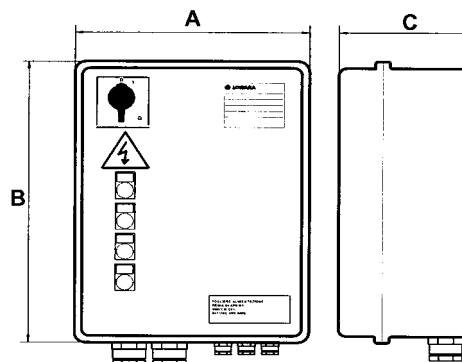

PANEL TYPE	RATED POWER		APPLICATION RANGE A	DIMENSIONS A x B x C	WEIGHT WITH PACKING kg	COMPATIBLE ELECTRIC PUMPS DRAINAGE
	kW	HP				
QDR/08-10/FG	0,8-1	0,9-1,3	1,6-2,5	235x265x150	6,5	FDL* FBDL* FXDL*
QDR/15-22/FG	1,5-2,2	2-3	2,5-4			
QDR/24-35/FG	2,4-3,5	3,2-4,7	4-6,5			
QDR/38-52/FG	3,8-5,2	5,1-7	6,3-10			
QDR/54-68/FG	5,4-6,8	7,3-9,2	9-14			
QYR/96-112/FG	9,6-11,2	13-15,2	16-25			
QYR/155/FG	15,5	21	24-35			
QYR/235-247/FG	23,5-24,7	32-33,6	35-50			
QYR/296-306/FG	29,6-30,6	40-41,5	48-62			

Line protection to be provided by user.

* Electric pump without thermal stator protection or water sensor in oil chamber.

For proper selection, make sure that the ampere input of the electric motor falls within the application range shown in the table.

ELECTRIC CONTROL AND PROTECTION PANELS, FDL SERIES

Lowara supplies panels for the complete control and command of the FDL series electric pumps, designed to cover all the most common applications. Panels for special applications can be supplied upon request. The standard configurations allow floats to be connected to the panels.

PUMP TYPE THREE-PHASE	1 PUMP		2 PUMPS	
	220-240 V	380-415 V	220-240 V	380-415 V
FDL 62-26	QDR/15-20/230/FG	QDR11	on request	9QDR2/11
FDL 62-25	QDR/15-20/230/FG	QDR11	on request	9QDR2/15
FDL 62-24	QDR/15-20/230/FG	QDR11	on request	9QDR2/15
FDL 62-23	QDR/15-20/230/FG	QDR11	on request	9QDR2/15
FDL 62-21	QDR/22-28/230/FG	QDR15	on request	9QDR2/15
FDL 815-23	on request	QYR/96-112/FG	on request	9QYR2/96-112/FG
FDL 815-22	on request	QYR/155/FG	on request	9QYR2/155/FG
FDL 815-21	on request	QYR/155/FG	on request	9QYR2/155/FG
FDL 81-42	on request	QDR/11	on request	9QDR2/15
FDL 82-41N	on request	QDR/22	on request	9QDR2/22
FDL 83-41	on request	QDR/22	on request	9QDR2/22
FDL 104-42	QDR/43-52/230/FG	QDR/38-52/FG	9QDR2/43-52/230/FG	9QDR2/38-52/FG
FDL 104-41	QDR/43-52/230/FG	QDR/38-52/FG	9QDR2/43-52/230/FG	9QDR2/38-52/FG
FDL 106-41	QDR/66/230/FG	QDR/54-68/FG	9QDR2/66/230/FG	9QDR2/54-68/FG
FDL 107-41	QDR/43-52/230/FG	QDR/54-68/FG	9QDR2/43-52/230/FG	9QDR2/54-68/FG
FDL 109-42	on request	QYR/96-112/FG	on request	9QYR2/96-112/FG
FDL 109-41	on request	QYR/96-112/FG	on request	9QYR2/96-112/FG
FDL 152-43	on request	QYR/155/FG	on request	9QYR2/155/FG
FDL 152-42	on request	QYR/155/FG	on request	9QYR2/155/FG
FDL 152-41	on request	QYR/235-247/FG	on request	9QYR2/235-247/FG
FDL 64-22	QDR/30-38/230/FG	QDR22	on request	9QDR2/22
FDL 85-22	QDR/43-52/230/FG	QDR/38-52/FG	9QDR2/43-52/230/FG	9QDR2/38-52/FG
FDL 86-21	QDR/66/230/FG	QDR/54-68/FG	9QDR2/66/230/FG	9QDR2/54-68/FG
FDL 118-24	on request	QYR/96-112/FG	on request	9QYR2/96-112/FG
FDL 118-23	on request	QYR/155/FG	on request	9QYR2/155/FG
FDL 118-22	on request	QYR/155/FG	on request	9QYR2/155/FG
FDL 118-21	on request	QYR/155/FG	on request	9QYR2/155/FG
FDL 107-42	QDR/66/230/FG	QDR/54-68/FG	9QDR2/66/230/FG	9QDR2/54-68/FG
FDL 101-41	on request	QYR/96-112/FG	on request	9QYR2/96-112/FG
FDL 153-43	on request	QYR/235-247/FG	on request	9QYR2/235-247/FG
FDL 153-43/1	on request	QYR/235-247/FG	on request	9QYR2/235-247/FG
FDL 153-41/1	on request	QYR/295-306/FG	on request	9QYR2/295-306/FG
FDL 153-42	on request	QYR/295-306/FG	on request	9QYR2/295-306/FG
FDL 153-41	on request	QYR/295-306/FG	on request	9QYR2/295-306/FG
FDL 154-43	on request	QYR/295-306/FG	on request	9QYR2/295-306/FG
FDL 154-42	on request	on request	on request	on request
FDL 154-41	on request	on request	on request	on request
FDL 102-61	QDR/30-38/230/FG	QDR/24-35/FG	9QDR2/30-38/230/FG	9QDR2/24-35/FG
FDL 158-61	on request	QYR/96-112/FG	on request	9QYR2/96-112/FG
FDL 151-62	on request	QYR/96-112/FG	on request	9QYR2/96-112/FG
FDL 151-61	on request	QYR/96-112/FG	on request	9QYR2/96-112/FG
FDL 201-63	on request	QYR/96-112/FG	on request	9QYR2/96-112/FG
FDL 201-62	on request	QYR/96-112/FG	on request	9QYR2/96-112/FG
FDL 201-61	on request	QYR/96-112/FG	on request	9QYR2/96-112/FG
FDL 252-62	on request	QYR/155/FG	on request	9QYR2/155/FG
FDL 253-64	on request	QYR/235-247/FG	on request	9QYR2/235-247/FG
FDL 252-61	on request	QYR/235-247/FG	on request	9QYR2/235-247/FG
FDL 253-63	on request	QYR/235-247/FG	on request	9QYR2/235-247/FG
FDL 253-62	on request	QYR/295-306/FG	on request	9QYR2/295-306/FG
FDL 253-61	on request	on request	on request	on request

FDL_B_TO

ELECTRIC CONTROL AND PROTECTION PANELS, FDLV SERIES

Lowara supplies panels for the complete control and command of the FDLV series electric pumps, designed to cover all the most common applications. Panels for special applications can be supplied upon request. The standard configurations allow floats to be connected to the panels.

PUMP TYPE THREE-PHASE	1 PUMP		2 PUMPS	
	220-240 V	380-415 V	220-240 V	380-415 V
FDLV 62-22	on request	QDR/22	on request	9QDR2/22
FDLV 62-21	on request	QDR/22	on request	9QDR2/22
FDLV 84-22	QDR/30-38/230/FG	QDR/38-52/FG	9QDR2/30-38/230/FG	9QDR2/38-52/FG
FDLV 85-21	on request	QDR/54-68/FG	on request	9QDR2/54-68/FG
FDLV 815-24	on request	QYR/155/FG	on request	9QYR2/155/FG
FDLV 815-23	on request	QYR/155/FG	on request	9QYR2/155/FG
FDLV 815-22	on request	QYR/155/FG	on request	9QYR2/155/FG
FDLV 815-21	on request	QYR/155/FG	on request	9QYR2/155/FG
FDLV 62-45	on request	QDR/11	on request	9QDR2/11
FDLV 62-44	on request	QDR/11	on request	9QDR2/15
FDLV 62-43	on request	QDR/11	on request	9QDR2/15
FDLV 61-42	on request	QDR/11	on request	9QDR2/15
FDLV 61-41	on request	QDR/11	on request	9QDR2/15
FDLV 82-42N	on request	QDR/24-35/FG	on request	9QDR2/24-35/FG
FDLV 82-41N	on request	QDR/22	on request	9QDR2/22
FDLV 83-42N	QDR/30-38/230/FG	QDR/38-52/FG	9QDR2/30-38/230/FG	9QDR2/38-52/FG
FDLV 83-41N	QDR/43-52/230/FG	QDR/38-52/FG	9QDR2/43-52/230/FG	9QDR2/38-52/FG
FDLV 104-41	QDR/43-52/230/FG	QDR/38-52/FG	9QDR2/43-52/230/FG	9QDR2/38-52/FG
FDLV 106-42	QDR/43-52/230/FG	QDR/38-52/FG	9QDR2/43-52/230/FG	9QDR2/38-52/FG
FDLV 106-41	QDR/66/230/FG	QDR/54-68/FG	9QDR2/66/230/FG	9QDR2/54-68/FG
FDLV 152-44	on request	QYR/155/FG	on request	9QYR2/155/FG
FDLV 152-43	on request	QYR/235-247/FG	on request	9QYR2/235-247/FG
FDLV 152-42	on request	QYR/235-247/FG	on request	9QYR2/235-247/FG
FDLV 153-41	on request	QYR/295-306/FG	on request	9QYR2/295-306/FG
FDLV 158-64	QDR/66/230/FG	QDR/54-68/FG	9QDR2/66/230/FG	9QDR2/54-68/FG
FDLV 158-63	on request	on request	on request	on request
FDLV 151-62	on request	QYR/96-112/FG	on request	9QYR2/96-112/FG
FDLV 151-61	on request	QYR/155/FG	on request	9QYR2/155/FG

FDLV_B_TQ

ELECTRIC CONTROL AND PROTECTION PANELS, FDLT SERIES

Lowara supplies panels for the complete control and command of the FDLT series electric pumps, designed to cover all the most common applications. Panels for special applications can be supplied upon request. The standard configurations allow floats to be connected to the panels.

PUMP TYPE THREE-PHASE	1 PUMP		2 PUMPS	
	220-240 V	380-415 V	220-240 V	380-415 V
FDLT 41-23	on request	QDR/11	on request	9QDR2/11
FDLT 41-22	on request	QDR/11	on request	9QDR2/15
FDLT 41-21	on request	QDR/11	on request	9QDR2/15
FDLT 42-22	on request	QDR/11	on request	9QDR2/15
FDLT 42-21	on request	QDR/15	on request	9QDR2/15
FDLT 43-22	on request	QDR/15	on request	9QDR2/22
FDLT 43-21	on request	QDR/22	on request	9QDR2/22
FDLT 44-22	QDR/30-38/230/FG	QDR/38-52/FG	9QDR2/30-38/230/FG	9QDR2/38-52/FG
FDLT 44-21	QDR/30-38/230/FG	QDR/38-52/FG	9QDR2/30-38/230/FG	9QDR2/38-52/FG
FDLT 45-21	QDR/43-52/230/FG	QDR/38-52/FG	9QDR2/43-52/230/FG	9QDR2/38-52/FG

FDLT_B_TQ

PUMP TYPE SINGLE-PHASE	1 PUMP 220-240 V
FDLMT 41-23	standard
FDLMT 41-22	standard
FDLMT 41-21	standard
FDLMT 42-22	standard
FDLMT 42-21	standard

2 PUMPS 220-240 V
on request
on request
on request
on request

ELECTRIC CONTROL AND PROTECTION PANELS, FXDL SERIES

Lowara supplies panels for the complete control and command of the FXDL series electric pumps, designed to cover all the most common applications. Panels for special applications can be supplied upon request. The standard configurations allow floats to be connected to the panels.

PUMP TYPE THREE-PHASE	1 PUMP		2 PUMPS	
	220-240 V	380-415 V	220-240 V	380-415 V
FXDL 41-21	on request	QDR/05	on request	9QDR2/11
FXDL 53-22	on request	QDR/22	on request	9QDR2/22
FXDL 56-23	QDR/43-52/230/FG	QDR/54-68/FG	9QDR2/43-52/230/FG	9QDR2/54-68/FG
FXDL 56-22	QDR/66/230/FG	QDR/54-68/FG	9QDR2/66/230/FG	9QDR2/54-68/FG
FXDL 56-21	QDR/66/230/FG	QDR/54-68/FG	9QDR2/66/230/FG	9QDR2/54-68/FG
FXDL 62-22	on request	QDR/11	on request	9QDR2/15
FXDL 62-21	on request	QDR/15	on request	9QDR2/15
FXDL 64-22	on request	QDR/22	on request	9QDR2/30
FXDL 65-22	QDR/43-52/230/FG	QDR/38-52/FG	9QDR2/43-52/230/FG	9QDR2/38-52/FG
FXDL 66-21	QDR/66/230/FG	QDR/54-68/FG	9QDR2/66/230/FG	9QDR2/54-68/FG
FXDLV 41-21	on request	QDR/05	on request	9QDR2/11

FXDL_B_TQ

ELECTRIC CONTROL AND PROTECTION PANELS, FBDL SERIES

Lowara supplies panels for the complete control and command of the FBDL series electric pumps, designed to cover all the most common applications. Panels for special applications can be supplied upon request. The standard configurations allow floats to be connected to the panels.

PUMP TYPE THREE-PHASE	1 PUMP		2 PUMPS	
	220-240 V	380-415 V	220-240 V	380-415 V
FBDL 62-22	on request	QDR/11	9QDRM2/11	9QDR2/15
FBDL 62-21	on request	QDR/15	on request	9QDR2/15
FBDL 64-22	on request	QDR/22	on request	9QDR2/22
FBDL 65-22	QDR/43-52/230/FG	QDR/38-52/FG	9QDR2/43-52/230/FG	9QDR2/38-52/FG
FBDL 66-21	QDR/66/230/FG	QDR/54-68/FG	9QDR2/66/230/FG	9QDR2/54-68/FG
FBDLV 40-21	on request	QDR/03	on request	9QDR2/05

FBDL_B_TQ

PUMP TYPE	1 PUMP
SINGLE-PHASE	220-240 V
FBDLM 62-22	QDRM/11
FBDLVM 40-21	on request

2 PUMPS
220-240 V
9QDRM2/11
on request

INSTALLATION ACCESSORIES - FDL SERIES

The FDL series electric pumps can be installed with different configurations. Accessories are available enabling the most suitable installation for all the most common applications.

PUMP TYPE	LOWERING SYSTEM	90° DELIVERY UNION	THREADED FLANGE FOR DELIVERY PORT	TRIPOD STAND
THREE-PHASE				
FDL 62-26	FDS DN 65/1	90° 2 1/2" BEND	2 1/2" FLANGE *	-
FDL 62-25	FDS DN 65/1	90° 2 1/2" BEND	2 1/2" FLANGE *	-
FDL 62-24	FDS DN 65/1	90° 2 1/2" BEND	2 1/2" FLANGE *	-
FDL 62-23	FDS DN 65/1	90° 2 1/2" BEND	2 1/2" FLANGE *	-
FDL 62-21	FDS DN 65/1	90° 2 1/2" BEND	2 1/2" FLANGE *	-
FDL 815-23	FDS3 DN 80	90° DN 80 BEND	-	DN 80 TRIPOD STAND *
FDL 815-22	FDS3 DN 80	90° DN 80 BEND	-	DN 80 TRIPOD STAND *
FDL 815-21	FDS3 DN 80	90° DN 80 BEND	-	DN 80 TRIPOD STAND *
FDL 81-42	FDS3 DN 80	90° DN 80 BEND	-	DN 80 TRIPOD STAND *
FDL 82-41N	FDS3 DN 80	90° DN 80 BEND	-	DN 80 TRIPOD STAND *
FDL 83-41	FDS3 DN 80	90° DN 80 BEND	-	DN 80 TRIPOD STAND *
FDL 104-42	FDS4 DN 100	90° DN 100 BEND	-	DN 100 TRIPOD STAND *
FDL 104-41	FDS4 DN 100	90° DN 100 BEND	-	DN 100 TRIPOD STAND *
FDL 106-41	FDS4 DN 100	90° DN 100 BEND	-	DN 100 TRIPOD STAND *
FDL 107-41	FDS4 DN 100	90° DN 100 BEND	-	DN 100 TRIPOD STAND *
FDL 109-42	FDS4 DN 100	90° DN 100 BEND	-	DN 100 TRIPOD STAND *
FDL 109-41	FDS4 DN 100	90° DN 100 BEND	-	DN 100 TRIPOD STAND *
FDL 152-43	FDS6 DN 150	90° DN 100 BEND	-	DN 150 TRIPOD STAND *
FDL 152-42	FDS6 DN 150	90° DN 100 BEND	-	DN 150 TRIPOD STAND *
FDL 152-41	FDS6 DN 150	90° DN 100 BEND	-	DN 150 TRIPOD STAND *
FDL 64-22	FDS DN 65/9	90° DN 65 BEND	-	DN 80 TRIPOD STAND *
FDL 85-22	FDS3 DN 80	90° DN 80 BEND	-	DN 80 TRIPOD STAND *
FDL 86-21	FDS3 DN 80	90° DN 80 BEND	-	DN 80 TRIPOD STAND *
FDL 118-24	FDS4 DN 100	90° DN 100 BEND	-	DN 100 TRIPOD STAND *
FDL 118-23	FDS4 DN 100	90° DN 100 BEND	-	DN 100 TRIPOD STAND *
FDL 118-22	FDS4 DN 100	90° DN 100 BEND	-	DN 100 TRIPOD STAND *
FDL 118-21	FDS4 DN 100	90° DN 100 BEND	-	DN 100 TRIPOD STAND *
FDL 107-42	FDS4 DN 100	90° DN 100 BEND	-	DN 100 TRIPOD STAND *
FDL 101-41	FDS4 DN 100	90° DN 100 BEND	-	DN 100 TRIPOD STAND *
FDL 153-43	FDS6 DN 150	90° DN 150 BEND	-	DN 150 TRIPOD STAND *
FDL 153-43/1	FDS6 DN 150	90° DN 150 BEND	-	DN 150 TRIPOD STAND *
FDL 153-41/1	FDS6 DN 150	90° DN 150 BEND	-	DN 150 TRIPOD STAND *
FDL 153-42	FDS6 DN 150	90° DN 150 BEND	-	DN 150 TRIPOD STAND *
FDL 153-41	FDS6 DN 150	90° DN 150 BEND	-	DN 150 TRIPOD STAND *
FDL 154-43	FDS6 DN 150	90° DN 150 BEND	-	DN 150 TRIPOD STAND *
FDL 154-42	FDS6 DN 150	90° DN 150 BEND	-	DN 150 TRIPOD STAND *
FDL 154-41	FDS6 DN 150	90° DN 150 BEND	-	DN 150 TRIPOD STAND *
FDL 102-61	FDS4 DN 100	90° DN 100 BEND	-	DN 100 TRIPOD STAND *
FDL 158-61	FDS6 DN 150	90° DN 150 BEND	-	DN 150 TRIPOD STAND *
FDL 151-62	FDS6 DN 150	90° DN 150 BEND	-	DN 150 TRIPOD STAND *
FDL 151-61	FDS6 DN 150	90° DN 150 BEND	-	DN 150 TRIPOD STAND *
FDL 201-63	FDS8 DN 200	on request	-	DN 200 TRIPOD STAND *
FDL 201-62	FDS8 DN 200	on request	-	DN 200 TRIPOD STAND *
FDL 201-61	FDS8 DN 200	on request	-	DN 200 TRIPOD STAND *
FDL 252-62	FDS10 DN 250-300	on request	-	DN 250 TRIPOD STAND *
FDL 253-64	FDS10 DN 250-300	on request	-	DN 250 TRIPOD STAND *
FDL 252-61	FDS10 DN 250-300	on request	-	DN 250 TRIPOD STAND *
FDL 253-63	FDS10 DN 250-300	on request	-	DN 250 TRIPOD STAND *
FDL 253-62	FDS10 DN 250-300	on request	-	DN 250 TRIPOD STAND *
FDL 253-61	FDS10 DN 250-300	on request	-	DN 250 TRIPOD STAND *

* standard

FDL_C_TA

INSTALLATION ACCESSORIES - FDLV SERIES

The FDLV series electric pumps can be installed with different configurations. Accessories are available enabling the most suitable installation for all the most common applications.

PUMP TYPE THREE-PHASE	LOWERING SYSTEM	90° DELIVERY UNION	THREADED FLANGE FOR DELIVERY PORT	TRIPOD STAND
FDLV 62-22	FDS DN 65	90° DN 65 BEND	-	DN 80 TRIPOD STAND *
FDLV 62-21	FDS DN 65	90° DN 65 BEND	-	DN 80 TRIPOD STAND *
FDLV 84-22	FDS3 DN 80	90° DN 80 BEND	-	DN 80 TRIPOD STAND *
FDLV 85-21	FDS3 DN 80	90° DN 80 BEND	-	DN 80 TRIPOD STAND *
FDLV 815-24	FDS3 DN 80	90° DN 80 BEND	-	DN 80 TRIPOD STAND *
FDLV 815-23	FDS3 DN 80	90° DN 80 BEND	-	DN 80 TRIPOD STAND *
FDLV 815-22	FDS3 DN 80	90° DN 80 BEND	-	DN 80 TRIPOD STAND *
FDLV 815-21	FDS3 DN 80	90° DN 80 BEND	-	DN 80 TRIPOD STAND *
FDLV 62-45	FDS DN 65/1	90° 2 1/2" BEND	2 1/2" FLANGE *	-
FDLV 62-44	FDS DN 65/1	90° 2 1/2" BEND	2 1/2" FLANGE *	-
FDLV 62-43	FDS DN 65/1	90° 2 1/2" BEND	2 1/2" FLANGE *	-
FDLV 61-42	FDS DN 65	90° DN 65 BEND	-	DN 80 TRIPOD STAND *
FDLV 61-41	FDS DN 65	90° DN 65 BEND	-	DN 80 TRIPOD STAND *
FDLV 82-42N	FDS3 DN 80	90° DN 80 BEND	-	DN 80 TRIPOD STAND *
FDLV 82-41N	FDS3 DN 80	90° DN 80 BEND	-	DN 80 TRIPOD STAND *
FDLV 83-42N	FDS3 DN 80	90° DN 80 BEND	-	DN 80 TRIPOD STAND *
FDLV 83-41N	FDS3 DN 80	90° DN 80 BEND	-	DN 80 TRIPOD STAND *
FDLV 104-41	FDS4 DN 100	90° DN 100 BEND	-	DN 100 TRIPOD STAND *
FDLV 106-42	FDS4 DN 100	90° DN 100 BEND	-	DN 100 TRIPOD STAND *
FDLV 106-41	FDS4 DN 100	90° DN 100 BEND	-	DN 100 TRIPOD STAND *
FDLV 152-44	FDS6 DN 150	90° DN 150 BEND	-	DN 150 TRIPOD STAND *
FDLV 152-43	FDS6 DN 150	90° DN 150 BEND	-	DN 150 TRIPOD STAND *
FDLV 152-42	FDS6 DN 150	90° DN 150 BEND	-	DN 150 TRIPOD STAND *
FDLV 153-41	FDS6 DN 150	90° DN 150 BEND	-	DN 150 TRIPOD STAND *
FDLV 158-64	FDS6 DN 150	90° DN 150 BEND	-	DN 150 TRIPOD STAND *
FDLV 158-63	FDS6 DN 150	90° DN 150 BEND	-	DN 150 TRIPOD STAND *
FDLV 151-62	FDS6 DN 150	90° DN 150 BEND	-	DN 150 TRIPOD STAND *
FDLV 151-61	FDS6 DN 150	90° DN 150 BEND	-	DN 150 TRIPOD STAND *

* standard

FDLV_C_TA

INSTALLATION ACCESSORIES - FDLT SERIES

The FDLT series electric pumps can be installed with different configurations. Accessories are available enabling the most suitable installation for all the most common applications.

PUMP TYPE	LOWERING SYSTEM	90° DELIVERY UNION	THREADED FLANGE FOR DELIVERY PORT	TRIPOD STAND
THREE-PHASE				
FDLT 41-23	FDS2T DN 50	90° 2" BEND	1 1/2" FLANGE - FDLT *	-
FDLT 41-22	FDS2T DN 50	90° 2" BEND	1 1/2" FLANGE - FDLT *	-
FDLT 41-21	FDS2T DN 50	90° 2" BEND	1 1/2" FLANGE - FDLT *	-
FDLT 42-22	FDS2T DN 50	90° 2" BEND	1 1/2" FLANGE - FDLT *	-
FDLT 42-21	FDS2T DN 50	90° 2" BEND	1 1/2" FLANGE - FDLT *	-
FDLT 43-22	FDS2T DN 50	90° 2" BEND	1 1/2" FLANGE - FDLT *	-
FDLT 43-21	FDS2T DN 50	90° 2" BEND	1 1/2" FLANGE - FDLT *	-
FDLT 44-22	FDS2T DN 50	90° 2" BEND	1 1/2" FLANGE - FDLT *	-
FDLT 44-21	FDS2T DN 50	90° 2" BEND	1 1/2" FLANGE - FDLT *	-
FDLT 45-21	FDS2T DN 50	90° 2" BEND	1 1/2" FLANGE - FDLT *	-

PUMP TYPE	LOWERING SYSTEM	90° DELIVERY UNION	THREADED FLANGE FOR DELIVERY PORT	TRIPOD STAND
SINGLE-PHASE				
FDLMT 41-23	FDS2T DN 50	90° 2" BEND	1 1/2" FLANGE - FDLT *	-
FDLMT 41-22	FDS2T DN 50	90° 2" BEND	1 1/2" FLANGE - FDLT *	-
FDLMT 41-21	FDS2T DN 50	90° 2" BEND	1 1/2" FLANGE - FDLT *	-
FDLMT 42-22	FDS2T DN 50	90° 2" BEND	1 1/2" FLANGE - FDLT *	-
FDLMT 42-21	FDS2T DN 50	90° 2" BEND	1 1/2" FLANGE - FDLT *	-

* standard

FDLT_C_TA

INSTALLATION ACCESSORIES - FXDL SERIES

The FXDL series electric pumps can be installed with different configurations. Accessories are available enabling the most suitable installation for all the most common applications.

PUMP TYPE THREE-PHASE	LOWERING SYSTEM	90° DELIVERY UNION	THREADED FLANGE FOR DELIVERY PORT	TRIPOD STAND
FXDL 41-21	FXDS2T/1 DN 50	-	-	-
FXDL 53-22	FXDS2T DN 50	-	-	-
FXDL 56-23	FXDS2T DN 50	-	-	-
FXDL 56-22	FXDS2T DN 50	-	-	-
FXDL 56-21	FXDS2T DN 50	-	-	-
FXDL 62-22	XPA DN 70	on request	2" 1/2 FLANGE - FXDL *	-
FXDL 62-21	XPA DN 70	on request	2" 1/2 FLANGE - FXDL *	-
FXDL 64-22	XPA DN 70	on request	2" 1/2 FLANGE - FXDL *	-
FXDL 65-22	XPA DN 70	on request	2" 1/2 FLANGE - FXDL *	-
FXDL 66-21	XPA DN 70	on request	2" 1/2 FLANGE - FXDL *	-
FXDLV 41-21	FXDS2T/1 DN 50	-	-	-

* standard

FXDL_C_TA

INSTALLATION ACCESSORIES - FBDL SERIES

The FBDL series electric pumps can be installed with different configurations. Accessories are available enabling the most suitable installation for all the most common applications.

PUMP TYPE THREE-PHASE	LOWERING SYSTEM	90° DELIVERY UNION	THREADED FLANGE FOR DELIVERY PORT	TRIPOD STAND
FBDL 62-22	XPA DN 70	90° DN 70BEND - FBDL	2 1/2" FLANGE - FBDL *	-
FBDL 62-21	XPA DN 70	90° DN 70BEND - FBDL	2 1/2" FLANGE - FBDL *	-
FBDL 64-22	XPA DN 70	90° DN 70BEND - FBDL	2 1/2" FLANGE - FBDL *	-
FBDL 65-22	XPA DN 70	90° DN 70BEND - FBDL	2 1/2" FLANGE - FBDL *	-
FBDL 66-21	XPA DN 70	90° DN 70BEND - FBDL	2 1/2" FLANGE - FBDL *	-
FBDLV 40-21	on request	-	-	-

PUMP TYPE SINGLE-PHASE	LOWERING SYSTEM	90° DELIVERY UNION	THREADED FLANGE FOR DELIVERY PORT	TRIPOD STAND
FBDLM 62-22	XPA DN 70	90° DN 70BEND - FBDL	2 1/2" FLANGE - FBDL *	-
FBDLVM 40-21	on request	-	-	-

* standard

FBDL_C_TA

EXAMPLE OF INSTALLATION WITH LOWERING SYSTEM

Access to the electric pump for inspection or maintenance is quick and easy: to extract the pump, just lift it with a chain. The pump's stability and seal are ensured by its weight.

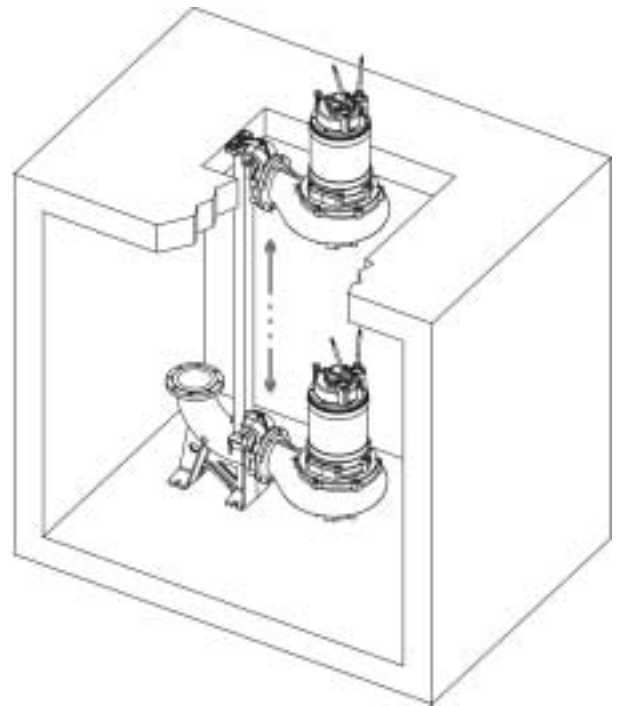
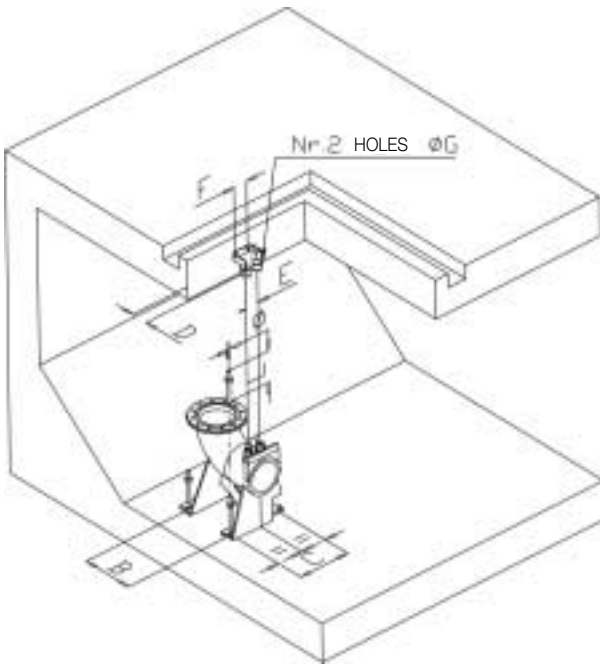

LEGEND

Reference	Description	DN 50	DN 65	DN 70 *	DN 80	DN 100	DN 150	DN 200	DN 250-300
B	Foot centre distance, side	110	180	79	250	250	300	400	500
C	Foot centre distance, front	100	140	151	160	160	200	250	500
D	Pipe support distance	86	85	86	85	85	85	85	120
E	Guide tubes centre distance	35	140	-	100	100	100	100	125
F	Support holes centre distance	52	64	-	64	64	64	64	100
G	Support hole diameter	12	12	12	12	12	12	12	19
L	Length of foot fastening hole	130	130	130	130	130	150	150	150
Ø	Hole diameter	14	14	14	14	14	18	18	18
-	Guide tube diameter	G 3/4	G 1 1/2	G 1 1/4	G 2	G 2	G 2	G 2	G 3

* single guide

SDD_A_TD

EXAMPLE OF INSTALLATION OF SINGLE-PUMP SYSTEM

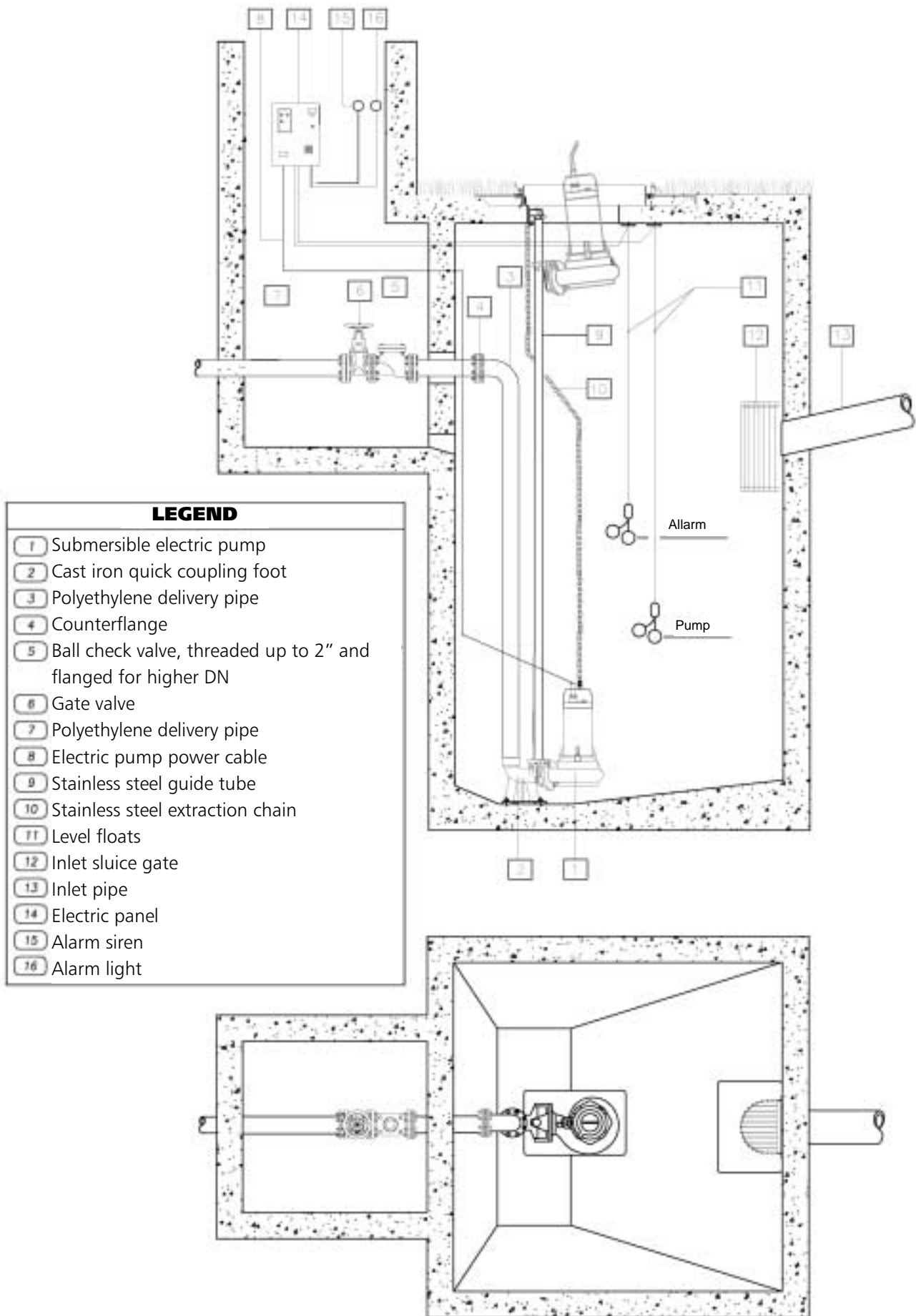

EXAMPLE OF INSTALLATION OF TWO-PUMP SYSTEM WITH THREE FLOATS

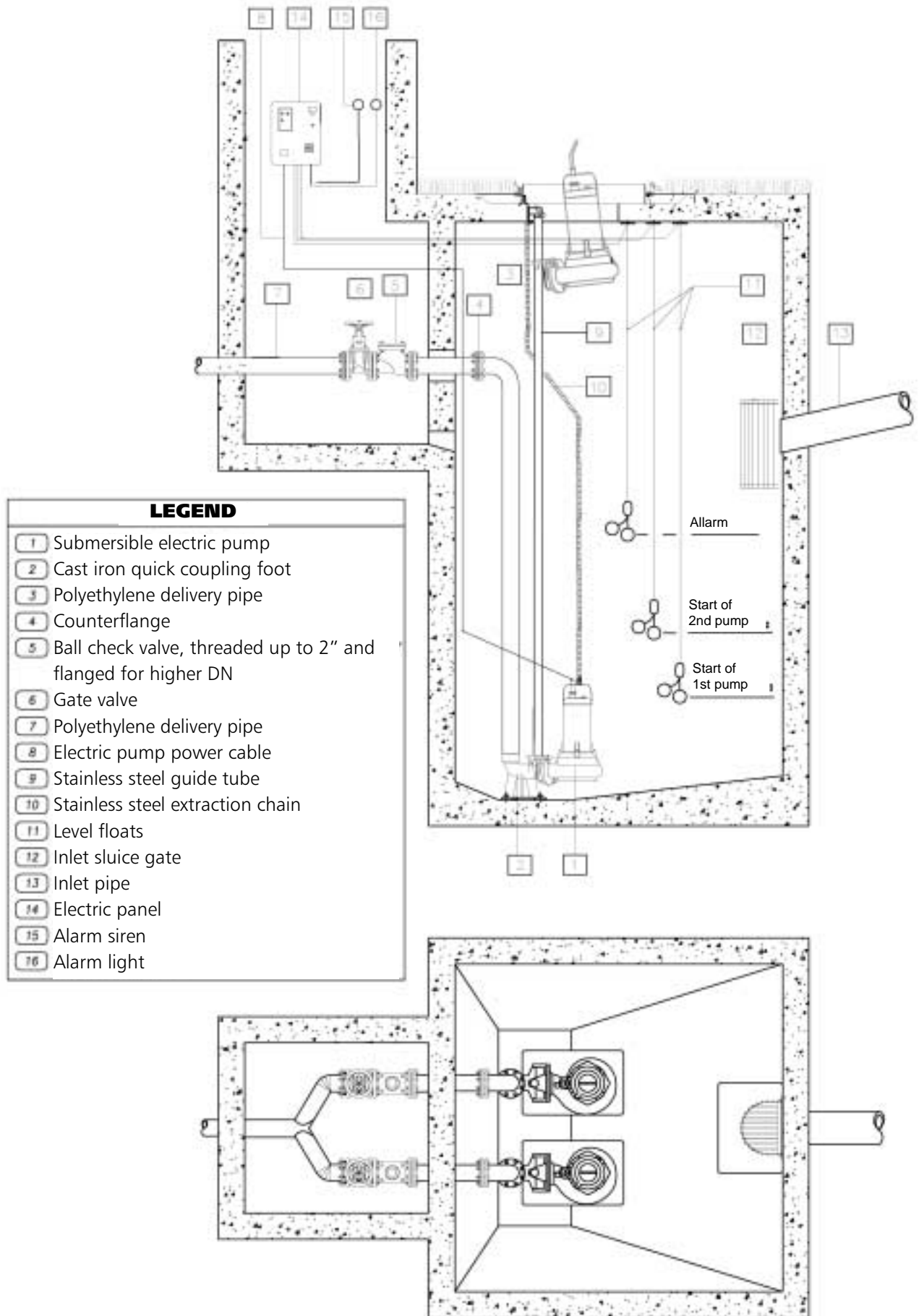

- LEGEND**
- 1 Submersible electric pump
 - 2 Cast iron quick coupling foot
 - 3 Polyethylene delivery pipe
 - 4 Counterflange
 - 5 Ball check valve, threaded up to 2" and flanged for higher DN
 - 6 Gate valve
 - 7 Polyethylene delivery pipe
 - 8 Electric pump power cable
 - 9 Stainless steel guide tube
 - 10 Stainless steel extraction chain
 - 11 Level floats
 - 12 Inlet sluice gate
 - 13 Inlet pipe
 - 14 Electric panel
 - 15 Alarm siren
 - 16 Alarm light

EXAMPLE OF INSTALLATION OF TWO-PUMP SYSTEM WITH FOUR FLOATS

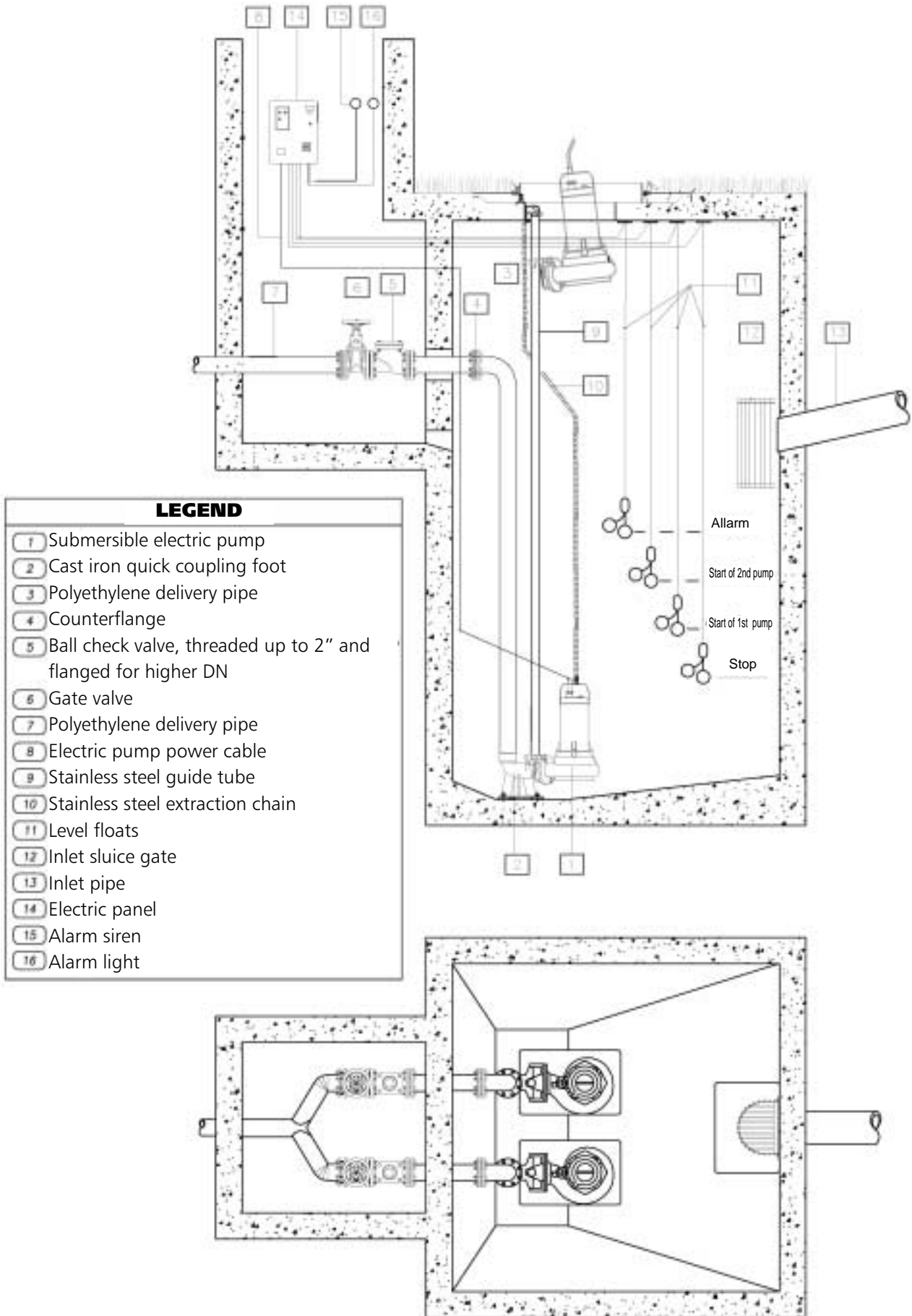

LEVEL CONTROL FLOAT

SMALL MODEL

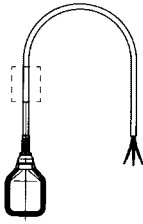

For single function (draining)
 cable length 1.5, 5, 10 m.
 Counterweight available on request for
 version with 5, 10 m cable.

KEY MODEL

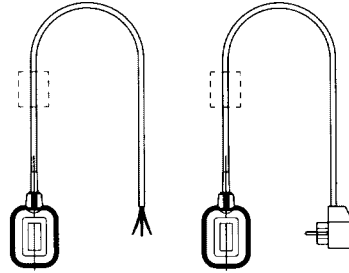

For dual function
 (draining/filling)
 cable length 1.5, 5, 10 m.
 Counterweight available on request for
 version with 5, 10 m cable.
 Version with plug and socket for
 single-phase pumps up to 1 kW.

MC MATIC MODEL

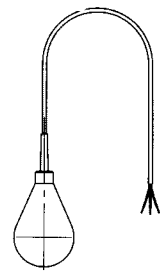

For solids-laden water (without
 mercury).
 Cable length: 15 m.

BALL CHECK VALVES FOR SOLIDS-LADEN WATER

No-clog, maximum reliability, low flow resistance.
 Maximum operating pressure: 10 bar.
 Maximum temperature: 85°C.
 Horizontal or vertical operating position.

MODEL	DIMENSIONS (mm)			WEIGHT kg
	BALL Ø	L	H	
Rp 1"1/4	48	140	80	2
Rp 1"1/2	50	140	80	4
Rp 2"	60	200	98	5,5
DN 80	95	260	163	13
DN 100	120	300	210	18
DN 150	175	400	250	37

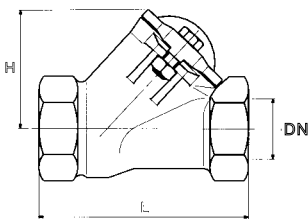

MODEL 1"1/4 - 1"1/2 - 2"

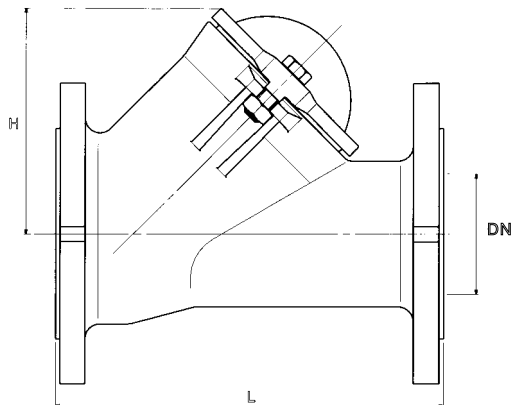

MODEL 80 - 100 - 150

FLOW RESISTANCE

TABLE OF FLOW RESISTANCE IN 100 m OF A NEW AND STRAIGHT CAST IRON PIPELINE

FLOW RATE		NOMINAL DIAMETER IN mm AND INCHES																		
m ³ /h	l/min.	15 1/2"	20 3/4"	25 1"	32 1 1/4"	40 1 1/2"	50 2"	65 2 1/2"	80 3"	100 4"	125 5"	150 6"	175 7"	200 8"	250 10"	300 12"	350 14"	400 16"		
0,6	10	V	0,94	0,53	0,34	0,21														
		hr	11,8	2,82	1	0,25														
0,9	15	V	1,42	0,8	0,51	0,31														
		hr	25,1	6,04	2,16	0,55														
1,2	20	V	1,89	1,06	0,68	0,41	0,27													
		hr	43,1	10,4	3,72	0,95	0,31													
1,5	25	V	2,36	1,33	0,85	0,52	0,33													
		hr	64,5	15,8	5,68	1,47	0,47													
1,8	30	V	2,83	1,59	1,02	0,62	0,4													
		hr	92	22,3	8	2,09	0,66													
2,1	35	V	3,3	1,86	1,19	0,73	0,46	0,3												
		hr	123	29,8	10,8	2,81	0,89	0,31												
2,4	40	V	3,77	2,12	1,36	0,83	0,53	0,34												
		hr	164	38,2	13,8	2,65	1,15	0,4												
3	50	V	4,72	2,65	1,7	1,04	0,66	0,42												
		hr	246	58,2	21,5	5,6	1,75	0,61												
3,6	60	V	3,18	2,04	1,24	0,8	0,51													
		hr	82	30	8	2,48	0,86													
4,2	70	V		3,72	2,38	1,45	0,93	0,59												
		hr		110	40	10,8	3,33	1,14												
4,8	80	V		4,25	2,72	1,66	1,06	0,68												
		hr		141	51,5	13,9	4,3	1,46												
5,4	90	V			3,06	1,87	1,19	0,76	0,45											
		hr			64	17,5	5,4	1,82	0,46											
6	100	V			3,4	2,07	1,33	0,85	0,5											
		hr			79	21,4	6,6	2,22	0,56											
7,5	125	V			4,25	2,59	1,66	1,06	0,63											
		hr			120	33	10	3,4	0,86											
9	150	V				3,11	1,99	1,27	0,75	0,5										
		hr				47	14,2	4,74	1,21	0,43										
10,5	175	V				3,63	2,32	1,49	0,88	0,58										
		hr				63	19	6,3	1,63	0,57										
12	200	V				4,15	2,65	1,7	1,01	0,66										
		hr				82	24,5	8,1	2,1	0,74										
15	250	V				5,18	3,32	2,12	1,26	0,83	0,53									
		hr				126	37,5	12,3	3,2	1,12	0,36									
18	300	V					3,98	2,55	1,51	1	0,64									
		hr					53	17,3	4,5	1,58	0,51									
24	400	V				5,31	3,4	2,01	1,33	0,85										
		hr				92	29,5	7,8	2,7	0,89										
30	500	V				6,63	4,25	2,51	1,66	1,06	0,68									
		hr				140	44,8	12	4,13	1,36	0,48									
36	600	V					5,1	3,02	1,99	1,27	0,82									
		hr					63	16,9	5,8	1,93	0,68									
42	700	V					5,94	3,52	2,32	1,49	0,95									
		hr					84	22,6	7,8	2,6	0,9									
48	800	V					6,79	4,02	2,65	1,70	1,09	0,75								
		hr					108	29	10	3,35	1,16	0,43								
54	900	V					7,64	4,52	2,99	1,91	1,22	0,85								
		hr					134	36	12,5	4,2	1,45	0,54								
60	1000	V						5,03	3,32	2,12	1,36	0,94								
		hr						44,5	15,2	5,14	1,76	0,66								
75	1250	V						6,28	4,15	2,65	1,70	1,18	0,87							
		hr						68	23	7,9	2,68	1	0,48							
90	1500	V						7,54	4,98	3,18	2,04	1,42	1,04							
		hr						96	32,6	11,2	3,77	1,42	0,68							
105	1750	V						8,79	5,81	3,72	2,38	1,65	1,21	0,93						
		hr						129	43,5	15	5,04	1,9	0,91	0,45						
120	2000	V							6,63	4,25	2,72	1,89	1,39	1,06	0,68					
		hr							56	19,4	6,5	2,43	1,18	0,58	0,16					
150	2500	V							8,29	5,31	3,40	2,36	1,73	1,33	0,85					
		hr							85	30	9,8	3,75	1,79	0,89	0,25					
180	3000	V							9,95	6,37	4,08	2,83	2,08	1,59	1,02	0,71				
		hr							120	42	13,8	5,3	2,53	1,25	0,35	0,15				
300	5000	V							10,62	6,79	4,72	3,47	2,65	1,70	1,18	0,87	0,66			
		hr							124,9	41,3	16,74	7,81	4,03	1,34	0,54	0,25	0,13			
600	10000	V							13,59	9,44	6,93	5,31	3,4	2,36	1,73	1,33	0,85			
		hr							161	65	30,2	15,6	5,16	2,09	0,97	0,5				
1200	20000	V												6,79	4,72	3,47	2,65			
		hr												20,1	8,13	3,8	1,95			
1800	30000	V															7,7	5,2	4,0	
		hr															18,07	8,39	4,32	
3000	50000	V															11,8	8,67	6,63	
		hr															49,5	23	11,8	
4500	75000	V															17,7	13	9,9	
		hr															110,5	51,3	26,4	
6000	100000	V															17,33	13,27		
		hr															90,6	46,6		

THE FLOW RESISTANCE MUST BE MULTIPLIED BY:

- 0.8 for stainless steel pipes
- 1.25 for slightly rusted steel pipes
- 1.7 for pipes with deposits that reduce the flow section
- 0.7 for aluminium pipes
- 1.3 for fibre-cement pipes

Hr = FLOW RESISTANCE (m/100 m OF PIPELINE)
V = WATER SPEED (m/sec)

FLOW RESISTANCE
TABLE OF FLOW RESISTANCE IN BENDS, VALVES AND GATES IN cm OF COLUMN OF WATER

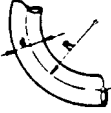
WATER SPEED m/sec	SHARP BENDS 					SMOOTH BENDS 					STANDARD GATE VALVES	FOOT VALVES	CHECK VALVES
	a = 30°	a = 40°	a = 60°	a = 80°	a = 90°	$\frac{d}{R} = 0,4$	$\frac{d}{R} = 0,6$	$\frac{d}{R} = 0,8$	$\frac{d}{R} = 1$	$\frac{d}{R} = 1,5$			
0,10	0,03	0,04	0,05	0,07	0,08	0,007	0,008	0,01	0,0155	0,027	0,030	30	30
0,15	0,06	0,07	0,10	0,14	0,17	0,016	0,019	0,024	0,033	0,06	0,033	31	31
0,2	0,11	0,13	0,18	0,26	0,31	0,028	0,033	0,04	0,058	0,11	0,058	31	31
0,25	0,17	0,21	0,28	0,4	0,48	0,044	0,052	0,063	0,091	0,17	0,090	31	31
0,3	0,25	0,30	0,41	0,6	0,7	0,063	0,074	0,09	0,13	0,25	0,13	31	31
0,35	0,33	0,40	0,54	0,8	0,93	0,085	0,10	0,12	0,18	0,33	0,18	31	31
0,4	0,43	0,52	0,71	1,0	1,2	0,11	0,13	0,16	0,23	0,43	0,23	32	31
0,5	0,67	0,81	1,1	1,6	1,9	0,18	0,21	0,26	0,37	0,67	0,37	33	32
0,6	0,97	1,2	1,6	2,3	2,8	0,25	0,29	0,36	0,52	0,97	0,52	34	32
0,7	1,35	1,65	2,2	3,2	3,9	0,34	0,40	0,48	0,70	1,35	0,70	35	32
0,8	1,7	2,1	2,8	4,0	4,8	0,45	0,53	0,64	0,93	1,7	0,95	36	33
0,9	2,2	2,7	3,6	5,2	6,2	0,57	0,67	0,82	1,18	2,2	1,20	37	34
1,0	2,7	3,3	4,5	6,4	7,6	0,7	0,82	1,0	1,45	2,7	1,45	38	35
1,5	6,0	7,3	10	14	17	1,6	1,9	2,3	3,3	6	3,3	47	40
2,0	11	14	18	26	31	2,8	3,3	4,0	5,8	11	5,8	61	48
2,5	17	21	28	40	48	4,4	5,2	6,3	9,1	17	9,1	78	58
3,0	25	30	41	60	70	6,3	7,4	9	13	25	13	100	71
3,5	33	40	55	78	93	8,5	10	12	18	33	18	123	85
4,0	43	52	70	100	120	11	13	16	23	42	23	150	100
4,5	55	67	90	130	160	14	21	26	37	55	37	190	120
5,0	67	82	110	160	190	18	29	36	52	67	52	220	140

- 1) Flow resistance in bends is due to the contraction of the liquid threads resulting from the change of direction: the development of the bends must therefore be included in the length of the pipeline.
- 2) Flow resistance in valves and gates was determined on the basis of practical tests.