

ABS light drainage pump IP 900

The IP 900 is a high-grade stainless steel pump for aggressive media in accordance with EN 12050-2. Vortex hydraulics with 30 mm free passage make it particularly suitable for the pumping of fluids containing gaseous or abrasive particles.



Applications

- Pumping of aggressive media.
- Pumping of clear and rain water.
- For blockage-free pumping of liquids which have a high proportion of solid or fibrous matter present.
- Dewatering of buildings and sites.
- Emptying or filling of containers.
- Suitable for use in septic tanks, for the emptying of flooded cellars and for drainage.

The combination of high-grade stainless steel 1.4401 (AISI 316), static seals of Viton, and mechanical seal of silicon carbide; plus other features, makes this the ideal pump for chemically contaminated wastewater, industrial effluent, and for use in agriculture.

Construction

- Discharge outlet with G 2" internal thread.
- Watertight, fully flood-proof, high-grade stainless steel motor housing.
- 2-pole motor is dynamically balanced with high-grade stainless steel shaft 1.4401 (AISI 316).
- Thermal sensors in the stator switch off the pump in the event of overheating and automatically switch it back on after cooling down.
- Sealing on the motor side is by means of a silicon carbide mechanical seal.
- The maximum allowable medium temperature is 40 °C; or up to 60 °C for intermittent usage (max 5 minutes).
- Hydraulic section with vortex impeller (free solids passage 30 mm).
- A version with ABS float switch KS is available for automatic operation.



Features

- Specially designed for aggressive media using high-grade stainless steel (AISI 316), Viton seals and PVC cable.
- Choice of free-standing or pedestal mounting for easy installation.
- Vortex hydraulics with 30 mm free passage for blockage-free pumping.
- Available in manual or automatic versions.

Materials

Description	Material
Motor Housing/Volute	Stainless steel 1.4401 (AISI 316)
Rotor Shaft	Stainless steel 1.4401 (AISI 316)
Impeller	Stainless steel 1.4401 (AISI 316)
Mechanical Seal	Silicon carbide
Other seals	Viton
Fasteners	Stainless steel 1.4401 (AISI 316)
Motor Cable	PVC
Float Cable	PVC
Float Housing	Polypropylene

The suitability of the materials in the pump, for the particular application, is the responsibility of the user.

Technical Data

IP 900	D	W
Discharge connection internal thread	G 2"	G 2"
Solids size (mm)	30	30
Motor power * (kW)	P ₁ = 1.4 P ₂ = 1.1	P ₁ = 1.5 P ₂ = 1.1
Speed (r/min)	2900	2900
Rated voltage (V)	400 3~	220-240 1~
Rated current (A)	2.4	6.6
Cable type (H05V V-F)	4G1.0	3G1.0
Cable length (m)	10	10
Weight (kg)	12	12

*P₁ = Power taken from mains. P₂ = Power at motor shaft

Performance Curve

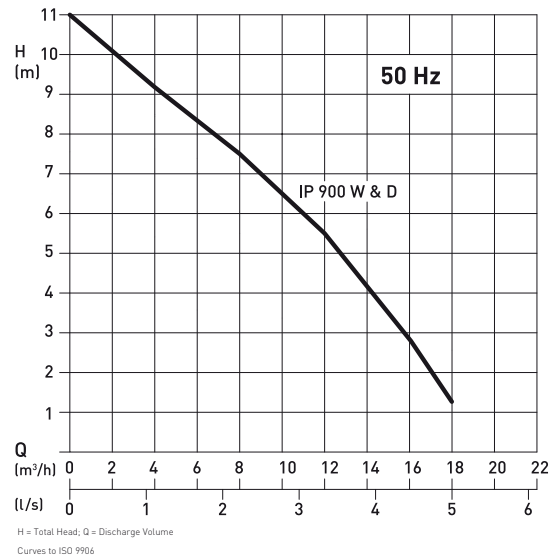

Accessories

Description	Part no.	
Pedestal G 2" cast iron EN-GJL-250; without bend	62320560	
Pedestal G 2" stainless steel; without bend	62320690	
Guide Tube 1¼" (steel galv.)	1 m	31380007
	2 m	31380008
	3 m	31380009
	4 m	31380010
	5 m	31380011
Non-return Ball Valve G 2" cast iron EN-GJL-250	61400527	
Gate Valve G 2" (EN-GJL-250) including hand wheel, 1 set of bolts and 1 gasket	14040007	
Control Unit		
BPC control cabinet (single phase)	62165097	
BPC control cabinet (three phase)	62165100	

Dimensions (mm)

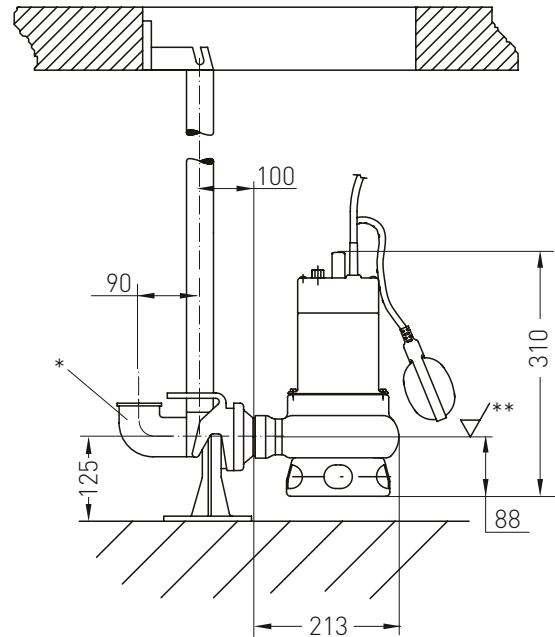

* Elbow supplied by customer
** Lowest switch-off level
(lowest switch-on level is at least 100 mm higher)