

ABS lifting station Sanimat 2002

Flood-proof, double lifting station, for automatic sewage pumping from areas below the backwash level in accordance with EN 12050-1. Ideal for effective dewatering of domestic residences, large buildings or commercial developments. Suitable for new installations or for renovation of old buildings.



Features

- Plug-in unit with CEE plug and phase sequence changeover facility.
- Easily transported and fitted. Compact dimensions allow passage through a standard door opening.
- Dynamic pressure level sensor on the tank, with separate sensors for inflow level and high water alarm.
- Trouble-free maintenance thanks to simple removal of the motor housing.
- Vortex impeller with large free passage for reliable pumping of both faecal and faecal-free sewage.
- Option of 2- or 4-pole motors.
- Direct toilet connection possible in the case of wall-mounted WC units.
- One variable inlet (DN 150) with 90° elbow, two horizontal (DN 150), and five vertical (2 x DN 100/150, 2 x DN 70, 1 x DN 40). One DN 70 port is needed as a vent line. DN 40 port is suitable for the connection of a hand membrane pump.
- Discharge flange DN 80, plus flanged socket with 4" sleeve and clips (for discharge pipe DN80/100).
- Sloping container floor prevents deposits.
- Integrated valve system consisting of two ball-type, non-return valves.
- Built-in mains alarm (visual and acoustic), can be converted to mains-independent by inserting battery.
- Maximum allowable medium temperature 40 °C; or up to 60 °C intermittent (max. 5 minutes).

Installation

Attention to the backwash level is of vital importance for effective dewatering. All outflow points located below the backwash level must be protected against back flow according to standard EN 12056.

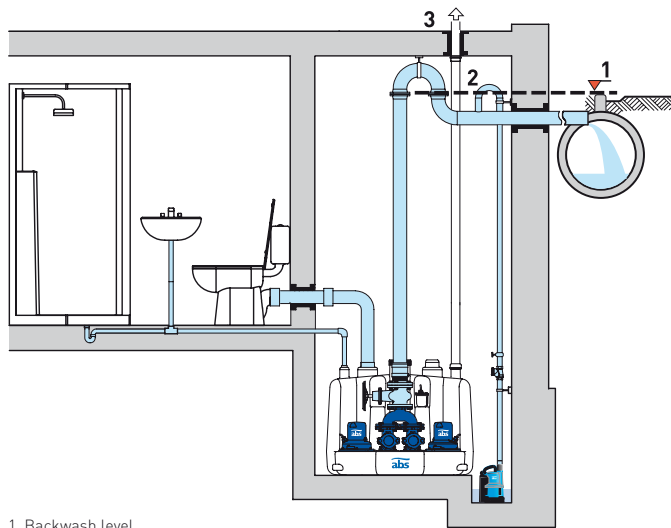

1. Backwash level
2. Backwash loop with base below the backwash level
3. External ventilation pipe

Materials

Description	Material
Tank	Polyethylene
Motor Housing	Cast iron EN-GJL-250
Rotor Shaft	Stainless steel 1.4021 (AISI 420)
Volute	Polyethylene
Impeller	Cast iron EN-GJL-250

Tank

Synthetic, corrosion-resistant, gas- and odour-tight tank in accordance with EN 12050-1. Supplied as standard with pumps, junction piece with integral non-return valve system and cleaning openings, 4" sleeve and flange, automatic level control and control panel. Capacity: 320 litres

Motor

Water pressure sealed, squirrel cage 2- and 4-pole induction motor, with triple shaft seals and oil chamber. Electronic monitoring of stator temperature and overcurrent. Insulation: class F for 155 °C, protection type IP 68

Performance Curves

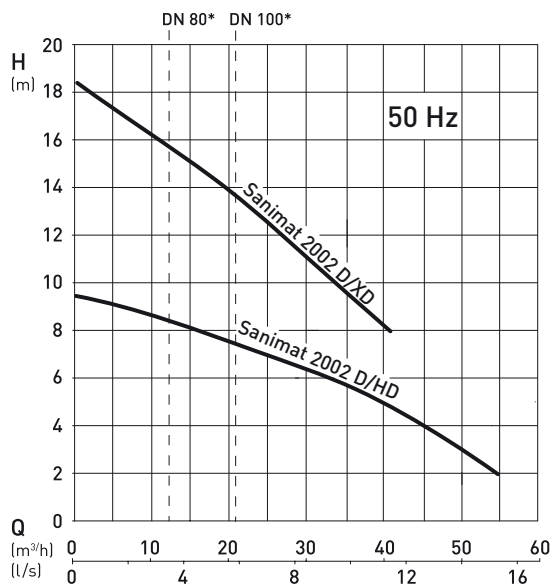

* Minimum flow rate Q for discharge pipe.
H = Total Head; Q = Discharge Volume; Curves to ISO 9906

Technical Data

Sanimat	2002 D/HD	2002 D/XD
Discharge connection	Sleeve 4" DN 100	Sleeve 4" DN 100
Motor power (kW)*	P ₁ = 2.88 P ₂ = 2.20	P ₁ = 3.70 P ₂ = 3.00
Speed (r/min)	1450	2900
Rated voltage (V)	400 3~	400 3~
Rated current (A)	5.2	6.2
Cable length (m)**	4 + 1.5	4 + 1.5
Weight (kg)***	132	132

* P₁ = Power taken from mains; P₂ = Power at motor shaft
 ** Tank to control unit 4 m, control unit mains 1.5 m
 *** Additional weight with hand membrane pump = 13 kg

Tank Dimensions (mm)

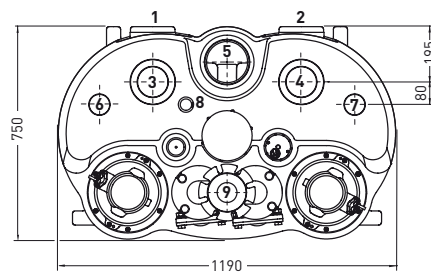
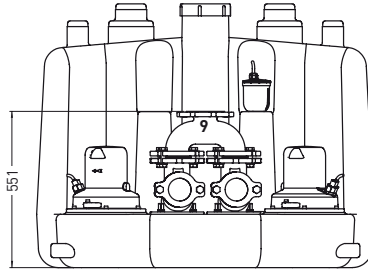
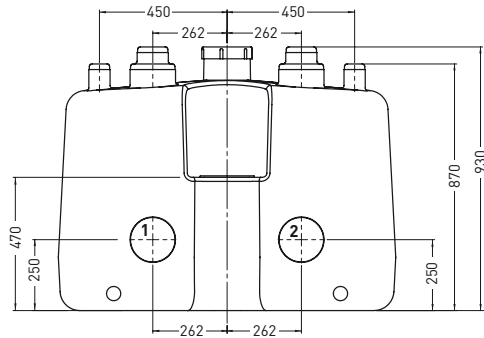

Inlet Diameters

Ø	(mm)
DN 70	+0.2 ø75 -1.0
DN 100	+0.3 ø110 -1.0
DN 150	+0.4 ø160 -1.5

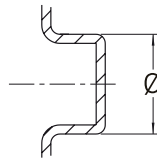

Connections

1. Inflow DN 150
2. Inflow DN 150
3. Inflow DN 100/150
4. Inflow DN 100/150
5. Inflow DN 150 (variable with 90° elbow)
6. Vent/Inflow DN 70
7. Vent/Inflow DN 70
8. Inflow/Hand membrane pump DN 40
9. Discharge flange DN 80

Note:

Rooms for sewage lifting stations must be large enough that a working area of at least 60 cm width or height is available around all parts which have to be operated or maintained. A pump sump should be provided for dewatering of the room itself.

Accessories

	Description	Size	Part no.
Discharge side	Hand Membrane Pump with built-in, non-return valve for separate wall fixing	G 1½"	14990028
	Shut-off Valve (EN-GJL-250) including one set of bolts and one flat gasket - flange PN16	DN 80	61420500
	Flanged Spigot Kit including clamps and flexible connector (1 x DN 80/4" supplied as standard)	DN 80/4" DN 80/3"	62540032 61185025
Inflow side	PVC Double Sleeve EN, HTMM	DN 100 DN 150	13760022 13760026
	Flanged Sleeve E-KS (EN-GJL-250) transition piece DIN-flange/push-on sleeve, including one set of bolts and one flat gasket. Two sleeves needed for each valve.	DN 100 DN 150	62540025 62540026
	Shut-off Valve (EN-GJL-250) including one set of bolts and one flat gasket - flange PN16	DN 100 DN 150	61420501 61420503
	Electrical		
	NC-AKKU 9 V rechargeable battery for mains-independent alarm		12820018
	Extension Cable Kit one for each pump; consisting of pump- and level-control cables with plugs	15 m	62665302
	Mains Isolator Switch for separate wall fixing	20 A	61245045