

ABS lifting station Synconta 801

Synthetic prefabricated sump, designed as a single pumping station for the automatic pumping of wastewater and sewage from locations and areas below the backwash level in accordance with EN 12050-1. Designed as a complete wastewater sump for below-ground installation and for fitting with ABS pumps from the Piranha and AS ranges.

Features

- Installed with a plastic or concrete lid, outside the building in open ground. Synconta is suitable for installations according to EN 124; Group 1 permissible traffic tonnage 5 kN/m². Maximum permissible outside pressure 0.2 bar.
- Stainless steel discharge pipe with external thread (1¼" for DN 32 tank, 2" for DN 50). DN 32 internal thread to DN 50 plastic pipe coupling is available as an accessory.
- Synconta DN 32 for one Piranha pump.
- Synconta DN 50 for one AS pump.
- Four inflow ports (1 x DN 100, 3 x DN 150) for DIN push-on connection. One port DN 70 for venting and use as a cable duct.
- Simple pump installation and maintenance, it is not necessary to enter the sump. With self-sealing coupling system the pump seals itself automatically when lowered by guide rail into position on the pedestal.
- Pump control by automatic level control system.
- Maximum allowable temperature of medium 40 °C, short term to 60 °C (max. 5 minutes).

Materials

Description	Material
Tank	Polyethylene
AS	
Motor Housing	Cast iron EN-GJL-250
Rotor Shaft	Stainless steel 1.4021 (AISI 420)
Volute	Cast iron EN-GJL-250
Impeller/Bottom plate	Cast iron EN-GJL-250
Fasteners	Stainless steel 1.4401 (AISI 316)
Piranha	
Upper Lid *	Stainless steel 1.4301 (AISI 304)
Motor Housing	Cast iron EN-GJL-250
Rotor Shaft	Stainless steel 1.4021 (AISI 420)
Volute	Cast iron EN-GJL-250
Impeller **	Cast iron EN-GJL-250
Fasteners	Stainless steel 1.4401 (AISI 316)

* Piranha 08/09

** Polyamide for Piranha 08



Tank

Synthetic, corrosion-resistant tank in accordance with EN 12050-1. Supplied as standard with plastic lid, pedestal and installation kit including ball type non-return valve and shut-off valve. Pump and level control not included.

Capacity: 460 litres (760 with extension and riser)

Weight *: 65 kg (DN 32)

72 kg (DN 50)

* Includes installation pipework but not weight of pump

Motor

Water pressure sealed, squirrel cage 2- and 4-pole induction motor with triple shaft seals and oil chamber. Electronic monitoring of stator temperature and overcurrent.

Insulation: Class F to 155 °C

Protection type: IP 68

Pump Types

- ABS submersible wastewater pump AS. With Contrablock or vortex hydraulics for pumping clear water, wastewater and sewage with large solid particles present. Up to 60 mm solids passage.
- ABS Piranha submersible grinder pump. Shredding system hydraulics which can cut and pump wastewater containing solids through small diameter discharge lines from 1¼".

Technical Data

Pump type: Std. (no Ex)	Piranha 08 W/KS	Piranha 08 D/KS	Piranha 09 W/KS	Piranha 09 D/KS			
Pump discharge internal thread	G 1¼"	G 1¼"	G 1¼"	G 1¼"			
Hydraulics	Macerator	Macerator	Macerator	Macerator			
Solids passage (mm)	n.a. ¹⁾	n.a. ¹⁾	n.a. ¹⁾	n.a. ¹⁾			
Motor power * (kW): P ₁ P ₂	1.41 1.00	1.34 1.00	2.56 1.84	2.56 2.0			
Rated current (A)	6.41	2.71	11.6	4.64			
Rated voltage (V)	220-240 1~	400 3~	220-240 1~	400 3~			
Speed (r/min)	2900	2900	2900	2900			
Cable ** (H07RN-F)	3G 1.0	4G 1.0	3G 1.0	4G 1.0			
Pump weight (kg)	18	18	23	23			
Pump type: Std. & Ex	Piranha S12/2 W	Piranha S12/2 D	Piranha S17/2 W	Piranha S17/2 D	Piranha S21/2 D	Piranha S 26/2D	
Pump discharge internal thread	G 1¼"	G 1¼"	G 1¼"	G 1¼"	G 1¼"	G 1¼"	
Hydraulics	Macerator	Macerator	Macerator	Macerator	Macerator	Macerator	
Solids passage (mm)	n.a. ¹⁾	n.a. ¹⁾	n.a. ¹⁾	n.a. ¹⁾	n.a. ¹⁾	n.a. ¹⁾	
Motor power * (kW): P ₁ P ₂	1.77 1.20	1.69 1.20	2.36 1.65	2.31 1.70	2.79 2.10	3.43 2.60	
Rated current (A)	8.22	3.29	10.60	3.97	4.75	5.64	
Rated voltage (V)	220-240 1~	400 3~	220-240 1~	400 3~	400 3~	400 3~	
Speed (r/min)	2900	2900	2900	2900	2900	2900	
Cable ** (TLO7RN-F)	4G 1.5	4G 1.5	4G 1.5	4G 1.5	4G 1.5	4G 1.5	
Pump weight (kg)	32	32	32	32	37	40	
Pump type: Std. & Ex	AS 0530 S12/2 W	AS 0530 S12/2 D	AS 0530 S17/2 D	AS 0530 S26/2 D	AS 0630 S10/4 W	AS 0630 S13/4 D	AS 0630 S22/4 D
Pump discharge internal thread / flange	G 2"	G 2"	G 2"	G 2" /	DN 65	DN 65	DN 65
Hydraulics	Vortex	Vortex	Vortex	Vortex	Vortex	Vortex	Vortex
Solids passage (mm)	40	40	40	40	60	60	60
Motor power * (kW): P ₁ P ₂	1.77 1.20	1.69 1.20	2.31 1.70	3.43 2.60	1.69 1.00	1.93 1.30	2.88 2.20
Rated current (A)	8.22	3.29	3.97	5.64	7.49	3.60	5.15
Rated voltage (V)	220-240 1~	400 3~	400 3~	400 3~	220-240 1~	400 3~	400 3~
Speed (r/min)	2900	2900	2900	2900	1450	1450	1450
Cable ** (TLO7RN-F)	4G 1.5	4G 1.5	4G 1.5	4G 1.5	4G 1.5	4G 1.5	4G 1.5
Pump weight (kg)	34	34	34	40	37	37	42
Pump type: Std. & Ex	AS 0631 S12/2 W	AS 0631 S12/2 D	AS 0631 S17/2 W	AS 0631 S17/2 D	AS 0631 S30/2 D	AS 0641 S30/2 D	
Pump discharge flange	DN 65	DN 65	DN 65	DN 65	DN 65	DN 65	
Hydraulics	Vortex	Vortex	Vortex	Vortex	Vortex	Contrablock	
Solids passage (mm)	40	40	40	40	40	45	
Motor power * (kW): P ₁ P ₂	1.77 1.20	1.69 1.20	2.36 1.65	2.31 1.70	3.74 3.00	3.74 3.00	
Rated current (A)	8.22	3.29	10.60	3.97	6.23	6.23	
Rated voltage (V)	220-240 1~	400 3~	220-240 1~	400 3~	400 3~	400 3~	
Speed (r/min)	2900	2900	2900	2900	2900	2900	
Cable ** (TLO7RN-F)	4G 1.5	4G 1.5	4G 1.5	4G 1.5	4G 1.5	4G 1.5	
Pump weight (kg)	38	38	38	38	46	42	

¹⁾ Piranha shredding system; * P₁ = Power at mains, P₂ = Power at motor shaft; ** Special rubber compound, free-end cable.
Single phase versions require a start-and-run capacitor when operated without control panel.

When fitting AS 0530 a 2-inch threaded nipple adaptor is required and must be supplied by the customer.

Technical Data

Pump type: Std. & Ex	AS 0830 S10/4 W	AS 0830 S13/4 D	AS 0830 S22/4 D	AS 0840 S12/2 W	AS 0840 S12/2 D	AS 0840 S17/2 D	AS 0840 S26/2 D
Pump discharge flange	DN 80	DN 80	DN 80	DN 80	DN 80	DN 80	DN 80
Hydraulics	Vortex	Vortex	Vortex	Contrablock	Contrablock	Contrablock	Contrablock
Solids passage (mm)	60	60	60	30	30	30	30
Motor power * (kW): P ₁	1.69	1.93	2.88	1.77	1.69	2.31	3.43
P ₂	1.00	1.30	2.20	1.20	1.20	1.70	2.60
Rated current (A)	7.49	3.60	5.15	8.22	3.29	3.97	5.64
Rated voltage (V)	220-240 1~	400 3~	400 3~	220-240 1~	400 3~	400 3~	400 3~
Speed (r/min)	1450	1450	1450	2900	2900	2900	2900
Cable ** (TLO7RN-F)	4G 1.5	4G 1.5	4G 1.5	4G 1.5	4G 1.5	4G 1.5	4G 1.5
Pump weight (kg)	40	40	42	35	35	35	40

* P₁ = Power at mains; P₂ = Power at motor shaft; ** Special rubber compound, free-end cable.
Single phase versions require a start-and-run capacitor when operated without control panel.

Performance Curves 50 Hz

Piranha 08-S26

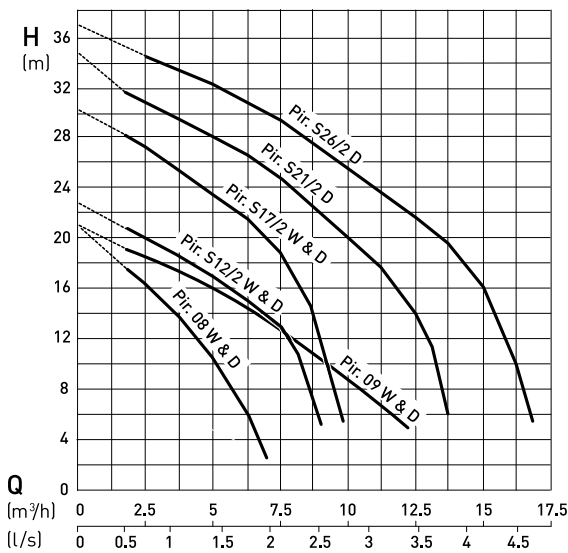

AS 0530, 0630 and 0830

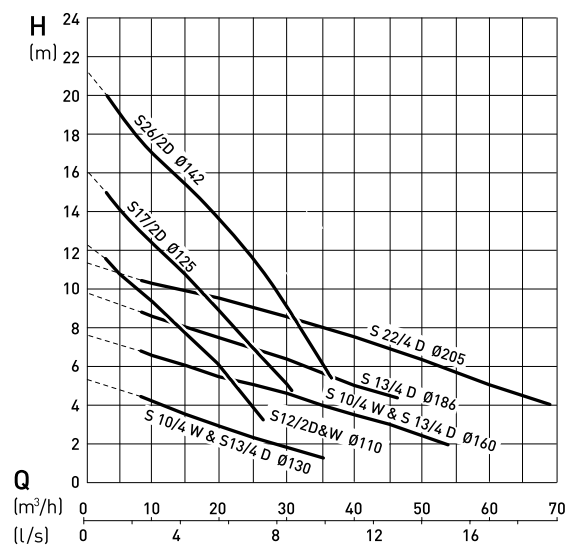

AS 0631 and 0641

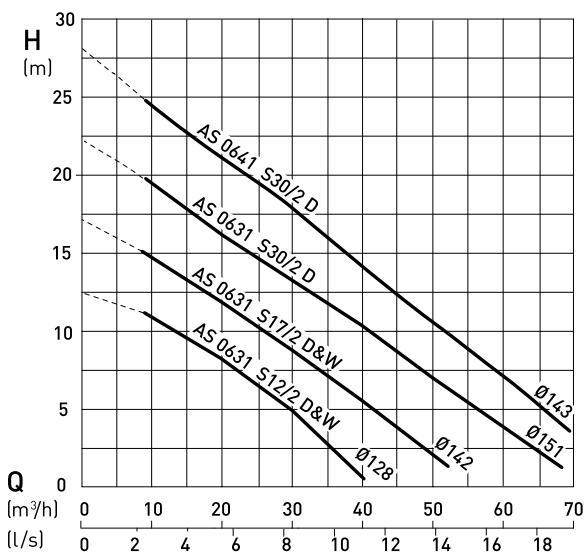

AS 0840

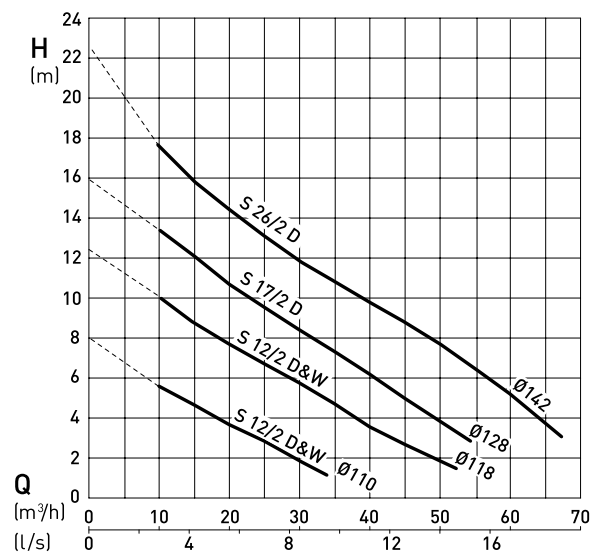

H = Total Head Q = Discharge Volume. Curves to ISO 9906 (60 Hz available on request)

Installation

Attention to the backwash level is of vital importance for effective dewatering. All outflow points located below the backwash level must be protected against back flow according to standard EN 12056.

1. Ventilation pipe to be brought above roof level
2. ABS control panel
3. Concrete lid on cast iron frame (not suitable for vehicular traffic)
4. DN 50 discharge pipe
5. Guide rail
6. Shut-off valve
7. DN 32 to DN 50 coupling
8. DN 70 connection port for cable duct and vent pipe
9. DN 100/150 inlet
10. KS float switch level control
11. ABS submersible pump
12. Ball type non-return valve

* Backwash level

** Backwash loop with base above the backwash level.

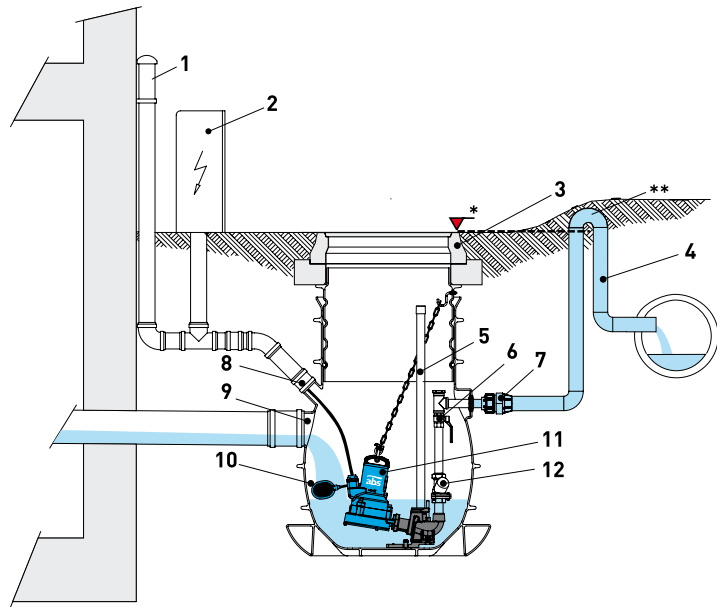

Dimensions (mm)

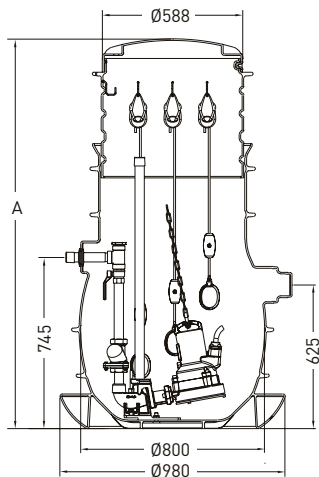

Synconta 801 with plastic lid

A = min 1420

max 1645 with riser, 2245 with riser and extension kit

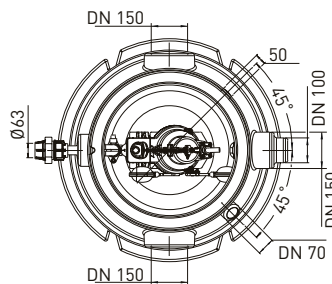

Inlet Diameters

Ø	[mm]
DN 70	+0.2 ø75 -1.0
DN 100	+0.3 ø110 -1.0
DN 150	+0.4 ø160 -1.5

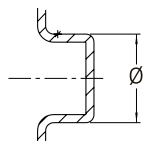

Accessories

Description	Part No.
Sump Cover - cast iron for frame with concrete filling [Class A]	14995000
Height Adjustment Ring - concrete, 80 mm height	44505000
Coupling Unit - DN 32 internal thread to DN 50 plastic pipe	13740039
Level Sensor Kit - pressure pipe	62665180
Float Kit - KS with 10 m cable	62665181
Extension Kit - 600 mm	62665182
Vacuum Breaker - for DN 32 tank	61180521
Control Unit - for internal erection with option of float switch or electropneumatic level control system. Control units for external erection also available.	